

PORCELANOSA

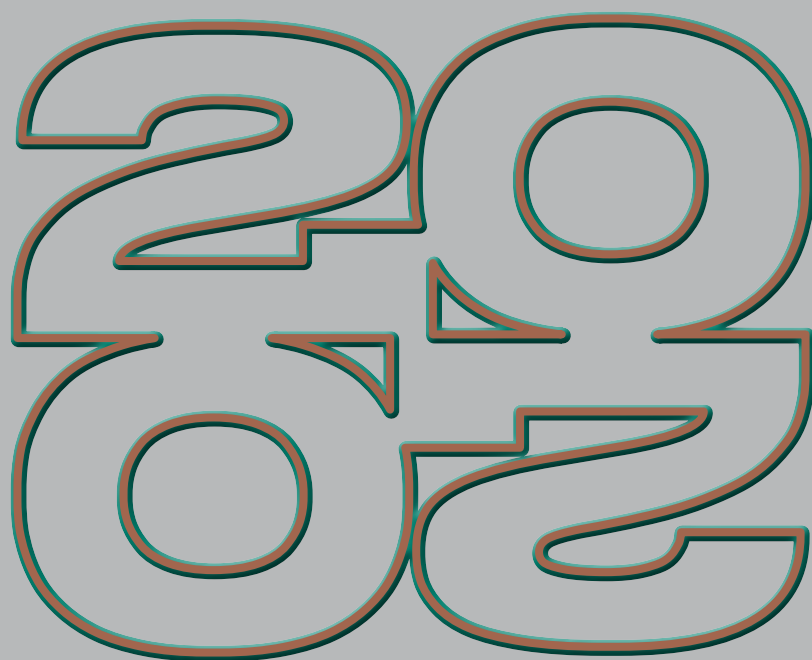

**CERAMIC BOOK**

# PORCELANOSA



BY PROMOTING  
THE PRICE OF WATER  
MANAGEMENT AND PROTECTION  
IN CHINA, THE WORLD LEADER  
IN CERAMIC TILE MANUFACTURING

PORCELANOSA Grupo







## NUESTRAS PREMISAS

### UNA CALIDAD ABSOLUTA, RED COMERCIAL PROPIA Y NUESTRA INFRAESTRUCTURA.

En PORCELANOSA basamos el éxito de los productos en tres premisas:

Una calidad absoluta, una red comercial propia y una infraestructura que engloba todos estos factores. Para nosotros, la infraestructura es un punto clave en el éxito de nuestros productos. El objetivo es que en nuestras instalaciones se produzca una perfecta combinación entre funcionalidad, versatilidad y distinción.

#### **EXTREME QUALITY, OUR OWN COMMERCIAL NETWORK AND INFRASTRUCTURE**

At Porcelanosa we base the success of our products on three premises; unconditional quality, a commercial network of our own and an infrastructure to embrace all these factors. We think the infrastructure is key to the success of our products. We want our installations to have a perfect combination of functionality, versatility and distinction.

#### **QUALIDADE TOTAL COMO INFRAESTRUTURA E REDE COMERCIAL PRÓPRIAS**

Na Porcelanosa destacámos o éxito dos nossos produtos em três parâmetros: Qualidade absoluta, uma rede comercial própria e uma infraestructura que engloba todos estes factores. Para nós, a infraestructura é ponto chave no éxito dos nossos productos. A nossa intenção é que estas produzam uma perfeita combinação entre funcionalidade, versatilidade e distinção.

#### **UNE QUALITÉ ABSOLUE, NOTRE PROPRE RÉSEAU COMMERCIAL ET NOS INFRASTRUCTURES**

Chez Porcelanosa, nous appuyons le succès de nos produits sur trois paramètres: une qualité absolue, son propre réseau commercial et une infrastructure qui regroupe tous ces facteurs. Pour nous, l'infrastructure est un élément clef dans le succès de nos produits. Dans nos installations nous voulons créer un parfait mariage entre fonctionnalité, variabilité et distinction.

#### **ABSOLUTE QUALITÄT, EIGENES VERTRIEBSNETZWERK UND UNSERE INFRASTRUKTUR.**

Die Grundlage für den Erfolg unserer Produkte beruht auf folgenden Prämissen:

- Eine einwandfreie Qualität.
  - Ein eigenes Vertriebsnetz.
  - Eine Infrastruktur, die alle diese Faktoren mit einbezieht.
- Die Infrastruktur ist die Grundvoraussetzung für den Erfolg unserer Produkte. Wir beabsichtigen in unseren Anlagen eine perfekte Kombination von Funktionalität, Vielfältigkeit und Lebensqualität zu schaffen.

#### **UNA QUALITÀ ASSOLUTA, RETE COMMERCIALE PROPRIA E NOSTRE INFRASTRUTTURE**

In Porcelanosa basiamo il successo dei nostri prodotti in tre concetti: Qualità assoluta, rete commerciale propria e una infrastruttura che incorpora tutti questi concetti. Per noi, le infrastrutture sono il punto più importante per il successo dei nostri prodotti. Il nostro obiettivo è che nei nostri stabilimenti si produca una perfetta combinazione tra funzionalità, versatilità e distinzione.

400  
SHOWROOMS

#### **TIENDAS**

Con más de 400 tiendas repartidas por todo el mundo; desde Madrid a Nueva York, pasando por ciudades como Londres, Milán o París, PORCELANOSA asegura así su presencia en los cinco continentes para mostrar el continuo avance en innovación y diseño de todos sus productos.

#### **SALLES D'EXPOSITION**

Nous comptons plus de 400 salles d'expositions réparties dans le monde ; de Madrid à New York en passant par Londres, Milan et Paris. Porcelanosa Grupo assure ainsi sa présence sur les cinq continents et ceci afin de montrer l'amélioration dans l'innovation et la conception de nos produits.

#### **LOJAS**

Com mais de 400 lojas repartidas por todo o mundo; de Madrid a Nova-Lorque, passando por cidades como Londres, Milão ou Paris, Porcelanosa Grupo assegura assim a sua presença nos cinco continentes para mostrar o contínuo progresso de inovação e design de todos os seus produtos.

#### **SHOWROOMS**

With more than 400 showrooms spread worldwide; from Madrid to New York, through cities like London, Milan or Paris, Porcelanosa Grupo thus assures its presence in the five continents to show the steady improvement in innovation and design of all its products.

#### **GLI SHOWROOMS**

Con più di 400 punti vendita sparsi in tutto il mondo; da Madrid a New York, passando per città quali Londra, Milano o Parigi, Porcelanosa Grupo garantisce così la sua presenza nei cinque continenti, rivelando la costante evoluzione delle tecnologie e del design di tutti i suoi prodotti.

#### **AUSSTELLUGEN**

Inzwischen sind es bereits über 400 Ausstellungen, die in der ganzen Welt verteilt sind, von Madrid, London, Mailand oder Paris bis nach New York. Auf diese Weise sichert Porcelanosa Grupo ihren ständigen Fortschritt in allen Kontinenten bei Innovation und Design ihrer Produkte aufzuzeigen.





## ENVIRONMENTAL COMMITMENT

The environmental commitment Porcelanosa has shown toward its immediate surroundings and the environment as a whole has characterized the company since its origins is clearly reflected by ECOTECH®.

ECOTECH® is a collection of environmental ideas and initiatives, including substantial yearly investment into systems for recycling water, waste re-use, environmental protection and energy saving and it is a ISO 14001 certified environmental management system.

## COMPROMESSO CON L'AMBIENTE CIRCOSTANTE

L'impegno acquisito da Porcelanosa fin dall'inizio della propria attività industriale nei confronti della natura e dell'ambiente nel suo complesso è evidente con ECOTECH®, un insieme di idee e di azioni che interessano l'ambiente, tra le quali si possono sottolineare i grandi investimenti effettuati ogni anno per i sistemi di riutilizzo dell'acqua, la valorizzazione dei rifiuti, la protezione dell'atmosfera e il risparmio energetico, o la certificazione del proprio sistema di gestione ambientale secondo le direttrici della norma ISO 14001.

## COMPROMISSO COM O MEDIO

O compromisso mantido pela Porcelanosa desde o início da sua actividade industrial no cuidado e respeito pelo ambiente natural e pelo meio ambiente no seu conjunto, manifestase a través da ECOTECH®, um compêndio de ideias e acções de carácter ambiental, entre as quais podemos destacar os grandes investimentos realizados todos os anos em sistemas de reaproveitamento de água, de valorização de resíduos, de protecção da atmosfera e de poupança de energia, assim como de certificação do seu sistema de gestão ambiental, isto de acordo com as directrizes da norma ISO 14001.

## L' ENGAGEMENT ENVERS L'ENVIRONNEMENT

Depuis le début de son activité industrielle, Porcelanosa c'est engagé à respecter l'environnement à travers ECOTECH®.

ECOTECH®, est un recueil d'idées et d'actions qui chaque année grâce à d'importants investissements dans des systèmes de réutilisations des eaux, de recyclage des déchets, de protection de l'atmosphère et d'économies d'énergie. Toutes ces actions et investissements nous ont permis d'atteindre la norme ISO14001. et ceci afin de montrer l'amélioration dans l'innovation et la conception de nos produits.

## KOMPROMISS MIT DER UMWELT

Seit Beginn ihrer gewerblichen Tätigkeit hat sich die Gruppe Porcelanosa dem Schutz und Respekt ihrer natürlichen Umgebung und der Umwelt insgesamt verschrieben. Dies wird durch ECOTECH® zum Ausdruck gebracht, die eine Zusammenfassung von Ideen und Aktionen zum Umweltschutz, zu denen vor allem kräftige Investitionen gehören, und jedes Jahr für Systeme zur Wiederaufbereitung von Wasser, Bewertung von Abfällen, Schutz gegen Luftverschmutzung und Energieeinsparungen getätigt werden. Auch die Zertifizierung ihres Umweltmanagementsystems nach den Richtlinien der ISO-Norm 14001 stellt diese Einstellung unter Beweis.



# COMPROMISSO CON EL MEDIO AMBIENTE

El compromiso adquirido por PORCELANOSA desde el inicio de su actividad industrial en el cuidado y respeto a su entorno natural y el medio ambiente en su conjunto, se pone de manifiesto a través de ECOTECH®, un compendio de ideas y actuaciones de carácter medioambiental, entre las que podemos destacar las fuertes inversiones realizadas cada año en sistemas de reaprovechamiento de aguas, valorización de residuos, protección de la atmósfera y ahorro energético, o la certificación de su sistema de gestión ambiental según las directrices de la norma ISO 14001.

## COMPROMISO DE MEJORA CONSTANTE

- En Porcelanosa solo consumimos energía eléctrica cuyo origen renovable esté garantizado.
- El 30% de la energía que utilizamos en Porcelanosa la generamos nosotros mismos.
- La iluminación de nuestras instalaciones es, en más de un 90%, de tipo led de alto rendimiento y bajo consumo.
- La mitad de nuestra superficie cubierta permite la entrada de luz natural disminuyendo el consumo eléctrico.
- Nuestro parque móvil interno está formado por vehículos eléctricos.
- Como parte de nuestro compromiso con el ecosistema que nos rodea, en 2020 reforebremos una zona forestal con 17.000 árboles.
- Más del 95% de los residuos generados por Porcelanosa son reutilizados, reciclados o valorizados.
- Hemos reducido el consumo de agua en nuestros procesos de fabricación de revestimiento un 20%.
- Minimizamos el uso de agua y gas rectificando en seco nuestras cerámicas.
- El 100% del agua residual es depurada y reutilizada para conseguir un vertido de 0 litros.
- Todas las colecciones fabricadas por Porcelanosa tienen entre un 10 y un 20% de material reciclado, con especial mención a las series Ecologic que alcanzan un 95%.
- Calculamos y reducimos nuestra huella de carbono todos los años, asegurando nuestro compromiso como economía circular.
- Nuestros productos contribuyen a la obtención de créditos o puntos en certificaciones LEED, BREAM y VERDE.

## ENGAGEMENT POUR UNE AMÉLIORATION CONSTANTE

- Chez Porcelanosa, nous n'utilisons que de l'énergie électrique dont l'origine renouvelable est garantie.
- 30 % de l'énergie que nous utilisons chez Porcelanosa est générée par nous-mêmes.
- L'éclairage de nos installations est, à plus de 90 %, de type led à haut rendement et à faible consommation.
- La moitié de notre surface couverte permet l'entrée de lumière naturelle de manière à diminuer la consommation électrique.
- Notre parc mobile interne est constitué de véhicules électriques.
- Dans le cadre de notre engagement envers l'écosystème qui nous entoure, nous allons replanter en 2020 une zone forestière avec 17 000 arbres.
- Plus de 95 % des déchets générés par Porcelanosa sont réutilisés, recyclés ou valorisés.
- Nous avons réduit la consommation d'eau de 20 % dans nos procédés de fabrication de revêtement.
- Nous minimisons l'utilisation de l'eau et du gaz en rectifiant nos céramiques à sec.
- 100 % des eaux usées sont purifiées et réutilisées pour obtenir un rejet de 0 litre.
- Toutes les collections produites par Porcelanosa contiennent entre 10 et 20 % de matériaux recyclés, avec une mention particulière pour les séries Ecologic qui atteignent 95 %.
- Nous calculons et réduisons notre empreinte carbone chaque année, en assurant notre engagement en tant qu'économie circulaire.
- Nos produits contribuent à l'obtention de crédits ou points dans les certifications LEED, BREAM et VERDE.

## COMMITMENT TO CONTINUOUS IMPROVEMENT

- At Porcelanosa, we only consume electricity from guaranteed renewable sources.
- We generate 30% of the energy we use at Porcelanosa ourselves.
- Over 90% of the lighting in our premises is high-performance, low-consumption led lighting.
- Half of our indoor surface area receives natural light, which reduces electricity consumption.
- Our in-house rolling stock is comprised of electric vehicles.
- As part of our commitment to the ecosystem we live in, in 2020 we plan to restore a forest area with 17,000 trees.
- More than 95% of the waste generated by Porcelanosa is reused, recycled or repurposed.
- We have reduced water consumption in our tile manufacturing processes by 20%.
- We minimize water and gas use by dry pressing our ceramics.
- 100% of the wastewater is purified and reused, producing 0 litres of discharge.
- All collections manufactured by Porcelanosa contain between 10 and 20% recycled material, with special mention of the Ecologic series, which contains 95% recycled materials.
- We calculate and reduce our carbon footprint every year, ensuring our commitment as a circular economy.
- Our products contribute to obtaining credits or points in LEED, BREAM and VERDE certifications.

## IMPEGNO PER UN MIGLIORAMENTO COSTANTE

- In Porcelanosa consumiamo solo energia elettrica di origine rinnovabile garantita.
- Il 30% dell'energia che utilizziamo in Porcelanosa la generiamo noi stessi.
- L'illuminazione delle nostre strutture è, per oltre il 90%, di tipo led ad alte prestazioni e basso consumo.
- La metà della nostra superficie coperta consente l'ingresso della luce naturale, riducendo il consumo di elettricità.
- Il nostro parco auto interno è costituito da veicoli elettrici.
- Come parte del nostro impegno verso l'ecosistema che ci circonda, nel 2020 ripopoleremo un'area forestale con 17.000 alberi.
- Oltre il 95% dei rifiuti generati da Porcelanosa viene riutilizzato, riciclato o recuperato.
- Abbiamo ridotto del 20% il consumo d'acqua nei nostri processi di produzione dei rivestimenti.
- Riduciamo al minimo l'uso di acqua e gas rettificando a secco le nostre ceramiche.
- Il 100% delle acque reflue viene purificato e riutilizzato per ottenere uno scarico di 0 litri.
- Tutte le collezioni prodotte da Porcelanosa possiedono tra il 10 e il 20% di materiale riciclato, con particolare riferimento alle serie Ecologic che raggiungono il 95%.
- Calcoliamo e riduciamo la nostra impronta di carbonio ogni anno, garantendo il nostro impegno come economia circolare.
- I nostri prodotti contribuiscono all'ottenimento di crediti o punti nelle certificazioni LEED, BREEM e VERDE.

## COMPROMISSO DE MELHORIA CONTÍNUA

- Na Porcelanosa consumimos apenas energia elétrica cuja origem renovável esteja garantida.
- 30% da energia que utilizamos na Porcelanosa é produzida por nós.
- A iluminação das nossas instalações é, em mais de 90%, de led de alto rendimento e baixo consumo.
- Metade da nossa superfície coberta permite a entrada de luz natural diminuindo o consumo elétrico.
- O nosso parque móvel interno é formado por veículos elétricos.
- Como parte do nosso compromisso para com o ecossistema que nos rodeia, reforestaremos em 2020 uma zona florestal com 17.000 árvores.
- Mais de 95% dos resíduos produzidos pela Porcelanosa são reutilizados, reciclados ou valorizados.
- Reduzimos em 20% o consumo de água nos nossos processos de produção de revestimento.
- Minimizamos a utilização de água e gás retificando a seco as nossas cerâmicas.
- 100% da água residual é depurada e reutilizada para obter um derrame de 0 litros.
- Todas as coleções produzidas pela Porcelanosa possuem entre 10 e 20% de material reciclado, com destaque especial nas séries Ecologic que atingem os 95%.
- Calculamos e reduzimos todos os anos a nossa pegada de carbono, assegurando o nosso compromisso como economia circular.
- Os nossos produtos contribuem para a obtenção de créditos ou pontos nas certificações LEED, BREAM e VERDE.

## VERPFLICHTUNG ZUR STÄNDIGEN VERBESSERUNG

- Bei Porcelanosa verwenden wir nur Strom aus garantiert erneuerbaren Energiequellen.
- 30 % der Energie, die wir bei Porcelanosa verwenden, erzeugen wir selbst.
- Die Beleuchtung unserer Einrichtungen besteht zu mehr als 90 % aus LED-Leuchtmittel mit hoher Leistung und niedrigem Verbrauch.
- Die Hälfte unserer überdachten Fläche lässt natürliches Licht eindringen und reduziert so den Stromverbrauch.
- Unser interner Fuhrpark besteht aus Elektrofahrzeugen.
- Im Rahmen unseres Engagements für das uns umgebende Ökosystem werden wir 2020 ein Waldgebiet mit 17.000 Bäumen aufforsten.
- Über 95 % der von Porcelanosa erzeugten Abfälle werden wiederverwendet, recycelt oder verwertet.
- Wir haben den Wasserverbrauch in unseren Beschichtungsprozessen um 20 % reduziert.
- Durch das Trockenschleifen unserer Keramik reduzieren wir den Einsatz von Wasser und Gas auf ein Minimum.
- 100 % des Abwassers werden gereinigt und wiederverwendet, um einen Abfluss von 0 Litern zu erreichen.
- Alle von Porcelanosa hergestellten Kollektionen werden zu 10 bis 20 % aus recyceltem Material hergestellt. Die Ecologic-Reihe besteht sogar zu 95 % aus recyceltem Material.
- Wir berechnen und reduzieren jährlich unseren CO2-Fußabdruck und verpflichten uns damit zur Kreislaufwirtschaft.
- Unsere Produkte tragen dazu bei, Credits oder Punkte für LEED-, BREAM- und GREEN-.

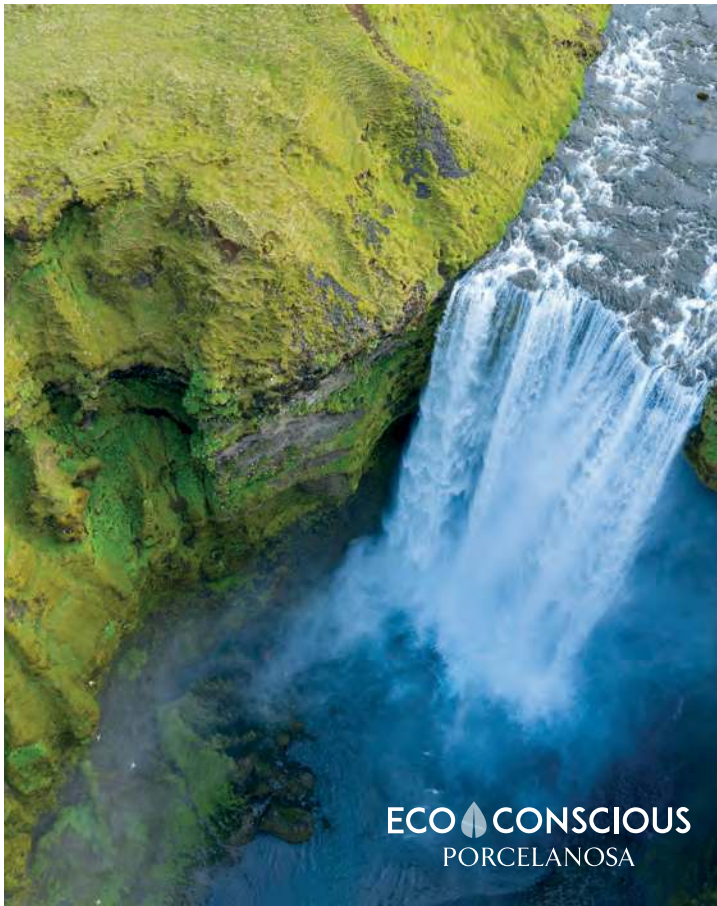

# ÍNDICE

# INDEX

NOMBRE NAME	FORMATO FORMAT	CÓDIGO CODE	PÁG. PAGE
<b>A</b>			
ACAPULCO CALIZA	45x120	6274	31
ANTIQUE AGERO	59,6x59,6	6359	259
ANTIQUE BLACK	59,6x59,6	6359	259
ANTIQUE BLUE	31,6x90	6271	85
ANTIQUE GREY	31,6x90	6271	85
ANTIQUE SILVER	59,6x59,6	6359	259
ARIZONA ARENA	49,5x85,9	6344	201
ARIZONA ARENA ANT.	49,5x85,9	6354	201
ARIZONA CALIZA	49,5x85,9	6344	201
ARIZONA CALIZA ANT.	49,5x85,9	6354	201
ARIZONA STONE	49,5x85,9	6344	201
ARIZONA STONE ANT.	49,5x85,9	6354	201
ASCOT ARGE	19,3x120	6384	164
ASCOT ARGE ANT.	19,3x120	6384	164
ASCOT ARGE	29,4x120	6384	164
ASCOT TEGA	19,3x120	6384	165
ASCOT TEGA ANT.	19,3x120	6384	165
ASCOT TEGA	29,4x120	6384	165
ASTON AGERO	59,6x59,6	6354	235
<b>B</b>			
BALI NIEVE	31,6x90	6261	103
BALI NIEVE	25x44,3	6211	158
BALI NIEVE	44,3x44,3	6311	103
BARBADOS BASE	31,6x90	6261	105
BARBADOS TOPO	31,6x90	6271	105
BARCELONA B	59,6x59,6	6359	275
BARCELONA C	59,6x59,6	6359	275
BARCELONA D	59,6x59,6	6359	275
BARCELONA E	59,6x59,6	6359	275
BARI BLANCO	31,6x90	6261	91
BARI BLANCO	59,6x59,6	6347	301
BELIDE AGERO	31,6x90	6271	77
BELIDE GALIZA	31,6x90	6271	79
BERNA AGERO	45x120	6270	20
BERNA AGERO	120x120	6392	204
BERNA AGERO ANT.	120x120	6393	204
BERNA AGERO	80x80	6369	204
BERNA AGERO	59,6x59,6	6354	204
BERNA GALIZA	45x120	6270	21
BERNA GALIZA	120x120	6392	205
BERNA GALIZA ANT.	120x120	6393	205
BERNA GALIZA	80x80	6369	205
BERNA GALIZA	59,6x59,6	6354	205
BERNA GREY	59,6x180	6371	204
BERNA GREY	120x120	6392	204
BERNA GREY ANT.	120x120	6393	204
BERNA GREY	80x80	6369	204
BERNA GREY	59,6x59,6	6354	204
BERNA TOPO	59,6x180	6371	205
BERNA TOPO	120x120	6392	205
BERNA TOPO ANT.	120x120	6393	205
BERNA TOPO	80x80	6369	205

NOMBRE NAME	FORMATO FORMAT	CÓDIGO CODE	PÁG. PAGE
BERNA TOPO	49,5x85,9	6344	205
BERNA TOPO ANT.	49,5x85,9	6354	205
BERNA TOPO	59,6x59,6	6354	205
BIANGO PUL.	59,6x118,7	6389	285
BLUESTONE AGERO	59,6x59,6	6354	209
BOMBAY NANTES	45x120	6274	99,35,37
BOMBAY NANTES	59,6x59,6	6354	255
BOSTON BONE	59,6x180	6371	211
BOSTON BONE	49,5x85,9	6344	211
BOSTON GRAFTO	49,5x85,9	6344	211
BOSTON GRAFTO ANT.	49,5x85,9	6354	211
BOSTON STONE	59,6x180	6371	211
BOSTON STONE	49,5x85,9	6344	211
BOSTON STONE ANT.	49,5x85,9	6354	211
BOSTON TOPO	31,6x90	6261	73
BOSTON TOPO	59,6x180	6371	211
BOSTON TOPO	49,5x85,9	6344	211
BOSTON TOPO ANT.	49,5x85,9	6354	211
BOTTEGA AGERO	59,6x180	6371	236
BOTTEGA AGERO	45x120	6270	25
BOTTEGA AGERO	31,6x59,2	6226	192
BOTTEGA AGERO	25x44,3	6211	150
BOTTEGA AGERO	120x120	6392	236
BOTTEGA AGERO ANT.	120x120	6393	236
BOTTEGA AGERO	80x80	6369	236
BOTTEGA AGERO ANT.	80x80	6373	236
BOTTEGA AGERO	60,2x80,2	6393	299
BOTTEGA AGERO ANT.	60,2x80,2	6393	299
BOTTEGA AGERO	59,6x59,6	6354	236
BOTTEGA AGERO G-2	59,6x59,6	6354	236
BOTTEGA AGERO ANT.	59,6x59,6	6359	236
BOTTEGA AGERO	44,3x44,3	6311	313
BOTTEGA AGERO G-2	44,3x44,3	6311	313
BOTTEGA AGERO ANT.	44,3x44,3	6311	313
BOTTEGA GALIZA	59,6x180	6371	236
BOTTEGA GALIZA	45x120	6270	27
BOTTEGA GALIZA	31,6x90	6261	75
BOTTEGA GALIZA	31,6x59,2	6226	192
BOTTEGA GALIZA	25x44,3	6211	150
BOTTEGA GALIZA	120x120	6392	236
BOTTEGA GALIZA ANT.	120x120	6393	236
BOTTEGA GALIZA	80x80	6369	236
BOTTEGA GALIZA ANT.	80x80	6373	236
BOTTEGA GALIZA	60,2x80,2	6393	299
BOTTEGA GALIZA ANT.	60,2x80,2	6393	299
BOTTEGA GALIZA	59,6x59,6	6354	236
BOTTEGA GALIZA ANT.	59,6x59,6	6359	236
BOTTEGA GALIZA G-2	59,6x59,6	6354	236
BOTTEGA TOPO	59,6x59,6	6354	237
BOTTEGA TOPO ANT.	59,6x59,6	6359	237
BOTTEGA GALIZA	44,3x44,3	6311	313
BOTTEGA GALIZA G-2	44,3x44,3	6311	313
BOTTEGA GALIZA ANT.	44,3x44,3	6311	313

NOMBRE NAME	FORMATO FORMAT	CÓDIGO CODE	PÁG. PAGE
BOTTEGA TOPO	120x120	6392	237
BOTTEGA TOPO ANT.	120x120	6393	237
BOTTEGA TOPO	80x80	6369	237
BOTTEGA TOPO ANT.	80x80	6373	237
BOTTEGA WHITE	45x120	6270	28
BOTTEGA WHITE	31,6x59,2	6226	193
BOTTEGA WHITE	120x120	6392	237
BOTTEGA WHITE	80x80	6369	237
BOTTEGA WHITE	59,6x59,6	6354	237
BOTTEGA WHITE	44,3x44,3	6311	313
BOTTEGA ANTRACITA	45x120	6270	28
BOTTEGA ANTRACITA	120x120	6392	237
BOTTEGA ANTRACITA ANT.	120x120	6393	237
BOTTEGA ANTRACITA	80x80	6369	237
BOTTEGA ANTRACITA ANT.	80x80	6373	237
BOTTEGA ANTRACITA	59,6x59,6	6354	237
BOTTEGA ANTRACITA ANT.	59,6x59,6	6359	237
BRUNI BLANCO	31,6x90	6261	120
<b>C</b>			
CALACATA GOLD	31,6x90	6261	93
CALACATA GOLD	59,6x59,6	6347	302
CALACATA SILVER	31,6x90	6261	93
CALACATA SILVER	59,6x59,6	6347	302
CAPRI BONE	45x120	6270	59
CAPRI LINEAL BONE	45x120	6274	59
CAPRI LINEAL STONE	45x120	6274	59
CAPRI STONE	45x120	6270	59
CARRARA BLANCO BRILLO	59,6x59,6	6347	303
CARRARA BLANCO BRILLO	49,5x49,5	6331	303
CARRARA BLANCO BRILLO	44,3x44,3	6319	320
CARRARA BLANCO NATURAL	59,6x120	6369	298
CARRARA BLANCO NATURAL	59,6x59,6	6347	298
CARRARA BLANCO PUL.	59,6x118,7	6389	287
CEILAN MARFIL	80x80	6369	215
CEILAN MARFIL	59,6x59,6	6354	215
CEPPO AGERO	80x80	6369	217
CEPPO STONE	80x80	6369	217
CHESTER AGERO	22x90	6372	169
CHESTER LENO	22x90	6372	169
CHINA BLANCO	31,6x59,2	6226	144
CHINA BLANCO	25x44,3	6211	156
COLUMBIA SILVER	45x120	6296	61
<b>D</b>			
DECO BERNA	45x120	6274	20,21
DECO BERNA	59,6x59,6	6359	205
DECO BOSTON TOPO	31,6x90	6271	73
DECO DURANGO	59,6x150	6278	15
DECO DURANGO	31,6x90	6271	81
DECO HARLEM AGERO	59,6x59,6	6359	245
DECO HARLEM GALIZA	59,6x59,6	6359	245
DECO MATT	45x120	6274	56
DECO MATT CLUB	45x120	6274	57
DOVER RODANO	31,6x59,2	6233	138

NOMBRE NAME	FORMATO FORMAT	CÓDIGO CODE	PÁG. PAGE
DECO STUDIO METAL	31,6x90	6287	119
DECO STUDIO TAUPE	31,6x90	6271	118
DECO STUDIO WHITE	31,6x90	6271	117
DELAWARE NATURAL	29,4x180	6386	170
DELAWARE NATURAL	19,3x180	6386	170
DELAWARE NATURAL	29,4x120	6384	170
DELAWARE NATURAL	19,3x120	6384	170
DELAWARE NATURAL ANT.	19,3,4x180	6386	170
DELAWARE NOGAL	29,4x180	6386	171
DELAWARE NOGAL	19,3x180	6386	171
DELAWARE NOGAL	29,4x120	6384	171
DELAWARE NOGAL	19,3x120	6384	171
DELAWARE NOGAL ANT.	19,3x180	6386	171
DOVER AGERO	31,6x90	6261	77
DOVER AGERO	31,6x59,2	6226	135
DOVER AGERO	80x80	6369	241
DOVER AGERO	59,6x59,6	6354	241
DOVER AGERO ANT.	59,6x59,6	6359	241
DOVER AGERO	44,3x44,3	6311	314
DOVER ANTIQUE	31,6x90	6271	77,78,79
DOVER ANTIQUE	31,6x59,2	6233	135
DOVER ANTIQUE	59,6x59,6	6359	241
DOVER ARENA	31,6x90	6261	78
DOVER ARENA	59,6x59,6	6354	241
DOVER ARENA ANT.	59,6x59,6	6359	241
DOVER GALIZA	31,6x90	6261	79
DOVER GALIZA	31,6x59,2	6226	135
DOVER GALIZA	80x80	6369	241
DOVER GALIZA	59,6x59,6	6354	241
DOVER GALIZA ANT.	59,6x59,6	6359	241
DOVER GALIZA	44,3x44,3	6311	314
DOVER MODERN LINE AGERO	31,6x90	6271	77
DOVER MODERN LINE AGERO	31,6x59,2	6233	135
DOVER MODERN LINE ARENA	31,6x90	6271	78
DOVER MODERN LINE GALIZA	31,6x90	6271	79
DOVER MODERN LINE GALIZA	31,6x59,2	6233	135
DOVER SPIGA GALIZA	31,6x90	6271	79
DURANGO AGERO	59,6x150	6278	14
DURANGO AGERO	31,6x90	6261	81
DURANGO AGERO	100x100	6377	219
DURANGO AGERO ANT.	100x100	6382	219
DURANGO AGERO	59,6x59,6	6354	219
DURANGO AGERO ANT.	59,6x59,6	6359	219
DURANGO BONE	59,6x150	6278	14
DURANGO BONE	31,6x90	6261	81
DURANGO BONE	100x100	6377	219
DURANGO BONE ANT.	100x100	6382	219
DURANGO BONE	59,6x59,6	6354	219
DURANGO BONE ANT.	59,6x59,6	6359	219
DURANGO SILVER	100x100	6377	219
DURANGO SILVER ANT.	100x100	6382	219
DURANGO SILVER	59,6x59,6	6354	219
DURANGO SILVER ANT.	59,6x59,6	6359	219

NOMBRE NAME	FORMATO FORMAT	CÓDIGO CODE	PÁG. PAGE
DURANGO TOPO	100x100	6377	219
DURANGO TOPO ANT.	100x100	6382	219
DURANGO TOPO	59,6x59,6	6354	219
DURANGO TOPO ANT.	59,6x59,6	6359	219
<b>E</b>			
EXTREME WHITE	59,6x120	6389	289
EXTREME WHITE	59,6x59,6	6354	289
<b>F</b>			
FONTANA	59,6x150	6276	17
FONTANA	25x44,3	6211	153
FONTANA	59,6x59,6	6347	304
FONTANA MATT	44,3x44,3	6311	321
FOREST AGERO	14,3x90	6340	175
FOREST AGERO ANT.	14,3x90	6340	175
FOREST AGERO	22x90	6340	175
FOREST ARCE	14,3x90	6340	175
FOREST ARCE ANT.	14,3x90	6340	175
FOREST ARCE	22x90	6340	175
FOREST COGNAC	14,3x90	6340	174
FOREST COGNAC	22x90	6340	174
FOREST COGNAC ANT.	14,3x90	6340	174
FOREST COLONIAL	14,3x90	6340	174
FOREST COLONIAL ANT.	14,3x90	6340	



NOMBRE NAME	FORMATO FORMAT	CÓDIGO CODE	PÁG. PAGE
JAPAN MARINE	31,6x90	0261	121
JAPAN MARINE	31,6x59,2	0226	147
JAPAN MARINE	25x44,3	0211	159
JAPAN MARINE	44,3x44,3	0311	323
JERSEY MIX	31,6x90	0271	103
JERSEY MIX	25x44,3	0230	158
JERSEY NIEVE	31,6x90	0271	103
<b>K</b>			
KARACHI AGERO	100x100	0377	249
KARACHI GREY	100x100	0377	249
KINGSTON NAGAR	31,6x59,2	0226	149
<b>L</b>			
LEXINGTON COGNAC	45x120	0274	63
LEXINGTON COLONIAL	45x120	0274	63
LEXINGTON MAPLE	45x120	0274	63
LINE MATT	45x120	0274	56
LINO BLANCO	31,6x90	0261	107
LISTON MADERA ROBLE	45x120	0274	65
LISTON OXFORD COGNAC	31,6x90	0271	123
LISTON OXFORD NATURAL	31,6x90	0271	123
<b>M</b>			
MADISON ANTRACITA	31,6x90	0271	125
MADISON NAGAR	31,6x90	0271	125
MADISON PLATA	31,6x90	0287	125
MANHATTAN COGNAC	29,4x180	0386	178
MANHATTAN COGNAC	19,3x180	0386	178
MANHATTAN COGNAC	29,4x120	0384	178
MANHATTAN COGNAC	19,3x120	0384	178
MANHATTAN COGNAC ANT.	19,3x180	0386	178
MANHATTAN COLONIAL	29,4x180	0386	179
MANHATTAN COLONIAL	19,3x180	0386	179
MANHATTAN COLONIAL	29,4x120	0384	179
MANHATTAN COLONIAL	19,3x120	0384	179
MANHATTAN COLONIAL ANT.	19,3x180	0386	179
MANHATTAN MAPLE	29,4x180	0386	179
MANHATTAN MAPLE	19,3x180	0386	179
MANHATTAN MAPLE	29,4x120	0384	179
MANHATTAN MAPLE	19,3x120	0384	179
MANHATTAN MAPLE ANT.	19,3x180	0386	179
MARBELLA BLUE	45x120	0274	29
MARBELLA STONE	45x120	0274	29
MARBELLA STONE	31,6x90	0271	75
MARBELLA STONE	31,6x59,2	0233	133
MARBELLA STONE	25x44,3	0230	150
MARBELLA STONE	59,6x59,6	0359	237
MARMI BLANCO	31,6x90	0261	111
MARMI BLANCO	31,6x59,2	0240	111
MARMI BLANCO XL	45x120	0270	52
MARMI BLANCO	59,6x59,6	0347	312
MARMI CHINA XXL	59,6x150	0276	19
MARMI CHINA XL	45x120	0270	53
MARMI CHINA	31,6x90	0261	109
MARMI CHINA	31,6x59,2	0240	109

NOMBRE NAME	FORMATO FORMAT	CÓDIGO CODE	PÁG. PAGE
MARMI DEGO BLANCO	31,6x90	0271	111
MARVEL PUL.	59,6x118,7	0389	289
MATT	45x120	0270	56
MATT CLUB	45x120	0274	57
MATT WHITE	59,6x59,6	0354	271
MEAUX AGERO	60,2x60,2	0393	300
MEDICI NANTES AGERO	45x120	0274	33
MEDICI NANTES ARENA	45x120	0274	35
MEDICI NANTES GALIZA	45x120	0274	37
MEMORCA BLANCO	31,6x90	0261	113
MEMORCA HOJAS GRIS	31,6x90	0271	113
MEMORCA HOJAS TOPO	31,6x90	0271	113
MEMORCA LINE GRIS	31,6x90	0271	113
MEXIGO GALIZA	45x120	0270	31
MEXIGO GALIZA	59,6x59,6	0354	251
MICROGEMENTO BLANCO	59,6x59,6	0354	253
MILANO TOPO	45x120	0270	49
MILANO TOPO	59,6x59,6	0347	305
MOMBASA PRADA AGERO	45x120	0274	39
MOMBASA PRADA GALIZA	45x120	0274	41
MOMBASA PRADA WHITE	45x120	0274	43
MOSAICO CARRARA BLANCO	31,6x90	0271	95
MOSAICO BERNA AGERO	45x120	0274	20
MOSAICO BERNA GALIZA	45x120	0274	21
MOSAICO DURANGO	59,6x150	0278	15
MOSAICO DURANGO	31,6x90	0271	81
MOSAICO MATT	45x120	0274	56
MOSAICO NANTES AGERO	45x120	0274	33
MOSAICO NANTES AGERO	31,6x59,6	0233	136
MOSAICO NANTES ARENA	45x120	0274	35
MOSAICO NANTES GALIZA	45x120	0274	37
MOSAICO NANTES GALIZA	31,6x59,6	0233	136
MOSAICO PRADA AGERO	45x120	0274	39
MOSAICO PRADA GALIZA	45x120	0274	41
MOSAICO PRADA WHITE	45x120	0274	43
MOSAICO RECIFE GRIS	31,6x90	0271	99
MOSAICO RODANO AGERO	31,6x90	0271	86
MOSAICO RODANO AGERO	31,6x59,2	0233	138
MOSAICO RODANO GALIZA	31,6x90	0271	87
MOSAICO RODANO GALIZA	31,6x59,2	0233	139
MOSAICO RODANO SILVER	31,6x90	0271	87
MOSAICO RODANO SILVER	31,6x59,2	0233	139
MOSAICO STUDIO METAL	31,6x90	0287	119
MOSAICO STUDIO TAUPE	31,6x90	0271	118
MOSAICO STUDIO WHITE	31,6x90	0271	117
MALAGA AGERO	25x44,3	0230	154
MALAGA AQUA	25x44,3	0230	154
MALAGA BEIGE	25x44,3	0230	154
MALAGA OCEAN	25x44,3	0230	154
MALAGA WHITE	25x44,3	0230	154
MARMOL CARRARA BLANCO XL	45x120	0270	47
MARMOL CARRARA BLANCO	31,6x90	0261	95
MARMOL CARRARA BLANCO	31,6x59,2	0226	142

NOMBRE NAME	FORMATO FORMAT	CÓDIGO CODE	PÁG. PAGE
<b>N</b>			
NANTES AGERO	45x120	0270	33
NANTES AGERO	31,6x59,6	0226	136
NANTES AGERO	120x120	0392	255
NANTES AGERO	59,6x59,6	0354	255
NANTES AGERO	44,3x44,3	0311	315
NANTES AGERO ANT.	59,6x59,6	0359	255
NANTES ARENA	45x120	0270	35
NANTES ARENA	59,6x59,6	0354	255
NANTES ARENA ANT.	59,6x59,6	0359	255
NANTES GALIZA	45x120	0270	37
NANTES GALIZA	31,6x59,6	0226	136
NANTES GALIZA	120x120	0392	255
NANTES GALIZA	59,6x59,6	0354	255
NANTES GALIZA	44,3x44,3	0311	315
NANTES GALIZA ANT.	59,6x59,6	0359	255
NAST ARENA	44,3x44,3	0311	316
NAST BLANCO	31,6x59,2	0226	137
NAST BLANCO	44,3x44,3	0311	316
NAST BROWN	31,6x59,2	0226	137
NAST BROWN	44,3x44,3	0311	316
NAST BROWN	31,6x59,2	0226	137
NAST GALIZA	31,6x59,2	0226	137
NAST GALIZA	44,3x44,3	0311	316
NAST GALIZA	44,3x44,3	0311	316
NAST DARK	31,6x59,2	0226	137
NAST DARK	44,3x44,3	0311	316
NAST DARK	31,6x59,2	0226	137
NAST DARK	44,3x44,3	0311	316
NAST GREY	31,6x59,2	0226	137
NAST GREY	44,3x44,3	0311	316
NIMBUS BLANCO	25x44,3	0211	151
NIMBUS BLANCO	44,3x44,3	0311	317
NIMBUS SILVER	25x44,3	0211	151
NIMBUS SILVER	44,3x44,3	0311	317
NOBU ARCE	29,4x180	0386	182
NOBU ARCE	19,3x180	0386	182
NOBU ARCE ANT.	19,3x180	0386	182
NOBU ROBLE	29,4x180	0386	183
NOBU ROBLE	19,3x180	0386	183
NOBU ROBLE ANT.	19,3x180	0386	183
NOVA	44,3x44,3	0311	322
<b>O</b>			
OLIMPO MARFIL	31,6x90	0261	97
OLIMPO MARFIL	59,6x59,6	0347	306
ORLEANS ARCE	19,3x120	0387	186
ORLEANS ARCE ANT.	19,3x120	0387	186
ORLEANS GREY	19,3x120	0387	186
ORLEANS GREY ANT.	19,3x120	0387	186
ORLEANS NATURAL	19,3x120	0387	187
ORLEANS NATURAL ANT.	19,3x120	0387	187
ORLEANS NUT	19,3x120	0387	187
ORLEANS NUT ANT.	19,3x120	0387	187
ORLEANS ROBLE	19,3x120	0387	187
ORLEANS ROBLE ANT.	19,3x120	0387	187
OXFORD AGERO	22x90	0372	190
OXFORD AGERO	14,3x90	0372	190

NOMBRE NAME	FORMATO FORMAT	CÓDIGO CODE	PÁG. PAGE
OXFORD AGERO ANT.	14,3x90	0372	190
OXFORD ANTRACITA	22x90	0372	190
OXFORD ANTRACITA	14,3x90	0372	190
OXFORD ANTRACITA ANT.	14,3x90	0372	190
OXFORD BLANCO	22x90	0372	190
OXFORD BLANCO	14,3x90	0372	190
OXFORD BLANCO ANT.	14,3x90	0372	190
OXFORD CASTAÑO	22x90	0372	191
OXFORD CASTAÑO	14,3x90	0372	191
OXFORD CASTAÑO ANT.	14,3x90	0372	191
OXFORD COGNAC	22x90	0372	191
OXFORD COGNAC	14,3x90	0372	191
OXFORD COGNAC ANT.	14,3x90	0372	191
OXFORD NATURAL	22x90	0372	191
OXFORD NATURAL	14,3x90	0372	191
OXFORD NATURAL ANT.	14,3x90	0372	191
OXFORD SILVER	22x90	0372	191
OXFORD SILVER	14,3x90	0372	191
OXFORD SILVER ANT.	14,3x90	0372	191
OXO DEGO BLANCO	31,6x90	0271	109
OXO DEGO BLANCO	31,6x59,2	0233	144
OXO DEGO XL	45x120	0274	53
OXO LINE BLANCO	31,6x90	0271	109
OXO LINE XL	45x120	0274	53
<b>P</b>			
PARK AGERO	31,6x90	0261	85
PARK AGERO	59,6x59,6	0354	258
PARK BLANCO	25x44,3	0211	152
PARK BLANCO	44,3x44,3	0311	318
PARK GRIS	25x44,3	0211	152
PARK GRIS	44,3x44,3	0311	318
PARK LINEAL AGERO	31,6x90	0271	85
PARK LINEAL BLANCO	25x44,3	0230	152
PARK LINEAL GRIS	25x44,3	0230	152
PERSIA	45x120	0270	51
PERSIA	59,6x59,6	0347	307
PORTOFINO PUL.	59,6x118,7	0389	291
PRADA AGERO	45x120	0270	39
PRADA AGERO	120x120	0392	223
PRADA AGERO	59,6x59,6	0354	223
PRADA AGERO ANT.	59,6x59,6	0359	223
PRADA GALIZA	45x120	0270	41
PRADA GALIZA	59,6x59,6	0354	223
PRADA GALIZA ANT.	59,6x59,6	0359	223
PRADA WHITE	45x120	0270	43
PRADA WHITE	59,6x59,6	0354	223
<b>Q</b>			
QATAR NAGAR	31,6x90	0271	115
<b>R</b>			
RECIFE GRIS	31,6x90	0261	99
RECIFE GRIS	43,5x43,5	0331	308
RETRO STUDIO METAL	31,6x90	0287	119
RETRO STUDIO TAUPE	31,6x90	0271	118

NOMBRE NAME	FORMATO FORMAT	CÓDIGO CODE	PÁG. PAGE
RETRO STUDIO WHITE	31,6x90	0271	117
RIVER ANTRACITA	59,6x120	0373	227
RIVER ANTRACITA ANT.	59,6x120	0373	227
RIVER SILVER	59,6x120	0369	227
RIVER SILVER ANT.	59,6x120	0373	227
RIVER STONE	59,6x120	0369	227
RIVER STONE ANT.	59,6x120	0373	227
RODANO AGERO	31,6x90	0261	86
RODANO AGERO	31,6x59,2	0226	138
RODANO AGERO	120x120	0392	261
RODANO AGERO	80x80	0369	261
RODANO AGERO	59,6x59,6	0354	261
RODANO AGERO	44,3x44,3	0311	319
RODANO AGERO ANT.	120x120	0393	261
RODANO AGERO ANT.	59,6x59,6	0359	261
RODANO GALIZA	31,6x90	0261	87
RODANO GALIZA	31,6x59,2	0226	139
RODANO GALIZA	59,6x59,6	0354	261
RODANO GALIZA	44,3x44,3	0311	319
RODANO LINEAL AGERO	31,6x59,2	0233	138
RODANO LINEAL GALIZA	31,6x59,2	0233	139
RODANO SILVER	31,6x90	0261	87
RODANO SILVER	59,6x59,6	0354	261
RODANO SILVER ANT.	59,6x59,6	0359	261
RODANO TAUPE	31,6x59,2	0226	139
RODANO TAUPE	44,3x44,3	0311	319
RONDA AQUA	25x44,3	0230	155
RONDA MINT	25x44,3	0230	155
RONDA WHITE	25x44,3	0230	155
ROYAL PULIDO	59,6x118,7	0389	293
<b>S</b>			
SAFARI ARENA	31,6x90	0261	126
SAFARI ARENA	59,6x59,6	0354	277
SAFARI GALIZA	31,6x90	0261	126
SAFARI GALIZA	59,6x59,6	0354	277
SAMOA ANTRACITA	43,5x85,9	0344	281
SAMOA ANTRACITA ANT.	43,5x85,9	0354	281
SENA AGERO	31,6x90	0369	101
SENA AGERO	31,6x59,2	0373	143
SENA AGERO	59,6x59,6	0347	309
SENA GALIZA	31,6x90	0261	101
SENA GALIZA	31,6x59,2	0226	143
SENA GALIZA	59,6x59,6	0347	309
SEUL NAGAR	31,6x90	0261	115
SOCHI MARFIL PUL.	59,6x118,7	0389	295
SOCHI BLANCO PUL.	59,6x118,7	0389	295
SOHO AGERO	80x80	0369	265
SOHO AGERO ANT.	80x80	0373	265
SPIGA BOTTEGA ANTRACITA	45x120	0274	28
SPIGA BOTTEGA AGERO	45x120	0274	25
SPIGA BOTTEGA AGERO	31,6x59,2	0233	132
SPIGA BOTTEGA GALIZA	45x120	0274	27
SPIGA BOTTEGA GALIZA	31,6x59,2	0233	132

NOMBRE NAME	FORMATO FORMAT	CÓDIGO CODE	PÁG. PAGE



Grandes formatos para revestimientos que minimizan los tiempos de instalación, sobre todo en proyectos de gran envergadura y reducen el número de juntas entre piezas.

## **REVESTI- MIENTO XXL \_ XL**

*Large formats for wall tiles wich minimize installation times, especially in large projects, and reduce the number of joints between pieces.*

## **XXL \_ XL WALL TILES**



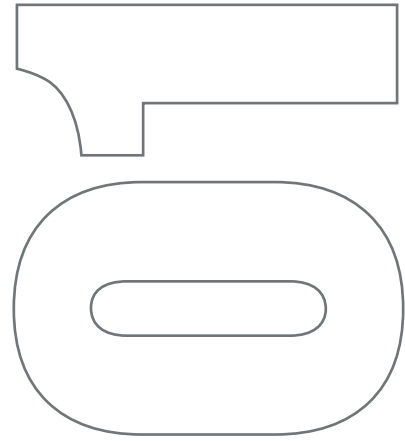

<b>XXL</b>			
	DECO DURANGO _ SPIGA DURANGO _ MOSAICO DURANGO _ DURANGO	14	<b>NEW</b>
	FONTANA	17	<b>NEW</b>
	SPIGA MARMI CHINA XXL _ MARMI CHINA XXL	19	<b>NEW</b>
<b>STONES &amp; CONCRETES</b>			
	DECO BERNA _ STRIPE BERNA _ MOSAICO BERNA _ BERNA	20	
	MARBELLA _ TWIN BOTTEGA _ SPIGA BOTTEGA _ BOTTEGA	25	
	ACAPULCO _ MÉXICO	31	
	BOMBAY NANTES _ MEDICI NANTES _ MOSAICO NANTES _ NANTES	33	
	SPIGA PRADA _ MOSAICO PRADA _ MOMBASA PRADA _ PRADA	39	
	TOSCANA DECO _ TOSCANA	45	
<b>MARBLES</b>			
	TRAVERTINO MEDICI _ MÁRMOL CARRARA BLANCO	47	
	MILANO	49	
	THASSOS _ PERSIA	51	
<b>WHITES</b>			
	MARMI BLANCO XL	52	
	OXO LINE XL _ OXO DECO XL _ SPIGA MARMI CHINA XL _ MARMI CHINA XL	53	<b>NEW</b>
	MATT CLUB _ DECO MATT CLUB _ LINE MATT _ STRIPE MATT _ DECO MATT _ MOSAICO MATT _ MATT	56	<b>NEW</b>
<b>TEXTURES</b>			
	CAPRI LINEAL _ CAPRI	59	
	COLUMBIA	61	
	LEXINGTON	63	
	LISTÓN MADERA	65	
	SPIGA	67	

# DURANGO

Revestimiento Monoporosa Rectificado / Rectified Wall Tiles



NEW



## DURANGO ACERO

59,6 cm x 150 cm x 1,02 cm P9760004 / 100272816 G276

## PERFIL DURANGO ACERO

1,5 cm x 59,6 cm P9210853 / 100274438 G92

Butech: Colorstuk Rapid n Gris B21522258/100236834



## DURANGO BONE

59,6 cm x 150 cm x 1,02 cm P9760002 / 100272858 G276

## PERFIL DURANGO BONE

1,5 cm x 59,6 cm P9210859 / 100274490 G92

Butech: Colorstuk Rapid n Gris B21522258/100236834

### EMBALAJE / PACKING

MODELO MODEL	PZ/CJ	M2/CJ	*KG/CJ	CJ/PAL	M2/PAL	*KG/PAL	ADHESIVO ADHESIVE BUTECH
59,6 cm x 150 cm	3	2,68	47,11	20	53,64	942,18	Fr-one n / One-flex Premium
Perfil 1,5 cm x 59,6 cm	15	0,27	3,56	28	7,51	99,54	

\*valores aproximados. \*approximated values.

# MOSAICO DURANGO SPIGA DURANGO DECO DURANGO

Revestimiento Monoporosa Rectificado / Rectified Wall Tiles



NEW



## MOSAICO DURANGO

59,6 cm x 150 cm x 1,02 cm P9760006 / 100272817 G278

Butech: Colorstuk Rapid n Gris B21522258/100236834



## SPIGA DURANGO

59,6 cm x 150 cm x 1,02 cm P9760001 / 100272882 G278

Butech: Colorstuk Rapid n Gris B21522258/100236834



## DECO DURANGO

59,6 cm x 150 cm x 1,02 cm P9760000 / 100272857 G278

Butech: Colorstuk Rapid n Cemento B21522249/100236449

DECO DURANGO ESTÁ FORMADA POR 3 DECORADOS DISTINTOS ALEATORIOS.  
DECO DURANGO IS MADE IN 3 DIFFERENT RANDOM PATTERNS.





REV. / WALL TILE: FONTANA 59,6 cm x 150 cm

# FONTANA

Revestimiento Monoporosa Rectificado / Rectified Wall Tiles



**NEW**



**FONTANA**

59,6 cm x 150 cm x 1 cm P9760007 / 100272865 G276

**PERFIL FONTANA**

1,5 cm x 59,6 cm P9210855 / 100274458 G92

*Butech: Colorstuk Rapid n Gris B21522258/100236834*

**EMBALAJE / PACKING**

MODELO MODEL	PZ/CJ	M2/CJ	*KG/CJ	CJ/PAL	M2/PAL	*KG/PAL	ADHESIVO ADHESIVE BUTECH
59,6 cm x 150 cm	3	2,68	47,11	20	53,64	942,18	Fr-one n / One-flex Premium
Perfil 59,6 cm x 150 cm	15	0,27	3,56	28	7,51	99,54	

\*valores aproximados. \*approximated values.

PAVIMENTO COMBINABLE: SERIE FONTANA 59,6 x 59,6cm  
FLOOR TILES COMBINATIONS: FONTANA SERIE 59,6 x 59,6cm





REV. / WALL TILE: MARMÍ CHINA XXL 59,6 cm x 150 cm, SPIGA MARMÍ CHINA XXL 59,6 cm x 150 cm

# MARMÍ CHINA XXL SPIGA MARMÍ CHINA XXL

Revestimiento Monoporosa Rectificado / Rectified Wall Tiles



**NEW**

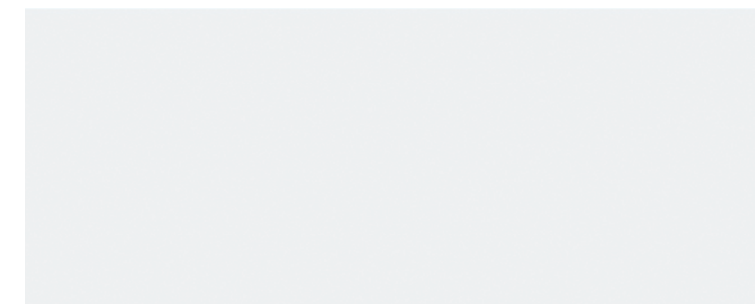

## MARMÍ CHINA XXL

59,6 cm x 150 cm x 1 cm P9760003 / 100272890 G276

## PERFIL MARMÍ CHINA

1,5 cm x 59,6 cm P5730112 / 100016285 G92

*Butech: Colorstuk Rapid n Blanco B21522247/100236463*



## SPIGA MARMÍ CHINA XXL

59,6 cm x 150 cm x 1 cm P9760005 / 100272872 G278

*Butech: Colorstuk Rapid n Blanco B21522247/100236463*



### EMBALAJE / PACKING

MODELO MODEL	PZ/CJ	M2/CJ	*KG/CJ	CJ/PAL	M2/PAL	*KG/PAL	ADHESIVO ADHESIVE BUTECH
59,6 cm x 150 cm	3	2,68	47,11	20	53,64	942,18	Fr-one n / One-flex Premium
Perfil 1,5 cm x 59,6 cm	15	0,27	3,56	28	7,51	99,54	

\*valores aproximados. \*approximated values.



# BERNA MOSAICO BERNA STRIPE BERNA DECO BERNA

Revestimiento Monoporosa Rectificado / Rectified Wall Tiles



**BERNA ACERO**  
45 cm x 120 cm x 1,02 cm P3580097 / 100245281 G270  
**PERFIL BERNACERO**  
1,5 cm x 45 cm P3800041 / 100246472 G92  
*Butech: Colorstuk Rapid n Manhattan B21522248/100236464*



**MOSAICO BERNACERO**  
45 cm x 120 cm x 0,96 cm P3580095 / 100245198 G274  
*Butech: Colorstuk Rapid n Manhattan B21522248/100236464*



**STRIPE BERNACERO**  
45 cm x 120 cm x 1,03 cm P3580101 / 100245260 G274  
*Butech: Colorstuk Rapid n Manhattan B21522248/100236464*



**DECO BERNACERO**  
45 cm x 120 cm x 1,03 cm P3580098 / 100245239 G274  
*Butech: Colorstuk Rapid n Manhattan B21522248/100236464*



DECO BERNACERO ESTÁ FORMADA POR 3 DECORADOS DISTINTOS ALEATORIOS.  
DECO BERNACERO IS MADE IN 3 DIFFERENT RANDOM PATTERNS.

# BERNA MOSAICO BERNA STRIPE BERNA DECO BERNACERO

Revestimiento Monoporosa Rectificado / Rectified Wall Tiles



**BERNACALIZA**  
45 cm x 120 cm x 1,02 cm P3580096 / 100245273 G270  
**PERFIL BERNACALIZA**  
1,5 cm x 45 cm P3800040 / 100246473 G92  
*Butech: Colorstuk Rapid n Beige B21522252/100236808*



**MOSAICO BERNACALIZA**  
45 cm x 120 cm x 0,96 cm P3580099 / 100245234 G274  
*Butech: Colorstuk Rapid n Beige B21522252/100236808*



**STRIPE BERNACALIZA**  
45 cm x 120 cm x 1,03 cm P3580100 / 100245235 G274  
*Butech: Colorstuk Rapid n Beige B21522252/100236808*



**DECO BERNACALIZA**  
45 cm x 120 cm x 1,03 cm P3580098 / 100245239 G274  
*Butech: Colorstuk Rapid n Manhattan B21522248/100236464*



DECO BERNACALIZA ESTÁ FORMADA POR 3 DECORADOS DISTINTOS ALEATORIOS.  
DECO BERNACALIZA IS MADE IN 3 DIFFERENT RANDOM PATTERNS.

## EMBALAJE / PACKING

MODELO MODEL	PZ/CJ	M2/CJ	*KG/CJ	CJ/PAL	M2/PAL	*KG/PAL	ADHESIVO ADHESIVE BUTECH
45 cm x 120 cm	3	1,62	28,18	40	64,84	1127,04	Fr-one n / One-flex Premium
Perfil 1,5 cm x 45 cm	20	0,27	3,64	56	15,12	203,84	

\*valores aproximados. \*approximated values.

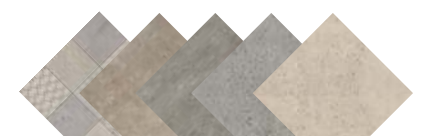

PAVIMENTO COMBINABLE: SERIE BERNACERO 59,6 cm x 59,6 cm  
FLOOR TILES COMBINATIONS: BERNACERO SERIE 59,6 cm x 59,6 cm





REV. / WALL TILE: BERNA CALIZA 45 cm x 120 cm, STRIPE BERNA CALIZA 45 cm x 120 cm \_RAV\_/ FLOOR TILE: MANHATTAN COLONIAL 19,3 cm x 120 cm / 29,4 cm x 120 cm





# BOTTEGA SPIGA BOTTEGA TWIN BOTTEGA

Revestimiento Monoporosa Rectificado / Rectified Wall Tiles



### BOTTEGA ACERO

45 cm x 120 cm x 1,01 cm P3580040 / 100214606 G270

### PEEFIL BOTTEGA ACERO

1,5 cm x 45 cm P3800020 / 100217891 G92

Butech: Colorstuk Rapid n Manhattan B21522248/100236464



### SPIGA BOTTEGA ACERO

45 cm x 120 cm x 1,01 cm P3580048 / 100214812 G274

Butech: Colorstuk Rapid n Manhattan B21522248/100236464



### TWIN BOTTEGA ACERO

45 cm x 120 cm x 1,04 cm P3580047 / 100214786 G274

Butech: Colorstuk Rapid n Manhattan B21522248/100236464 \_ Colorstuk Rapid n Blanco B21522247/100236463

### EMBALAJE / PACKING

MODELO MODEL	PZ/CJ	M2/CJ	*KG/CJ	CJ/PAL	M2/PAL	*KG/PAL	ADHESIVO ADHESIVE BUTECH
45 cm x 120 cm	3	1,62	27,9	40	64,84	1115,76	Fr-one n / One-flex Premium
Perfil 1,5 cm x 45 cm	20	0,27	3,64	56	15,12	203,84	

\*valores aproximados. \*approximated values.

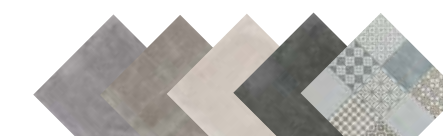

PAVIMENTO COMBINABLE: SERIE BOTTEGA 59,6 cm x 59,6 cm  
FLOOR TILES COMBINATIONS: BOTTEGA SERIE 59,6 cm x 59,6 cm





REV. / WALL TILE: BOTTEGA CALIZA 45 cm x 120 cm \_PAV. / FLOOR TILE: BOTTEGA ACERO 80 cm x 80 cm

# BOTTEGA SPIGA BOTTEGA TWIN BOTTEGA

Revestimiento Monoporosa Rectificado / Rectified Wall Tiles



**BOTTEGA CALIZA**  
 45 cm x 120 cm x 1,01 cm P3580044 / 100214661 G270  
**PERFIL BOTTEGA CALIZA**  
 1,5 cm x 45 cm P3800021 / 100219991 G92  
*Butech: Colorstuk Rapid n Gris B21522258/100236834*



**SPIGA BOTTEGA CALIZA**  
 45 cm x 120 cm x 1,01 cm P3580049 / 100214820 G274  
*Butech: Colorstuk Rapid n Gris B21522258/100236834*



**TWIN BOTTEGA CALIZA**  
 45 cm x 120 cm x 1,04 cm P3580046 / 100214794 G274  
*Butech: Colorstuk Rapid n Gris B21522258/100236834 \_ Colorstuk Rapid n Blanco B21522247/100236463*

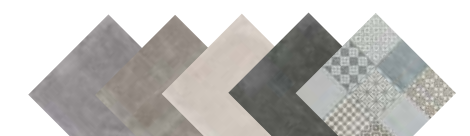

PAVIMENTO COMBINABLE: SERIE BOTTEGA 59,6 cm x 59,6 cm  
 FLOOR TILES COMBINATIONS: BOTTEGA SERIE 59,6 cm x 59,6 cm

## EMBALAJE / PACKING

MODELO MODEL	PZ/CJ	M2/CJ	*KG/CJ	CJ/PAL	M2/PAL	*KG/PAL	ADHESIVO ADHESIVE BUTECH
45 cm x 120 cm	3	1,62	27,9	40	64,84	1115,76	Fr-one n / One-flex Premium
Perfil 1,5 cm x 45 cm	20	0,27	3,64	56	15,12	203,84	

\*valores aproximados. \*approximated values.

# BOTTEGA SPIGA BOTTEGA

Revestimiento Monoporosa Rectificado / Rectified Wall Tiles



**BOTTEGA WHITE**  
 45 cm x 120 cm x 1,01 cm P3580067 / 100239817 G270  
**PERFIL BOTTEGA WHITE**  
 1,5 cm x 45 cm P3800037 / 100242234 G92  
*Butech: Colorstuk Rapid n Perla B21522263/100275760*



**BOTTEGA ANTRACITA**  
 45 cm x 120 cm x 1,01 cm P3580102 / 100245586 G270  
**PERFIL BOTTEGA ANTRACITA**  
 1,5 cm x 45 cm P3800038 / 100246448 G92  
*Butech: Colorstuk Rapid n Antracita B21522250/100236481*

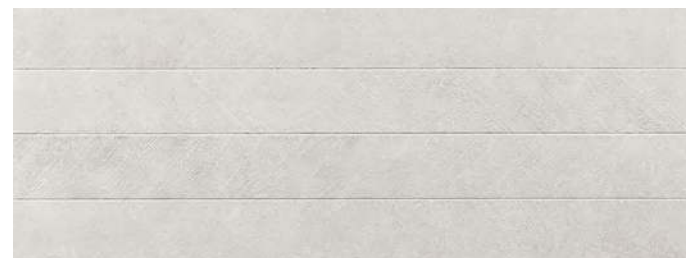

**SPIGA BOTTEGA WHITE**  
 45 cm x 120 cm x 1,01 cm P3580094 / 100245337 G274  
*Butech: Colorstuk Rapid n Perla B21522263/100275760*

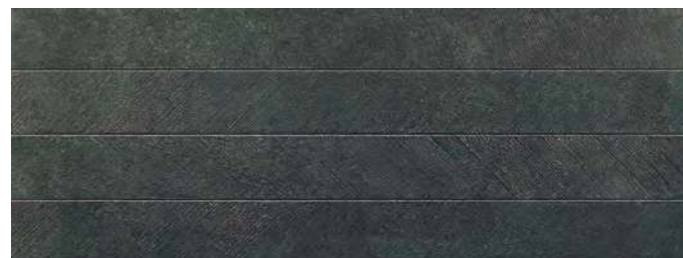

**SPIGA BOTTEGA ANTRACITA**  
 45 cm x 120 cm x 1,01 cm P3580103 / 100245585 G274  
*Butech: Colorstuk Rapid n Antracita B21522250/100236481*



## EMBALAJE / PACKING

MODELO MODEL	PZ/CJ	M2/CJ	*KG/CJ	CJ/PAL	M2/PAL	*KG/PAL	ADHESIVO ADHESIVE BUTECH
45 cm x 120 cm	3	1,62	27,9	40	64,84	1115,76	Fr-one n / One-flex Premium
Perfil 1,5 cm x 45 cm	20	0,27	3,64	56	15,12	203,84	

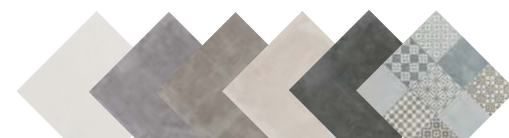

PAVIMENTO COMBINABLE: SERIE BOTTEGA 59,6 cm x 59,6 cm  
 FLOOR TILES COMBINATIONS: BOTTEGA SERIE 59,6 cm x 59,6 cm

\*valores aproximados. \*approximated values.

# MARBELLA

Revestimiento Monoporosa Rectificado / Rectified Wall Tiles



**MARBELLA BLUE**  
 45 cm x 120 cm x 1,04 cm P3580043 / 100214642 G274  
*Butech: Colorstuk Rapid n Manhattan B21522248/100236464*



**MARBELLA STONE**  
 45 cm x 120 cm x 1,04 cm P3580039 / 100214548 G274  
*Butech: Colorstuk Rapid n Gris B21522258/100236834*

MARBELLA ESTÁ FORMADA POR 3 DECORADOS DISTINTOS ALEATORIOS.  
 MARBELLA IS MADE IN 3 DIFFERENT RANDOM PATTERNS.

## EMBALAJE / PACKING

MODELO MODEL	PZ/CJ	M2/CJ	*KG/CJ	CJ/PAL	M2/PAL	*KG/PAL	ADHESIVO ADHESIVE BUTECH
Marbella 45 cm x 120 cm	3	1,62	28,18	40	64,84	1127,04	Fr-one n / One-flex Premium

\*valores aproximados. \*approximated values.





REV. / WALL TILE: MÉXICO CALIZA 45 cm x 120 cm \_PAV. / FLOOR TILE: MÉXICO CALIZA 59,6 cm x 59,6 cm

# MÉXICO ACAPULCO

Revestimiento Monoporosa Rectificado / Rectified Wall Tiles



## MÉXICO CALIZA

45 cm x 120 cm x 1,02 cm P3580054 / 100226476 G270

## PERFIL MÉXICO CALIZA

1,5 cm x 45 cm P3800027 / 100227218 G92

Butech: Colorstuk Rapid n Perla B21522263/100275760



## ACAPULCO CALIZA

45 cm x 120 cm x 0,96 cm P3580064 / 100229375 G274

Butech: Colorstuk Rapid n Perla B21522263/100275760



### EMBALAJE / PACKING

MODELO MODEL	PZ/CJ	M2/CJ	*KG/CJ	CJ/PAL	M2/PAL	*KG/PAL	ADHESIVO ADHESIVE BUTECH
45 cm x 120 cm	3	1,62	28,18	40	64,84	1127,04	Fr-one n / One-flex Premium
Perfil 1,5 cm x 45 cm	20	0,27	3,64	56	15,12	203,84	

\*valores aproximados. \*approximated values.

PAVIMENTO COMBINABLE- SERIE MÉXICO 59,6 x 59,6cm  
FLOOR TILES COMBINATIONS- MEXICO SERIE 59,6 x 59,6cm







REV. / WALL TILE: NANTES ACERO 45 cm x 120 cm, MEDICI NANTES ACERO 45 cm x 120 cm \_PAV. / FLOOR TILE: NANTES ACERO 120 cm x 120 cm

# NANTES MOSAICO NANTES MEDICI NANTES BOMBAY NANTES

Revestimiento Monoporosa Rectificado / Rectified Wall Tiles



**NANTES ACERO**  
 45 cm x 120 cm x 1 cm P3580081 / 100239857 G270  
**PERFIL NANTES ACERO**  
 1,5 cm x 45 cm P3800033 / 100240922 G92  
*Butech: Colorstuk Rapid n Gris B21522258/100236834*



**MOSAICO NANTES ACERO**  
 45 cm x 120 cm x 1,2 cm P3580082 / 100239860 G274  
*Butech: Colorstuk Rapid n Gris B21522258/100236834*



**MEDICI NANTES ACERO**  
 45 cm x 120 cm x 1,1 cm P3580071 / 100239854 G274  
*Butech: Colorstuk Rapid n Gris B21522258/100236834*



**BOMBAY NANTES**  
 45 cm x 120 cm x 1,03 cm P3580089 / 100240045 G274  
*Butech: Colorstuk Rapid n Manhattan B21522248/100236464*

BOMBAY NANTES ESTÁ FORMADA POR 3 DECORADOS DISTINTOS ALEATORIOS.  
 BOMBAY NANTES IS MADE IN 3 DIFFERENT RANDOM PATTERNS.

## EMBALAJE / PACKING

MODELO MODEL	PZ/CJ	M2/CJ	*KG/CJ	CJ/PAL	M2/PAL	*KG/PAL	ADHESIVO ADHESIVE BUTECH
45 cm x 120 cm	3	1,62	28,18	40	64,84	1127,04	Fr-one n / One-flex Premium
Perfil 1,5 cm x 45 cm	20	0,27	3,64	56	15,12	203,84	

\*valores aproximados. \*approximated values.

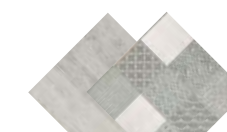

PAVIMENTO COMBINABLE: SERIE NANTES ACERO 59,6 cm x 59,6 cm  
 FLOOR TILES COMBINATIONS: NANTES ACERO SERIE 59,6 cm x 59,6 cm





REV. / WALL TILE: NANTES ARENA 45 cm x 120 cm, MEDICI NANTES ARENA 45 cm x 120 cm

# NANTES MOSAICO NANTES MEDICI NANTES BOMBAY NANTES

Revestimiento Monoporosa Rectificado / Rectified Wall Tiles



**NANTES ARENA**  
45 cm x 120 cm x 1 cm P3580087 / 100239872 G270  
**PERFIL NANTES ARENA**  
1,5 cm x 45 cm P3800030 / 100240902 G92  
*Butech: Colorstuk Rapid n Beige B21522252 /100236808*



**MOSAICO NANTES ARENA**  
45 cm x 120 cm x 1,2 cm P3580077 / 100239855 G274  
*Butech: Colorstuk Rapid n Beige B21522252 /100236808*



**MEDICI NANTES ARENA**  
45 cm x 120 cm x 1,1 cm P3580075 / 100239827 G274  
*Butech: Colorstuk Rapid n Beige B21522248 /100236464*



**BOMBAY NANTES**  
45 cm x 120 cm x 1,03 cm P3580089 / 100240045 G274  
*Butech: Colorstuk Rapid n Manhattan B21522248 /100236464*

BOMBAY NANTES ESTÁ FORMADA POR 3 DECORADOS DISTINTOS ALEATORIOS.  
BOMBAY NANTES IS MADE IN 3 DIFFERENT RANDOM PATTERNS.

## EMBALAJE / PACKING

MODELO MODEL	PZ/CJ	M2/CJ	*KG/CJ	CJ/PAL	M2/PAL	*KG/PAL	ADHESIVO ADHESIVE BUTECH
45 cm x 120 cm	3	1,62	28,18	40	64,84	1127,04	Fr-one n / One-flex Premium
Perfil 1,5 cm x 45 cm	20	0,27	3,64	56	15,12	203,84	

\*valores aproximados. \*approximated values.



PAVIMENTO COMBINABLE: SERIE NANTES ARENA 59,6 cm x 59,6 cm  
FLOOR TILES COMBINATIONS: NANTES ARENA SERIE 59,6 cm x 59,6 cm





REV. / WALL TILE: NANTES CALIZA 45 cm x 120 cm

# NANTES MOSAICO NANTES MEDICI NANTES BOMBAY NANTES

Revestimiento Monoporosa Rectificado / Rectified Wall Tiles



**NANTES CALIZA**  
 45 cm x 120 cm x 1 cm P3580069 / 100239844 G270  
**PERFIL NANTES CALIZA**  
 1,5 cm x 45 cm P38000341 / 100240923 G92  
*Butech: Colorstuk Rapid n Perla B21522263/100275760*



**MOSAICO NANTES CALIZA**  
 45 cm x 120 cm x 1,2 cm P3580086 / 100239861 G274  
*Butech: Colorstuk Rapid n Gris B21522258/100236834*



**MEDICI NANTES CALIZA**  
 45 cm x 120 cm x 1,1 cm P3580070 / 100239807 G274  
*Butech: Colorstuk Rapid n Perla B21522263/100275760*



**BOMBAY NANTES**  
 45 cm x 120 cm x 1,03cm P3580089 / 100240045 G274  
*Butech: Colorstuk Rapid n Manhattan B21522248/100236464*

BOMBAY NANTES ESTÁ FORMADA POR 3 DECORADOS DISTINTOS ALEATORIOS.  
 BOMBAY NANTES IS MADE IN 3 DIFFERENT RANDOM PATTERNS.

## EMBALAJE / PACKING

MODELO MODEL	PZ/CJ	M2/CJ	*KG/CJ	CJ/PAL	M2/PAL	*KG/PAL	ADHESIVO ADHESIVE BUTECH
45 cm x 120 cm	3	1,62	28,18	40	64,84	1127,04	Fr-one n / One-flex Premium
Perfil 1,5 cm x 45 cm	20	0,27	3,64	56	15,12	203,84	

\*valores aproximados. \*approximated values.



PAVIMENTO COMBINABLE: SERIE NANTES CALIZA 59,6 cm x 59,6 cm  
 FLOOR TILES COMBINATIONS: NANTES CALIZA SERIE 59,6 cm x 59,6 cm





REV. / WALL TILE: MOSAICO PRADA ACERO 45 cm x 120 cm \_PAV. / FLOOR TILE: PRADA ACERO 120 cm x 120 cm

# PRADA MOMBASA PRADA MOSAICO PRADA SPIGA PRADA

Revestimiento Monoporosa Rectificado / Rectified Wall Tiles



**PRADA ACERO**  
 45 cm x 120 cm x 1,02 cm P3580073 / 100239845 G270  
**PERFIL PRADA ACERO**  
 1,5 cm x 45 cm P3800032 / 100240924 G92  
*Butech: Colorstuk Rapid n Gris B21522258/100236834*

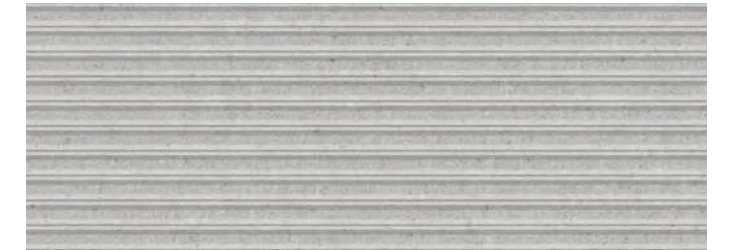

**MOMBASA PRADA ACERO**  
 45 cm x 120 cm x 1,15 cm P3580072 / 100239809 G274  
*Butech: Colorstuk Rapid n Gris B21522258/100236834*



**MOSAICO PRADA ACERO**  
 45 cm x 120 cm x 1,2 cm P3580068 / 100239829 G274  
*Butech: Colorstuk Rapid n Gris B21522258/100236834*

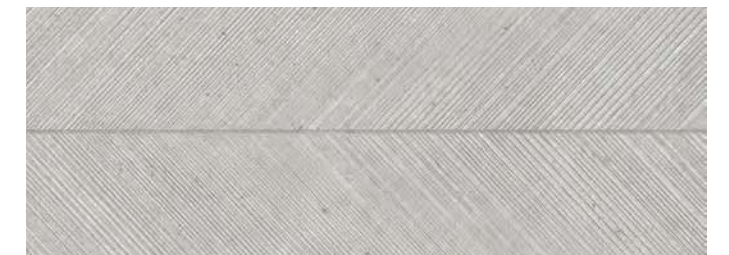

**SPIGA PRADA ACERO**  
 45 cm x 120 cm x 1 cm P3580083 / 100239874 G274  
*Butech: Colorstuk Rapid n Gris B21522258/100236834*

## EMBALAJE / PACKING

MODELO MODEL	PZ/CJ	M2/CJ	*KG/CJ	CJ/PAL	M2/PAL	*KG/PAL	ADHESIVO ADHESIVE BUTECH
45 cm x 120 cm	3	1,62	28,18	40	64,84	1127,04	Fr-one n / One-flex Premium
Perfil 1,5 cm x 45 cm	20	0,27	3,64	56	15,12	203,84	

\*valores aproximados. \*approximated values.



PAVIMENTO COMBINABLE: SERIE PRADA 59,6 cm x 59,6 cm  
 FLOOR TILES COMBINATIONS: PRADA SERIE 59,6 cm x 59,6 cm





REV. / WALL TILE: MOMBASA PRADA CALIZA 45 cm x 120 cm, PRADA CALIZA 45 cm x 120 cm

# PRADA MOMBASA PRADA MOSAICO PRADA SPIGA PRADA

Revestimiento Monoporosa Rectificado / Rectified Wall Tiles



**PRADA CALIZA**  
 45 cm x 120 cm x 1,02 cm P3580085 / 100239873 G270  
**PERFIL PRADA CALIZA**  
 1,5 cm x 45 cm P38000311 / 100240903 G92  
*Butech: Colorstuk Rapid n Marfil B21522257/100236794*



**MOMBASA PRADA CALIZA**  
 45 cm x 120 cm x 1,15 cm P3580078 / 100239841 G274  
*Butech: Colorstuk Rapid n Marfil B21522257/100236794*



**MOSAICO PRADA CALIZA**  
 45 cm x 120 cm x 1,2 cm P3580088 / 100239870 G274  
*Butech: Colorstuk Rapid n Marfil B21522257/100236794*



**SPIGA PRADA CALIZA**  
 45 cm x 120 cm x 1 cm P3580076 / 100239837 G274  
*Butech: Colorstuk Rapid n Marfil B21522257/100236794*

## EMBALAJE / PACKING

MODELO MODEL	PZ/CJ	M2/CJ	*KG/CJ	CJ/PAL	M2/PAL	*KG/PAL	ADHESIVO ADHESIVE BUTECH
45 cm x 120 cm	3	1,62	28,18	40	64,84	1127,04	Fr-one n / One-flex Premium
Perfil 1,5 cm x 45 cm	20	0,27	3,64	56	15,12	203,84	

\*valores aproximados. \*approximated values.



PAVIMENTO COMBINABLE: SERIE PRADA 59,6 cm x 59,6 cm  
 FLOOR TILES COMBINATIONS: PRADA SERIE 59,6 cm x 59,6 cm



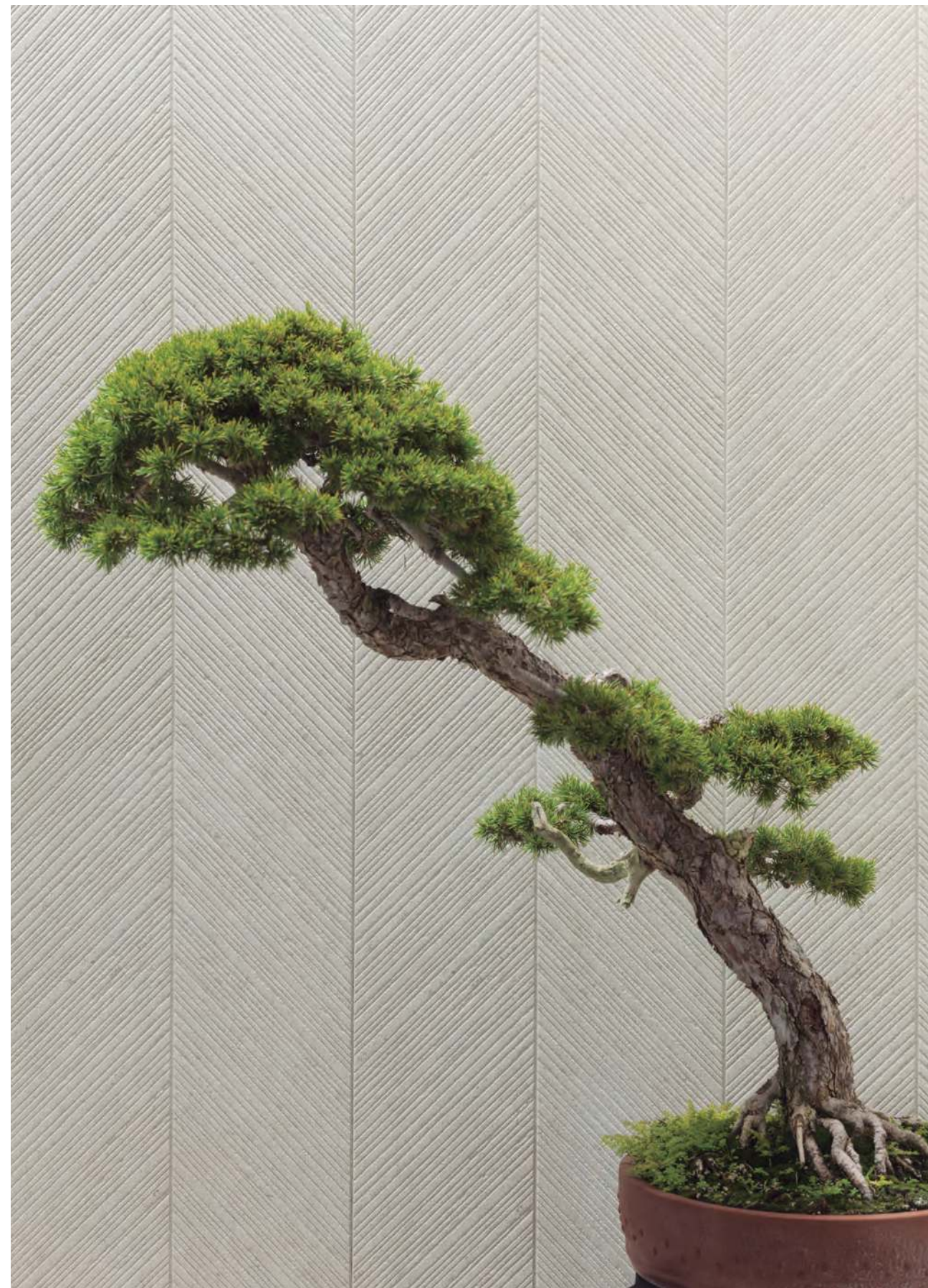

REV. / WALL TILE: SPIGA PRADA WHITE 45 cm x 120 cm

# PRADA MOMBASA PRADA MOSAICO PRADA SPIGA PRADA

Revestimiento Monoporosa Rectificado / Rectified Wall Tiles



**PRADA WHITE**  
 45 cm x 120 cm x 1,02 cm P3580093 / 100245262 G270  
**PERFIL PRADA CALIZA**  
 1,5 cm x 45 cm P3800039 / 100246454 G92  
*Butech: Colorstuk Rapid n Perla B21522263/100275760*



**MOMBASA PRADA WHITE**  
 45 cm x 120 cm x 1,15 cm P3580090 / 100245219 G274  
*Butech: Colorstuk Rapid n Gris B21522258/100236834*



**MOSAICO PRADA WHITE**  
 45 cm x 120 cm x 1,2 cm P3580091 / 100245233 G274  
*Butech: Colorstuk Rapid n Gris B21522258/100236834*



**SPIGA PRADA WHITE**  
 45 cm x 120 cm x 1 cm P3580092 / 100245263 G274  
*Butech: Colorstuk Rapid n Gris B21522258/100236834*

## EMBALAJE / PACKING

MODELO MODEL	PZ/CJ	M2/CJ	*KG/CJ	CJ/PAL	M2/PAL	*KG/PAL	ADHESIVO ADHESIVE BUTECH
45 cm x 120 cm	3	1,62	28,18	40	64,84	1127,04	Fr-one n / One-flex Premium
Perfil 1,5 cm x 45 cm	20	0,27	3,64	56	15,12	203,84	

\*valores aproximados. \*approximated values.

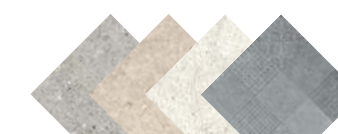

PAVIMENTO COMBINABLE: SERIE PRADA 59,6 cm x 59,6 cm  
 FLOOR TILES COMBINATIONS: PRADA SERIE 59,6 cm x 59,6 cm





REV. / WALL TILE: TOSCANA STONE 45 cm x 120 cm

# TOSCANA TOSCANA DECO

Revestimiento Monoporosa Rectificado / Rectified Wall Tiles



### TOSCANA STONE

45 cm x 120 cm x 1 cm P3580014 / 100190021 G270

### PERFIL TOSCANA STONE

1,5 cm x 45 cm P38000081 / 100190927 G92

Butech: Colorstuk Rapid n Beige B21522252/100236834



### TOSCANA CALIZA

45 cm x 120 cm x 1 cm P3580012 / 100190013 G270

### PERFIL TOSCANA CALIZA

1,5 cm x 45 cm P3800009 / 100190919 G92

Butech: Colorstuk Rapid n Beige B21522252/100236834



### TOSCANA BONE

45 cm x 120 cm x 1 cm P3580013 / 100190002 G270

### PERFIL TOSCANA BONE

1,5 cm x 45 cm P3800010 / 100190932 G92

Butech: Colorstuk Rapid n Beige B21522252/100236834



### TOSCANA DECO

45 cm x 120 cm x 1 cm P3580020 / 100200342 G274

Butech: Colorstuk Rapid n Beige B21522252/100236834

TOSCANA DECO ESTÁ FORMADA POR 4 DECORADOS DISTINTOS ALEATORIOS.  
TOSCANA DECO IS MADE IN 4 DIFFERENT RANDOM PATTERNS.

### EMBALAJE / PACKING

MODELO MODEL	PZ/CJ	M2/CJ	*KG/CJ	CJ/PAL	M2/PAL	*KG/PAL	ADHESIVO ADHESIVE BUTECH
45 cm x 120 cm	3	1,62	26,96	40	64,84	1078,41	Fr-one n / One-flex Premium
Perfil 1,5 cm x 45 cm	20	0,27	3,64	56	15,12	203,84	

\*valores aproximados. \*approximated values.



PAVIMENTO COMBINABLE: SERIE TOSCANA 59,6 cm x 59,6 cm  
FLOOR TILES COMBINATIONS: TOSCANA SERIE 59,6 cm x 59,6 cm



REV. / WALL TILE: MÁRMOL CARRARA BLANCO 45 cm x 120 cm \_PAV. / FLOOR TILE: CARRARA BLANCO BRILLO 59,6 cm x 59,6 cm

## MÁRMOL CARRARA BLANCO

Revestimiento Monoporosa Rectificado / Rectified Wall Tiles



### MÁRMOL CARRARA BLANCO XL

45 cm x 120 cm x 1,05 cm P3580015 / 100190191 G270

### PERFIL MÁRMOL CARRARA BLANCO XL

1,5 cm x 120 cm P3810007 / 100191575 G102

1,5 cm x 45 cm P3800011 / 100191585 G92

Butech: Colorstuk Rapid n Blanco B21522247/100236463

PAVIMENTO COMBINABLE: SERIE CARRARA BLANCO BRILLO 59,6 cm x 59,6 cm  
FLOOR TILES COMBINATIONS: CARRARA BLANCO GLOSS SERIE 59,6 cm x 59,6 cm

## TRAVERTINO MEDICI

Revestimiento Monoporosa Rectificado / Rectified Wall Tiles



### TRAVERTINO MEDICI

45 cm x 120 cm x 1 cm P3580016 / 100190496 G270

### PERFIL TRAVERTINO MEDICI

1,5 cm x 120 cm P3810008 / 100199487 G102

1,5 cm x 45 cm P3800012 / 100199488 G92

Butech: Colorstuk Rapid n Beige B21522252/100236808

PAVIMENTO COMBINABLE: SERIE TRAVERTINO MEDICI 59,6 cm x 59,6 cm  
FLOOR TILES COMBINATIONS: TRAVERTINO MEDICI SERIE 59,6 cm x 59,6 cm

### EMBALAJE / PACKING

MODELO MODEL	PZ/CJ	M2/CJ	*KG/CJ	CJ/PAL	M2/PAL	*KG/PAL	ADHESIVO ADHESIVE BUTECH
45 cm x 120 cm	3	1,62	30,05	40	64,84	1201,64	Fr-one n / One-flex Premium
Perfil 1,5 cm x 120 cm	15	0,54	7,42	28	15,12	207,65	
Perfil 1,5 cm x 45 cm	20	0,27	3,67	56	15,12	205,35	

\*valores aproximados. \*approximated values.





# MILANO

Revestimiento Monoporosa Rectificado / Rectified Wall Tiles



## MILANO TOPO

45 cm x 120 cm x 1,04 cm P3580041 / 100214645 G270

## PERFIL MILANO TOPO

1,5 cm x 45 cm P3800023 / 100219578 G92

1,5 cm x 120 cm P3810013 / 100220011 G102

Butech: Colorstuk Rapid n Manhattan B21522248/100236464

## EMBALAJE / PACKING

MODELO MODEL	PZ/CJ	M2/CJ	*KG/CJ	CJ/PAL	M2/PAL	*KG/PAL	ADHESIVO ADHESIVE BUTECH
45 cm x 120 cm	3	1,62	28,37	40	64,84	1134,96	Fr-one n / One-flex Premium
Perfil 1,5 cm x 120 cm	15	0,54	7,42	28	15,12	207,65	
Perfil 1,5 cm x 45 cm	20	0,27	3,67	56	15,12	205,35	

\*valores aproximados. \*approximated values.



PAVIMENTO COMBINABLE: SERIE MILANO 59,6 cm x 59,6 cm  
FLOOR TILES COMBINATIONS: MILANO SERIE 59,6 cm x 59,6 cm





REV. / WALL TILE: THASSOS 45 cm x 120 cm

## PERSIA

Revestimiento Monoporosa Rectificado / Rectified Wall Tiles



### PERSIA

45 cm x 120 cm x 1,03 cm P3580005 / 100179238 G270

### PERFIL PERSIA

,5 cm x 120 cm P3810004 / 100181299 G102

1,5 cm x 45 cm P3800001 / 100181322 G92

Butech: Colorstuk Rapid n Blanco B21522247/100236463

PAVIMENTO COMBINABLE: SERIE PERSIA 59,6 cm x 59,6 cm

FLOOR TILES COMBINATIONS: PERSIA SERIE 59,6 cm x 59,6 cm

## THASSOS

Revestimiento Monoporosa Rectificado / Rectified Wall Tiles



### THASSOS

45 cm x 120 cm x 1,05 cm P3580024 / 100202533 G270

### PERFIL THASSOS

1,5 cm x 45 cm P3800014 / 100203828 G92

1,5 cm x 120 cm P3810009 / 100203846 G102

Butech: Colorstuk Rapid n Perla B21522263/100275760

PAVIMENTO COMBINABLE: SERIE THASSOS 59,6 cm x 59,6 cm

FLOOR TILES COMBINATIONS: THASSOS SERIE 59,6 cm x 59,6 cm

### EMBALAJE / PACKING

MODELO MODEL	PZ/CJ	M2/CJ	*KG/CJ	CJ/PAL	M2/PAL	*KG/PAL	ADHESIVO ADHESIVE BUTECH
45 cm x 120 cm	3	1,62	29,82	40	64,84	1201,64	Fr-one n / One-flex Premium
Perfil 1,5 cm x 120 cm	15	0,54	7,42	28	15,12	207,65	
Perfil 1,5 cm x 45 cm	20	0,27	3,67	56	15,12	205,35	

\*valores aproximados. \*approximated values.



# MARMI BLANCO XL

Revestimiento Monoporosa Rectificado / Rectified Wall Tiles

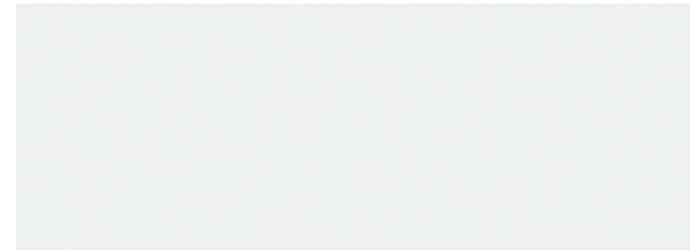

<b>MARMI BLANCO XL</b>		
45 cm x 120 cm x 1 cm	P3580006 / 100179329	G270
<b>PERFIL MARMI BLANCO XL</b>		
1,5 cm x 120 cm	P3810000 / 100181307	G102
1,5 cm x 45 cm	P3800000 / 100181309	G92
<i>Butech: Colorstuk Rapid n Blanco B21522247/100236463</i>		

## EMBALAJE / PACKING

MODELO MODEL	PZ/CJ	M2/CJ	*KG/CJ	CJ/PAL	M2/PAL	*KG/PAL	ADHESIVO ADHESIVE BUTECH
45 cm x 120 cm	3	1,62	29,61	40	64,84	1184,34	Fr-one n / One-flex Premium
Perfil 1,5 cm x 120 cm	15	0,54	7,42	28	15,12	207,65	
Perfil 1,5 cm x 45 cm	20	0,27	3,67	56	15,12	205,35	

\*valores aproximados. \*approximated values.

# MARMI CHINA XL SPIGA MARMI CHINA XL OXO DECO XL OXO LINE XL

Revestimiento Monoporosa Rectificado / Rectified Wall Tiles

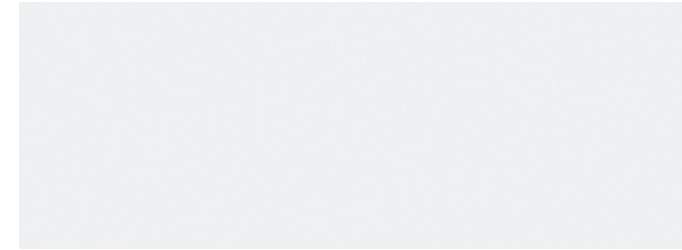

<b>MARMI CHINA XL</b>		
45 cm x 120 cm x 1 cm	P35800010 / 100179216	G270
<b>PERFIL MARMI CHINA XL</b>		
1,5 cm x 120 cm	P38100006 / 100181298	G102
1,5 cm x 45 cm	P38000005 / 100181330	G92
<i>Butech: Colorstuk Rapid n Blanco B21522247/100236463</i>		

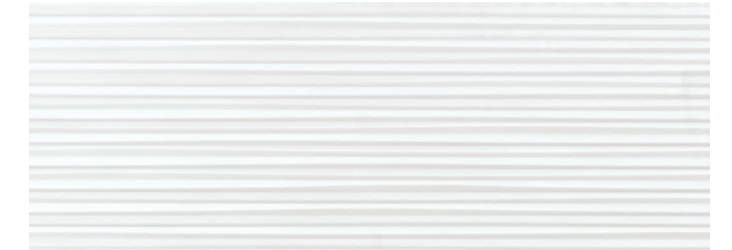

<b>SPIGA MARMI CHINA XL</b>		
45 cm x 120 cm x 1,1 cm	P3580106 / 100272228	G274
<i>Butech: Colorstuk Rapid n Blanco B21522247/100236463</i>		



**NEW**



<b>OXO DECO XL</b>		
45 cm x 120 cm x 1,1 cm	P35800008 / 100179255	G274
<i>Butech: Colorstuk Rapid n Blanco B21522247/100236463</i>		



<b>OXO LINE XL</b>		
45 cm x 120 cm x 1,1 cm	P35800009 / 100179351	G274
<i>Butech: Colorstuk Rapid n Blanco B21522247/100236463</i>		



## EMBALAJE / PACKING

MODELO MODEL	PZ/CJ	M2/CJ	*KG/CJ	CJ/PAL	M2/PAL	*KG/PAL	ADHESIVO ADHESIVE BUTECH
45 cm x 120 cm	3	1,62	29,61	40	64,84	1184,34	Fr-one n / One-flex Premium
Perfil 1,5 cm x 120 cm	15	0,54	7,42	28	15,12	207,65	
Perfil 1,5 cm x 45 cm	20	0,27	3,67	56	15,12	205,35	

\*valores aproximados. \*approximated values.





WHITES

REV. / WALL TILE: OXO DECO XL 45 cm x 120 cm, MARMI CHINA XL 45 cm x 120 cm \_PAV\_ FLOOR TILE: MANHATTAN COLONIAL 19,9 cm x 120 cm / 29,4 cm x 120 cm



# MATT MOSAICO MATT DECO MATT STRIPE MATT LINE MATT

Revestimiento Monoporosa Rectificado / Rectified Wall Tiles

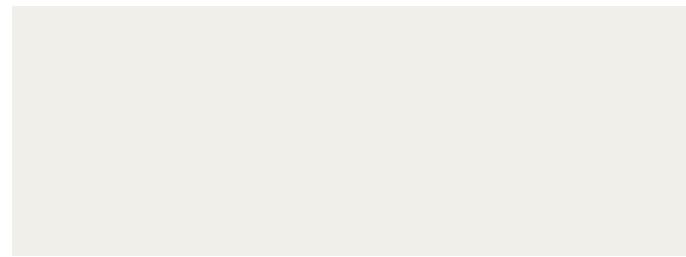

**MATT**  
 45 cm x 120 cm x 1 cm P3580074 / 100239853 G270  
**PERFIL MATT**  
 1,5 cm x 45 cm P3800036 / 100242144 G92  
 1,5 cm x 120 cm P3810024 / 100242132 G102  
*Butech: Colorstuk Rapid n Blanco B21522247/100236463*



**MOSAICO MATT**  
 45 cm x 120 cm x 1,2 cm P3580079 / 100239836 G274  
*Butech: Colorstuk Rapid n Blanco B21522247/100236463*



**DECO MATT**  
 45 cm x 120 cm x 1,03 cm P3580080 / 100239818 G274  
*Butech: Colorstuk Rapid n Blanco B21522247/100236463*

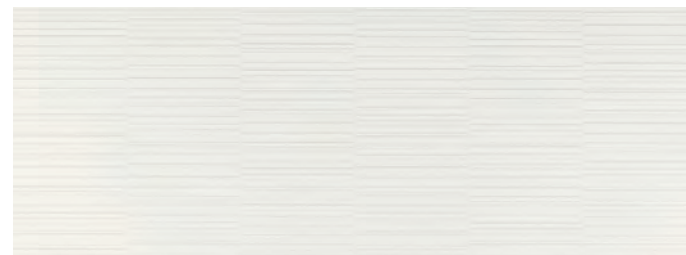

**STRIPE MATT**  
 45 cm x 120 cm x 1,08 cm P3580084 / 100239858 G274  
*Butech: Colorstuk Rapid n Blanco B21522247/100236463*

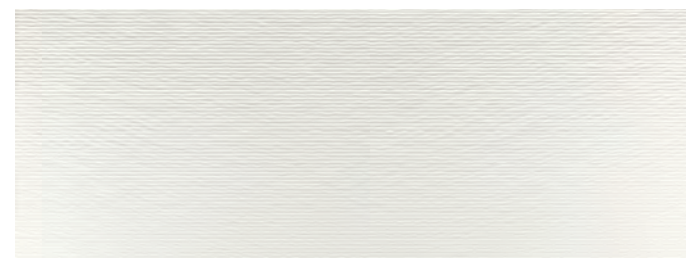

**LINE MATT**  
 45 cm x 120 cm x 1,07 cm P3580066 / 100239826 G274  
*Butech: Colorstuk Rapid n Blanco B21522247/100236463*



# DECO MATT CLUB MATT CLUB

Revestimiento Monoporosa Rectificado / Rectified Wall Tiles



**DECO MATT CLUB**  
 45 cm x 120 cm x 1,07 cm P3580107 / 100272125 G274  
*Butech: Colorstuk Rapid n Blanco B21522247/100236463*



**MATT CLUB**  
 45 cm x 120 cm x 1,07 cm P3580105 / 100272190 G274  
*Butech: Colorstuk Rapid n Blanco B21522247/100236463*



NEW

### EMBALAJE / PACKING

MODELO MODEL	PZ/CJ	M2/CJ	*KG/CJ	CJ/PAL	M2/PAL	*KG/PAL	ADHESIVO ADHESIVE BUTECH
45 cm x 120 cm	3	1,62	29,12	40	64,84	1164,96	Fr-one n / One-flex Premium
Perfil 1,5 cm x 120 cm	15	0,54	7,42	28	15,12	207,65	
Perfil 1,5 cm x 45 cm	20	0,27	3,64	56	15,12	203,84	

\*valores aproximados. \*approximated values.

PAVIMENTO COMBINABLE: SERIE MATT 59,6 cm x 59,6 cm  
 FLOOR TILES COMBINATIONS: MATT SERIE 59,6 cm x 59,6 cm





REV. / WALL TILE: CAPRI STONE 45 cm x 120 cm \_PAV. / FLOOR TILE: MANHATTAN COLONIAL 29,4 cm x 180 cm / 19,3 cm x 180 cm

# CAPRI CAPRI LINEAL

Revestimiento Monoporosa Rectificado / Rectified Wall Tiles



**CAPRI BONE**  
 45 cm x 120 cm x 1 cm P3580021 / 100202526 G270  
**PERFIL CAPRI BONE**  
 1,5 cm x 45 cm P3800013 / 100203814 G92  
*Butech: Colorstuk Rapid n Perla B21522263/100275760*



**CAPRI STONE**  
 45 cm x 120 cm x 1 cm P3580029 / 100202546 G270  
**PERFIL CAPRI STONE**  
 1,5 cm x 45 cm P3800016 / 100203815 G92  
*Butech: Colorstuk Rapid n Beige B21522252/100236808*



**CAPRI LINEAL BONE**  
 45 cm x 120 cm x 1,2 cm P3580025 / 100202545 G274  
*Butech: Colorstuk Rapid n Perla B21522263/100275760*



**CAPRI LINEAL STONE**  
 45 cm x 120 cm x 1,2 cm P3580030 / 100202571 G274  
*Butech: Colorstuk Rapid n Beige B21522252/100236808*

## EMBALAJE / PACKING

MODELO MODEL	PZ/CJ	M2/CJ	*KG/CJ	CJ/PAL	M2/PAL	*KG/PAL	ADHESIVO ADHESIVE BUTECH
45 cm x 120 cm	3	1,62	26,96	40	64,84	1078,41	Fr-one n / One-flex Premium
Perfil 1,5 cm x 45 cm	20	0,27	3,67	56	15,12	205,34	

\*valores aproximados. \*approximated values.





# COLUMBIA

Revestimiento Monoporosa Rectificado / Rectified Wall Tiles



## COLUMBIA SILVER

45 cm x 120 cm x 1 cm P3580032 / 100202862 G296

Butech: Colorstuk Rapid n Antracita B21522250/100236481

ADHESIVO RECOMENDADO - RECOMMENDED ADHESIVE - Fr-one n  
 ÁMBITO DE USO - FIELD OF USE - Revestimiento de paredes interiores - Interior wall covering.

ATENCIÓN: PRODUCTO ESPECIAL  
 La manipulación indebida durante la colocación y rejuntado, puede causar rayados y rozaduras de los que PORCELANOSA S.A. no se hace responsable - No utilizar para la retirada de material de rejuntado y la limpieza del producto agentes abrasivos - Evitar contactos prolongados de la superficie decorada con ácidos y álcalis - Se recomienda usar como agentes de limpieza únicamente agua y jabón neutro - Al tratarse de un material delicado, su manipulación ha de ser cuidadosa. Adoptar métodos de colocación específicos del tipo de material (utilizar adhesivos y material de rejuntado apropiados) - Evitar, durante la instalación, el uso de utensilios que puedan dañar el material cerámico - Utilizar técnica de doble encolado (aplicando material de agarre en la pieza y el soporte a embaldosar) para evitar las indeseables zonas vacías - No prolongar en exceso el secado del material de rejuntado en la superficie - Para el corte de las piezas, utilizar cortadoras e ingleteadoras eléctricas con disco refrigerado con agua.

WARNING: SPECIALS PRODUCTS  
 Improper manipulation during fixing and grouting can cause scratches for which PORCELANOSA S.A. will not take responsibility - Do not use abrasive agents to clean this product - Avoid long contact of the decorated surface with acids and alkalis - Use only hot water and mild soap as cleaning agents - This is a delicate material that must be handled with care. Use specific installation methods (use the proper bonding material) - Do not use tools that could damage material during installation - Use the floating and buttering method, applying the bonding material to both the back of the piece and the substrate, so as to ensure that there are no unwanted voids - Grouting material should not be left to dry for a too long time in the surface - To cut pieces, use electric water-cooled cutters and mitring saw.

## EMBALAJE / PACKING

MODELO MODEL	PZ/CJ	M2/CJ	*KG/CJ	CJ/PAL	M2/PAL	*KG/PAL	ADHESIVO ADHESIVE BUTECH
45 cm x 120 cm	3	1,62	26,93	32	51,84	861,79	Fr-one n / One-flex Premium

\*valores aproximados. \*approximated values.





REV. / WALL TILE: LEXINGTON MAPLE 45 cm x 120 cm \_PAV. / FLOOR TILE: MANHATTAN MAPLE 19,3 cm x 180 cm / 29,4 cm x 180 cm

# LEXINGTON

Revestimiento Monoporosa Rectificado / Rectified Wall Tiles



## LEXINGTON COLONIAL

45 cm x 120 cm x 1,05 cm P3580028 / 100202573 G274

Butech: Colorstuk Rapid n Manhattan B21522248/100236464



## LEXINGTON MAPLE

45 cm x 120 cm x 1,05 cm P3580023 / 100202532 G274

Butech: Colorstuk Rapid n Beige B21522252/100236808



## LEXINGTON COGNAC

45 cm x 120 cm x 1,05 cm P3580027 / 100202572 G274

Butech: Colorstuk Rapid n Tabaco B21522255/100236823

### EMBALAJE / PACKING

MODELO MODEL	PZ/CJ	M2/CJ	*KG/CJ	CJ/PAL	M2/PAL	*KG/PAL	ADHESIVO ADHESIVE BUTECH
45 cm x 120 cm	3	1,62	27,63	40	64,84	1105,23	Fr-one n / One-flex Premium

\*valores aproximados. \*approximated values.





REV. / WALL TILE: LISTÓN MADERA ROBLE 45 cm x 120cm \_PAV. / FLOOR TILE: BOTTEGA CALIZA 59,6 cm x 59,6cm

# LISTÓN MADERA

Revestimiento Monoporosa Rectificado / Rectified Wall Tiles



## LISTÓN MADERA ROBLE

45 cm x 120 cm x 1,03 cm P3580042 / 100214620 G274

Butech: Colorstuk Rapid n Tabaco B21522255/100236823

### EMBALAJE / PACKING

MODELO MODEL	PZ/CJ	M2/CJ	*KG/CJ	CJ/PAL	M2/PAL	*KG/PAL	ADHESIVO ADHESIVE BUTECH
45 cm x 120 cm	3	1,62	27,80	40	64,84	1112,04	Fr-one n / One-flex Premium

\*valores aproximados. \*approximated values.





REV. / WALL TILE: SPIGA TOPO 45 cm x 120 cm

# SPIGA

Revestimiento Monoporosa Rectificado / Rectified Wall Tiles



## SPIGA TOPO

45 cm x 120 cm x 1 cm P3580001 / 100179363 G274

Butech: Colorstuk Rapid n Blanco B2152224/100236463

## EMBALAJE / PACKING

MODELO MODEL	PZ/CJ	M2/CJ	*KG/CJ	CJ/PAL	M2/PAL	*KG/PAL	ADHESIVO ADHESIVE BUTECH
45 cm x 120 cm	3	1,62	28,25	40	64,84	1130,07	Fr-one n / One-flex Premium

\*valores aproximados. \*approximated values.



# NO

Revestimientos rectificados que recrean superficies infinitas donde las uniones entre las piezas hábilmente se desvanecen creando una envoltura prácticamente continua.

## REVESTI- MIENTO RECTIFI- CADO

*Rectified coverings wich recreate infinite surfaces where the joints between the tiles usually fade, creating a covering that is practically continuous.*

## RECTI- FIED WALL TILES



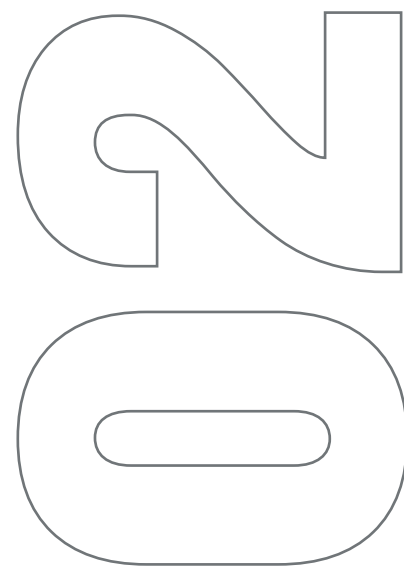

## STONES &amp; CONCRETES

DECO BOSTON _ BOSTON	73
MARBELLA _ BOTTEGA	75
DOVER ANTIQUE _ BELICE _ DOVER SPIGA _ DOVER MODERN LINE _ DOVER	77
DECO DURANGO _ SPIGA DURANGO _ MOSAICO DURANGO _ DURANGO	81
HARLEM	83
ANTIQUE _ PARK LINEAL _ PARK	85
MOSAICO RODANO _ RODANO	86

NEW

## MARBLES

BARI	91
CALACATA	93
MOSAICO CARRARA BLANCO _ MÁRMOL CARRARA BLANCO	95
OLIMPO	97
MOSAICO RECIFE _ RECIFE	99
SENA	101

## WHITES

JERSEY _ BALI	103
BARBADOS TOPO _ BARBADOS	105
LINO BLANCO _ GLASS BLANCO	107
OXO LINE _ OXO DECO _ MARMÍ CHINA	109
MARMÍ DECO BLANCO _ MARMÍ BLANCO	111
MENORCA HOJA _ MENORCA LINE _ MENORCA BLANCO	113
QATAR NÁCAR _ SEÚL NÁCAR	115
RETRO STUDIO _ MOSAICO STUDIO _ DECO STUDIO _ STUDIO	117

## TEXTURES

BRUNEI	120
JAPAN	121
TACO OXFORD _ LISTON OXFORD	123
MADISON	125
SAFARI	126
YAKARTA	127



# BOSTON DECO BOSTON

Revestimiento Monoporosa Rectificado / Wall Tiles Rectified



### BOSTON TOPO

31,6 cm x 90 cm x 0,93 cm P3470845 / 100179290 G261

### PERFIL BOSTON TOPO

1,5 cm x 31,6 cm P6209126 / 100180393 G77

Butech: Colorstuk Rapid n Gris B21522258/100236834



### DECO BOSTON TOPO

31,6 cm x 90 cm x 1,13 cm P3470842 / 100179267 G271

Butech: Colorstuk Rapid n Gris B21522258/100236834



### EMBALAJE / PACKING

MODELO MODEL	PZ/CJ	M2/CJ	*KG/CJ	CJ/PAL	M2/PAL	*KG/PAL	ADHESIVO ADHESIVE BUTECH
31,6 cm x 90 cm	4	1,14	18,97	57	64,84	1081,44	Fr-one n / One-flex Premium
Deco 31,6 cm x 90 cm	3	0,85	15,27	66	56,31	1007,88	
Perfil 1,5 cm x 45 cm	30	0,28	3,83	42	11,94	160,93	

\*valores aproximados. \*approximated values.



PAVIMENTO COMBINABLE: SERIE BOSTON 43,5 cm x 65,9 cm  
FLOOR TILES COMBINATIONS: BOSTON SERIE 43,5 cm x 65,9 cm





REV. / WALL TILE: MARBELLA STONE 31,6 cm x 90 cm

## BOTTEGA MARBELLA

Revestimiento Monoporosa Rectificado / Wall Tiles Rectified



### BOTTEGA CALIZA

31,6 cm x 90 x 0,90 cm P3470877 / 100215126 G261

### PERFIL BOTTEGA CALIZA

1,5 cm x 31,6 cm P6209138 / 100222555 G77

Butech: Colorstuk Rapid n Gris B21522258/100236834

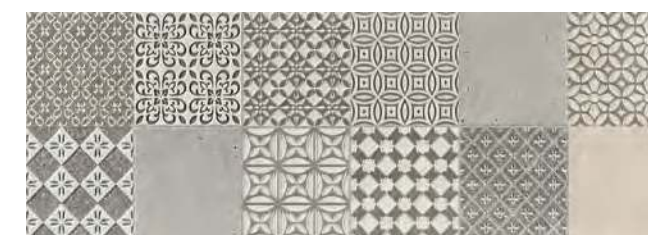

### MARBELLA STONE

31,6 cm x 90 cm x 0,90 cm P3470884 / 100215171 G271

Butech: Colorstuk Rapid n Gris B21522258/100236834



MARBELLA ESTÁ FORMADA POR 6 DECORADOS DISTINTOS ALEATORIOS.  
MARBELLA IS MADE IN 6 DIFFERENT RANDOM PATTERNS.

### EMBALAJE / PACKING

MODELO MODEL	PZ/CJ	M2/CJ	*KG/CJ	CJ/PAL	M2/PAL	*KG/PAL	ADHESIVO ADHESIVE BUTECH
31,6 cm x 90 cm	4	1,13	18,82	57	64,84	1078,41	Fr-one n / One-flex Premium
Perfil 1,5 cm x 31,6 cm	30	0,28	3,84	42	11,94	161,28	

\*valores aproximados. \*approximated values.

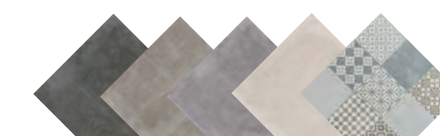

PAVIMENTO COMBINABLE: SERIE BOTTEGA 59,6 cm x 59,6 cm  
FLOOR TILES COMBINATIONS: BOTTEGA SERIE 59,6 cm x 59,6 cm





REV. / WALL TILE: DOVER ACERO 31,6 cm x 90 cm, DOVER SPIGA ACERO 31,6 cm x 90 cm \_PAV. / FLOOR TILE: DOVER ACERO 59,6 cm x 59,6 cm

# DOVER DOVER MODERN LINE DOVER ANTIQUE BELICE

Revestimiento Monoporosa Rectificado / Wall Tiles Rectified



### DOVER ACERO

31,6 cm x 90 cm x 0,9 cm P3470759 / 100155567 G261

### PERFIL DOVER ACERO

1,5 cm x 31,6 cm P6209109 / 100156682 G77

Butech: Colorstuk Rapid n Gris B21522258/100236834



### DOVER MODERN LINE ACERO

31,6 cm x 90 cm x 1,14 cm P3470761 / 100155622 G271

Butech: Colorstuk Rapid n Gris B21522258/100236834



### DOVER ANTIQUE

31,6 cm x 90 cm x 0,9 cm P3470757 / 100155610 G271

Butech: Colorstuk Rapid n Cemento B21522249/100236449



### BELICE ACERO

31,6 cm x 90 cm x 0,91 cm P3470745 / 100155581 G271

Butech: Colorstuk Rapid n Gris B21522258/100236834

SERIE DOVER ANTIQUE ESTÁ FORMADA POR 6 DECORADOS DISTINTOS ALEATORIOS.  
DOVER ANTIQUE SERIE IS MADE IN 6 DIFFERENT RANDOM PATTERNS.

### EMBALAJE / PACKING

MODELO MODEL	PZ/CJ	M2/CJ	*KG/CJ	CJ/PAL	M2/PAL	*KG/PAL	ADHESIVO ADHESIVE BUTECH
31,6 cm x 90 cm	4	1,14	18,97	57	64,84	1081,44	Fr-one n / One-flex Premium
Modern Line 31,6 cm x 90 cm	3	0,85	14,69	57	48,63	837,14	
Perfil 1,5 cm x 31,6 cm	30	0,28	3,83	42	11,94	160,93	

\*valores aproximados. \*approximated values.



PAVIMENTO COMBINABLE: SERIE DOVER 59,6 cm x 59,6 cm  
FLOOR TILES COMBINATIONS: DOVER SERIE 59,6 cm x 59,6 cm



# DOVER DOVER MODERN LINE DOVER ANTIQUE

Revestimiento Monoporosa Rectificado / Wall Tiles Rectified

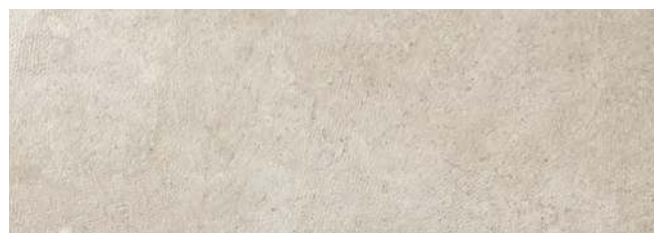

**DOVER ARENA**  
 31,6 cm x 90 cm x 0,9 cm P3470756 / 100155613 G261  
**PERFIL DOVER ARENA**  
 1,5 cm x 31,6 cm P6209110 / 100156683 G77  
*Butech: Colorstuk Rapid n Gris B21522258/100236834*

**DOVER MODERN LINE ARENA**  
 31,6 cm x 90 cm x 1,14 cm P3470762 / 100155623 G271  
*Butech: Colorstuk Rapid n Gris B21522258/100236834*



**DOVER ANTIQUE**  
 31,6 cm x 90 cm x 0,9cm P3470757 / 100155610 G271  
*Butech: Colorstuk Rapid n Cemento B21522249/100236449*

SERIE DOVER ANTIQUE ESTÁ FORMADA POR 6 DECORADOS DISTINTOS ALEATORIOS.  
 DOVER ANTIQUE SERIE IS MADE IN 6 DIFFERENT RANDOM PATTERNS.

## EMBALAJE / PACKING

MODELO MODEL	PZ/CJ	M2/CJ	*KG/CJ	CJ/PAL	M2/PAL	*KG/PAL	ADHESIVO ADHESIVE BUTECH
31,6 cm x 90 cm	4	1,14	18,97	57	64,84	1081,44	Fr-one n / One-flex Premium
Modern Line 31,6 cm x 90 cm	3	0,85	14,69	57	48,63	837,14	
Perfil 1,5 cm x 31,6 cm	30	0,28	3,83	42	11,94	160,93	

\*valores aproximados. \*approximated values.



PAVIMENTO COMBINABLE: SERIE DOVER 59,6 cm x 59,6 cm  
 FLOOR TILES COMBINATIONS: DOVER SERIE 59,6 cm x 59,6 cm

# DOVER DOVER MODERN LINE DOVER SPIGA BELICE DOVER ANTIQUE

Revestimiento Monoporosa Rectificado / Wall Tiles Rectified

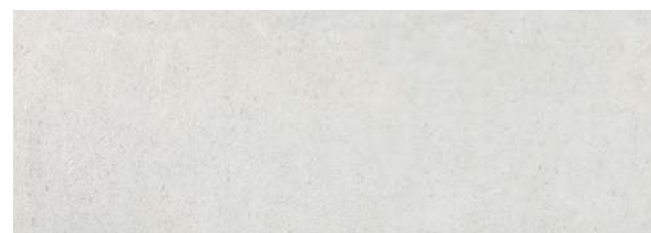

**DOVER CALIZA**  
 31,6 cm x 90 cm x 0,9 cm P3470758 / 100155616 G261  
**PERFIL DOVER CALIZA**  
 1,5 cm x 31,6 cm P6209108 / 100156684 G77  
*Butech: Colorstuk Rapid n Gris B21522258/100236834*

**DOVER MODERN LINE CALIZA**  
 31,6 cm x 90 cm x 1,14 cm P3470760 / 100155624 G271  
*Butech: Colorstuk Rapid n Gris B21522258/100236834*



**DOVER SPIGA CALIZA**  
 31,6 cm x 90 cm x 1,04 cm P3470770 / 100155975 G271  
*Butech: Colorstuk Rapid n Gris B21522258/100236834*

**BELICE CALIZA**  
 31,6 cm x 90 cm x 0,91 cm P3470752 / 100155582 G271  
*Butech: Colorstuk Rapid n Gris B21522258/100236834*



PAVIMENTO COMBINABLE: SERIE DOVER 59,6 cm x 59,6 cm  
 FLOOR TILES COMBINATIONS: DOVER SERIE 59,6 cm x 59,6 cm

**DOVER ANTIQUE**  
 31,6 cm x 90 cm x 0,9 cm P3470757 / 100155610 G271  
*Butech: Colorstuk Rapid n Cemento B21522249/100236449*

SERIE DOVER ANTIQUE ESTÁ FORMADA POR 6 DECORADOS DISTINTOS ALEATORIOS.  
 DOVER ANTIQUE SERIE IS MADE IN 6 DIFFERENT RANDOM PATTERNS.

## EMBALAJE / PACKING

MODELO MODEL	PZ/CJ	M2/CJ	*KG/CJ	CJ/PAL	M2/PAL	*KG/PAL	ADHESIVO ADHESIVE BUTECH
31,6 cm x 90 cm	4	1,14	19,58	57	64,84	1081,44	Fr-one n / One-flex Premium
Modern Line 31,6 cm x 90 cm	3	0,85	14,69	57	48,63	837,14	
Spiiga 31,6 cm x 90 cm	3	0,85	13,29	66	56,31	876,74	
Perfil 1,5 cm x 31,6 cm	30	0,28	3,83	42	11,94	160,93	

\*valores aproximados. \*approximated values.





# DURANGO MOSAICO DURANGO SPIGA DURANGO DECO DURANGO

Revestimiento Monoporosa Rectificado / Wall Tiles Rectified



NEW



**DURANGO ACERO**  
31,6 cm x 90 cm x 0,9 cm P3470913 / 100272111 G261  
**PERFIL DURANGO ACERO**  
1,5 cm x 31,6 cm P6209145 / 100274473 G77  
Butech: Colorstuk Rapid n Gris B21522258/10027211



**DURANGO BONE**  
31,6 cm x 90 cm x 0,9 cm P3470911 / 100272181 G261  
**PERFIL DURANGO BONE**  
1,5 cm x 31,6 cm P6209144 / 100274439 G77  
Butech: Colorstuk Rapid n Gris B21522258/10027211



**MOSAICO DURANGO**  
31,6 cm x 90 cm x 0,9 cm P3470912 / 100272174 G271  
Butech: Colorstuk Rapid n Gris B21522258/10027211



**SPIGA DURANGO**  
31,6 cm x 90 cm x 0,9 cm P3470915 / 100272208 G271  
Butech: Colorstuk Rapid n Gris B21522258/10027211



**DECO DURANGO**  
31,6 cm x 90 cm x 0,9 cm P3470914 / 100272150 G271  
Butech: Colorstuk Rapid n Cemento B21522249/100236449



PAVIMENTO COMBINABLE: SERIE DURANGO 59,6 cm x 59,6 cm  
FLOOR TILES COMBINATIONS: DURANGO SERIE 59,6 cm x 59,6 cm

SERIE DECO DURANGO ESTÁ FORMADA POR 6 DECORADOS DISTINTOS ALEATORIOS.  
DECO DURANGO SERIE IS MADE IN 6 DIFFERENT RANDOM PATTERNS.

## EMBALAJE / PACKING

MODELO MODEL	PZ/CJ	M2/CJ	*KG/CJ	CJ/PAL	M2/PAL	*KG/PAL	ADHESIVO ADHESIVE BUTECH
31,6 cm x 90 cm	4	1,14	18,97	57	64,84	1081,44	Fr-one n / One-flex Premium
Mosaico/Spiга 31,6 cm x 90 cm	4	1,14	19,64	51	58,02	1001,44	
Deco 31,6 cm x 90 cm	4	1,14	20,70	57	64,84	1180,13	
Perfil 1,5 cm x 31,6 cm	30	30	3,84	42	11,94	161,28	

\*valores aproximados. \*approximated values.





REV. / WALL TILE: HARLEM CALIZA 31,6 cm x 90 cm \_PAV. / FLOOR TILE: HARLEM CALIZA 59,6 cm x 59,6 cm, DECO HARLEM CALIZA 59,6 cm x 59,6 cm

## HARLEM

Revestimiento Monoporosa Rectificado / Wall Tiles Rectified



### HARLEM ACERO

31,6 cm x 90 cm x 0,9 cm P3470785 / 100161060 G261

### PERFIL HARLEM ACERO

1,5 cm x 31,6 cm P6209117 / 100161451 G77

Butech: Colorstuk Rapid n Manhattan B21522248/100236464



### HARLEM CALIZA

31,6 cm x 90 cm x 0,9 cm P3470783 / 100161061 G261

### PERFIL HARLEM CALIZA

1,5 cm x 31,6 cm P6209114 / 100161431 G77

Butech: Colorstuk Rapid n Marfil B21522257/100236794

### EMBALAJE / PACKING

MODELO MODEL	PZ/CJ	M2/CJ	*KG/CJ	CJ/PAL	M2/PAL	*KG/PAL	ADHESIVO ADHESIVE BUTECH
31,6 cm x 90 cm	4	1,14	19,09	57	64,84	1088,01	Fr-one n / One-flex Premium
Perfil 1,5 cm x 31,6 cm	30	0,26	3,83	42	11,94	160,93	

\*valores aproximados. \*approximated values.



PAVIMENTO COMBINABLE: SERIE HARLEM 59,6 cm x 59,6 cm  
FLOOR TILES COMBINATIONS: HARLEM SERIE 59,6 cm x 59,6 cm





REV. / WALL TILE: PARK ACERO 31,6 cm x 90 cm, PARK LINEAL ACERO 31,6 cm x 90 cm \_PAV. / FLOOR TILE: PARK ACERO 59,6 cm x 59,6 cm

## PARK PARK LINEAL ANTIQUE

Revestimiento Monoporosa Rectificado / Wall Tiles Rectified



**PARK ACERO**  
31,6 cm x 90 cm x 0,9 cm P3470729 / 100145725 G261  
**PERFIL PARK ACERO**  
1,5 cm x 31,6 cm P6209106 / 100147025 G77  
*Butech: Colorstuk Rapid n Manhattan B21522248/100236464*



**PARK LINEAL ACERO**  
31,6 cm x 90 x 0,95 cm P3470726 / 100145729 G271  
*Butech: Colorstuk Rapid n Manhattan B21522248/100236464*



**ANTIQUE BLUE**  
31,6 cm x 90 cm x 0,9 cm P3470727 / 100145532 G271  
*Butech: Colorstuk Rapid n Cemento B21522249/100236449*



**ANTIQUE GREY**  
31,6 cm x 90 cm x 0,9 cm P3470734 / 100146609 G271  
*Butech: Colorstuk Rapid n Cemento B21522249/100236449*

SERIE ANTIQUE ESTÁ FORMADA POR 4 DECORADOS DISTINTOS ALEATORIOS.  
ANTIQUÉ SERIE IS MADE IN 4 DIFFERENT RANDOM PATTERNS.

### EMBALAJE / PACKING

MODELO MODEL	PZ/CJ	M2/CJ	*KG/CJ	CJ/PAL	M2/PAL	*KG/PAL	ADHESIVO ADHESIVE BUTECH
31,6 cm x 90 cm	4	1,14	18,17	57	64,84	1071	Fr-one n / One-flex Premium
Perfil 1,5 cm x 31,6 cm	30	0,28	3,72	42	11,94	156,24	

\*valores aproximados. \*approximated values.



PAVIMENTO COMBINABLE: SERIE HARLEM 59,6 cm x 59,6 cm  
FLOOR TILES COMBINATIONS: HARLEM SERIE 59,6 cm x 59,6 cm



# RODANO MOSAICO RODANO

Revestimiento Monoporosa Rectificado / Wall Tiles Rectified



**RODANO ACERO**  
31,6 cm x 90 cm x 0,9 cm P3470631 / 100120789 G261

**PERFIL RODANO ACERO**  
1,5 cm x 31,6 cm P6209077 / 100126424 G77

Butech: Colorstuk Rapid n Manhattan B21522248/100236464



**MOSAICO RODANO ACERO**  
31,6 cm x 90 cm x 1,13 cm P3470624 / 100120782 G271

Butech: Colorstuk Rapid n Manhattan B21522248/100236464

## EMBALAJE / PACKING

MODELO MODEL	PZ/CJ	M2/CJ	*KG/CJ	CJ/PAL	M2/PAL	*KG/PAL	ADHESIVO ADHESIVE BUTECH
31,6 cm x 90 cm	4	1,14	18,97	57	64,84	1081,44	Fr-one n / One-flex Premium
Mosaico 31,6 cm x 90 cm	3	0,85	14,74	57	56,31	972,79	
Perfil 1,5 cm x 31,6 cm	30	0,28	3,83	42	11,94	160,93	

\*valores aproximados. \*approximated values.



PAVIMENTO COMBINABLE: SERIE RODANO 59,6 cm x 59,6 cm  
FLOOR TILES COMBINATIONS: RODANO SERIE 59,6 cm x 59,6 cm

# RODANO MOSAICO RODANO

Revestimiento Monoporosa Rectificado / Wall Tiles Rectified



**RODANO CALIZA**  
31,6 cm x 90 cm x 0,9 cm P3470632 / 100120795 G261

**PERFIL RODANO CALIZA**  
1,5 cm x 31,6 cm P6209079 / 100126428 G77

Butech: Colorstuk Rapid n Gris B21522258/100236834



**MOSAICO RODANO CALIZA**  
31,6 cm x 90 cm x 1 cm P3470626 / 100120784 G271

Butech: Colorstuk Rapid n Gris B21522258/100236834



**RODANO SILVER**  
31,6 cm x 90 cm x 0,9 cm P3470633 / 100120798 G261

**PERFIL RODANO SILVER**  
1,5 cm x 31,6 cm P6209076 / 100126425 G77

Butech: Colorstuk Rapid n Cemento B21522249/100236449



**MOSAICO RODANO SILVER**  
31,6 cm x 90 cm x 1 cm P3470625 / 100120785 G271

Butech: Colorstuk Rapid n Cemento B21522249/100236449

## EMBALAJE / PACKING

MODELO MODEL	PZ/CJ	M2/CJ	*KG/CJ	CJ/PAL	M2/PAL	*KG/PAL	ADHESIVO ADHESIVE BUTECH
31,6 cm x 90 cm	4	1,14	18,97	57	64,84	1081,44	Fr-one n / One-flex Premium
Mosaico 31,6 cm x 90 cm	3	0,85	14,74	57	56,31	972,79	
Perfil 1,5 cm x 31,6 cm	30	0,28	3,83	42	11,94	160,93	

\*valores aproximados. \*approximated values.



PAVIMENTO COMBINABLE: SERIE RODANO 59,6 cm x 59,6 cm  
FLOOR TILES COMBINATIONS: RODANO SERIE 59,6 cm x 59,6 cm





TONES & CONCRETES

REV. / WALL TILE: RODANO ACERO 31,6 cm x 90 cm, MOSAICO RODANO ACERO 31,6 cm x 90 cm





REV. / WALL TILE: BARI BLANCO 31,6 cm x 90 cm\_PAV. / FLOOR TILE: BARI BLANCO 59,6 cm x 59,6 cm

# BARI

Revestimiento Monoporosa Rectificado / Wall Tiles Rectified



**BARI BLANCO**

31,6 cm x 90 cm x 0,9 cm P3470763 / 100155617 G261

**PERFIL BARI BLANCO**

1,5 cm x 31,6 cm P6209112 / 100156686 G77

1,5 cm x 90 cm P6560267 / 100156687 G97

*Butech: Colorstuk Rapid n Perla B21522263/100275760*

**EMBALAJE / PACKING**

MODELO MODEL	PZ/CJ	M2/CJ	*KG/CJ	CJ/PAL	M2/PAL	*KG/PAL	ADHESIVO ADHESIVE BUTECH
31,6 cm x 90 cm	4	1,14	19,3	57	64,84	1081,44	Fr-one n / One-flex Premium
Perfil 1,5 cm x 31,6 cm	30	0,36	3,83	42	11,94	160,93	
Perfil 1,5 cm x 90 cm	15	0,41	5,56	28	11,34	156,66	

\*valores aproximados. \*approximated values.

PAVIMENTO COMBINABLE: SERIE BARI 59,6 cm x 59,6 cm  
FLOOR TILES COMBINATIONS: BARI SERIE 59,6 cm x 59,6 cm







REV. / WALL TILE: CALACATA GOLD 31,6 cm x 90 cm\_PAV. / FLOOR TILE: CALACATA GOLD 59,6 cm x 59,6 cm

# CALACATA

Revestimiento Monoporosa Rectificado / Wall Tiles Rectified



### CALACATA SILVER

31,6 cm x 90 cm x 0,9 cm P3470585 / 100104986 G261

### PERFIL CALACATA SILVER

1,5 cm x 31,6 cm P6209060 / 100106086 G77

1,5 cm x 90 cm P6560248 / 100106087 G97

Butech: Colorstuk Rapid n Blanco B21522247/100236463



### CALACATA GOLD

31,6 cm x 90 cm x 0,9 cm P3470587 / 100104984 G261

### PERFIL CALACATA GOLD

1,5 cm x 31,6 cm P6209061 / 100106084 G77

1,5 cm x 90 cm P6560247 / 100106085 G97

Butech: Colorstuk Rapid n Blanco B21522247/100236463

### EMBALAJE / PACKING

MODELO MODEL	PZ/CJ	M2/CJ	*KG/CJ	CJ/PAL	M2/PAL	*KG/PAL	ADHESIVO ADHESIVE BUTECH
31,6 cm x 90 cm	4	1,14	19,3	57	64,84	1078	Fr-one n / One-flex Premium
Perfil 1,5 cm x 31,6 cm	30	0,28	3,83	42	11,94	161,28	
Perfil 1,5 cm x 90 cm	15	0,41	5,56	28	11,34	156,66	

\*valores aproximados. \*approximated values.



PAVIMENTO COMBINABLE: SERIE CALACATA 59,6 cm x 59,6 cm  
FLOOR TILES COMBINATIONS: CALACATA SERIE 59,6 cm x 59,6 cm





REV. / WALL TILE: MÁRMOL CARRARA BLANCO 31,6 cm x 90 cm\_PAV. / FLOOR TILE: CARRARA BLANCO BRILLO 59,6 cm x 59,6 cm

# MÁRMOL CARRARA BLANCO MOSAICO CARRARA BLANCO

Revestimiento Monoporosa Rectificado / Wall Tiles Rectified



## MÁRMOL CARRARA BLANCO

31,6 cm x 90 cm x 0,9 cm P3470513 / 100096398 G261

## PERFIL MÁRMOL CARRARA BLANCO

1,5 cm x 31,6 cm P6209036 / 100063234 G77

1,5 cm x 90 cm P6560217 / 100063235 G97

Butech: Colorstuk Rapid n Blanco B21522247/100236463



## MOSAICO CARRARA BLANCO

31,6 cm x 90 cm x 0,95 cm P3470555 / 100099103 G271

Butech: Colorstuk Rapid n Blanco B21522247/100236463

### EMBALAJE / PACKING

MODELO MODEL	PZ/CJ	M2/CJ	*KG/CJ	CJ/PAL	M2/PAL	*KG/PAL	ADHESIVO ADHESIVE BUTECH
31,6 cm x 90 cm	4	1,14	18,17	57	64,84	1083	Fr-one n / One-flex Premium
Perfil 1,5 cm x 31,6 cm	30	0,28	3,62	42	11,94	161,3	
Perfil 1,5 cm x 90 cm	15	0,41	5,56	28	11,34	155,74	

\*valores aproximados. \*approximated values.

PAVIMENTO COMBINABLE: SERIE MÁRMOL CARRARA BLANCO 59,6 cm x 59,6 cm  
FLOOR TILES COMBINATIONS: MARMOL CARRARA BLANCO SERIE 59,6 cm x 59,6 cm







REV. / WALL TILE: OLIMPO MARFIL 31,6 cm x 90 cm\_PAV. / FLOOR TILE: OLIMPO MARFIL 59,6 cm x 59,6 cm

# OLIMPO

Revestimiento Monoporosa Rectificado / Wall Tiles Rectified



<b>OLIMPO MARFIL</b>		
31,6 cm x 90 cm x 0,9 cm	P3470786 / 100161049	G261
<b>PERFIL OLIMPO MARFIL</b>		
1,5 cm x 31,6 cm	P6209115 / 100161440	G77
1,5 cm x 90 cm	P6560269 / 100161460	G97
<i>Butech: Colorstuk Rapid n Marfil B21522257/100236794</i>		

RECTIFIED WALL TILES

## EMBALAJE / PACKING

MODELO MODEL	PZ/CJ	M2/CJ	*KG/CJ	CJ/PAL	M2/PAL	*KG/PAL	ADHESIVO ADHESIVE BUTECH
31,6 cm x 90 cm	4	1,14	19,3	57	64,84	1103,97	Fr-one n / One-flex Premium
Perfil 1,5 cm x 31,6 cm	30	0,36	3,83	42	11,94	160,93	
Perfil 1,5 cm x 90 cm	15	0,41	5,56	28	11,34	156,66	

\*valores aproximados. \*approximated values.

PAVIMENTO COMBINABLE: SERIE OLIMPO 59,6 cm x 59,6 cm  
FLOOR TILES COMBINATIONS: OLIMPO SERIE 59,6 cm x 59,6 cm





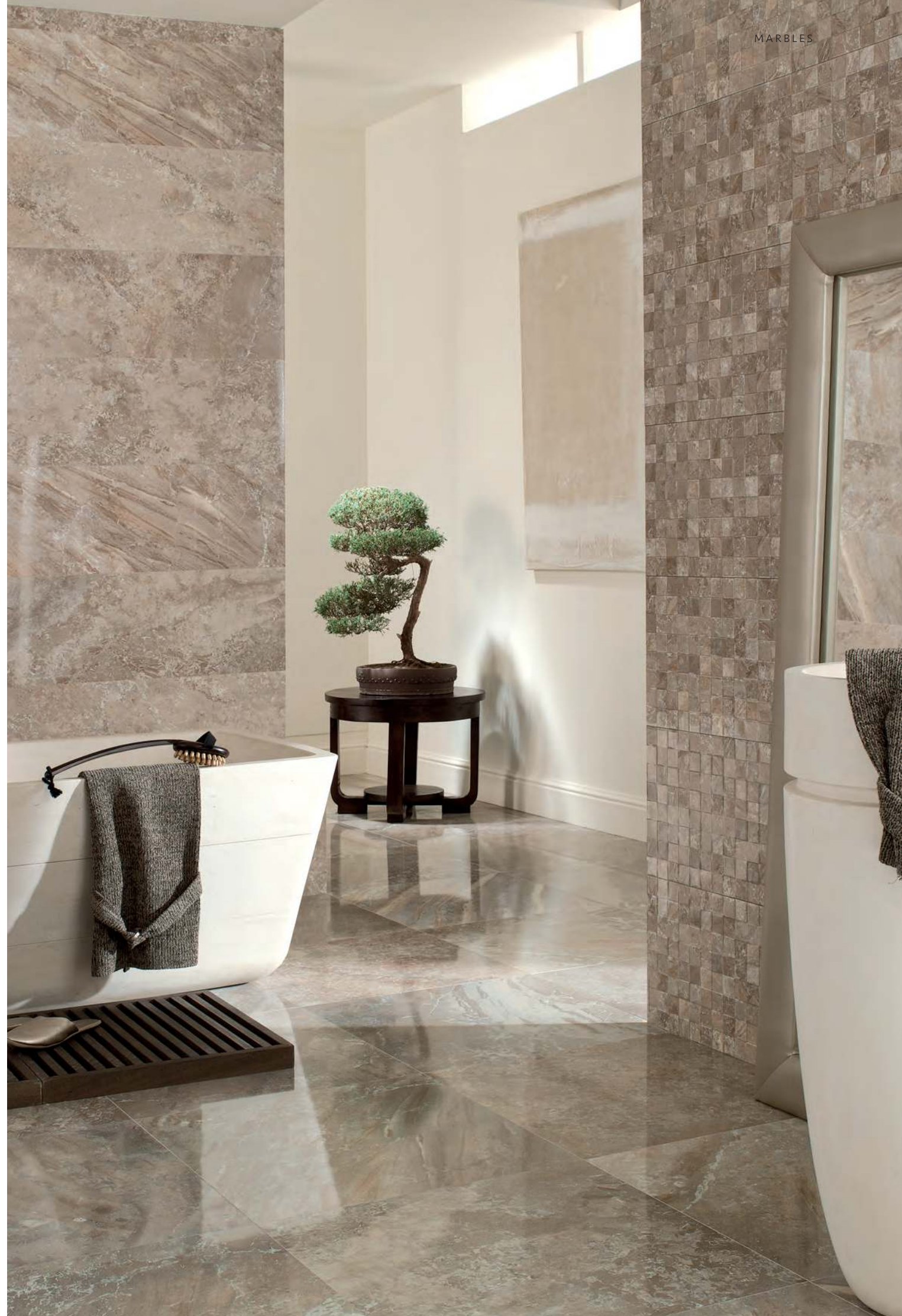

REV. / WALL TILE: RECIFE GRIS 31,6 cm x 90 cm, MOSAICO RECIFE GRIS 31,6 cm x 90 cm\_PAV. / FLOOR TILE: RECIFE GRIS 43,5 cm x 43,5 cm

## RECIFE GRIS MOSAICO RECIFE GRIS

Revestimiento Monoporosa Rectificado / Wall Tiles Rectified



### RECIFE GRIS

31,6 cm x 90 cm x 0,9 cm P3470439 / 100093300 G261

### PERFIL RECIFE GRIS

1,5 cm x 90 cm P6560236 / 100099693 G97

1,5 cm x 31,6 cm P6209054 / 100099692 G77

Butech: Colorstuk Rapid n Manhattan B21522248/100236464



### MOSAICO RECIFE GRIS

31,6 cm x 90 cm x 0,95 cm P3470517 / 100096428 G271

Butech: Colorstuk Rapid n Manhattan B21522248/100236464



### EMBALAJE / PACKING

MODELO MODEL	PZ/CJ	M2/CJ	*KG/CJ	CJ/PAL	M2/PAL	*KG/PAL	ADHESIVO ADHESIVE BUTECH
31,6 cm x 90 cm	4	1,14	18,48	57	64,84	1053	Fr-one n / One-flex Premium
Perfil 1,5 cm x 31,6 cm	30	0,28	3,84	42	11,94	161,28	
Perfil 1,5 cm x 90 cm	15	0,41	5,6	28	11,34	156,66	

\*valores aproximados. \*approximated values.



PAVIMENTO COMBINABLE: SERIE RECIFE 43,5 cm x 43,5 cm  
FLOOR TILES COMBINATIONS: RECIFE SERIE 43,5 cm x 43,5 cm





REV. / WALL TILE: SENA ACERO 31,6 cm x 90 cm

# SENA

Revestimiento Monoporosa Rectificado / Wall Tiles Rectified



## SENA ACERO

31,6 cm x 90 cm x 0,9 cm P3470643 / 100121113 G261

## PERFIL SENA ACERO

1,5 cm x 31,6 cm P6209081 / 100133076 G77

Butech: Colorstuk Rapid n Manhattan B21522248/100236464



## SENA CALIZA

31,6 cm x 90 cm x 0,9 cm P3470644 / 100121115 G261

## PERFIL SENA CALIZA

1,5 cm x 31,6 cm P6209080 / 100133077 G77

Butech: Colorstuk Rapid n Gris B21522258/100236834

### EMBALAJE / PACKING

MODELO MODEL	PZ/CJ	M2/CJ	*KG/CJ	CJ/PAL	M2/PAL	*KG/PAL	ADHESIVO ADHESIVE BUTECH
31,6 cm x 90 cm	4	1,14	19,09	57	64,84	1088,01	Fr-one n / One-flex Premium
Perfil 1,5 cm x 31,6 cm	30	0,28	3,83	42	11,94	160,93	

\*valores aproximados. \*approximated values.



PAVIMENTO COMBINABLE: SERIE SENA 59,6 cm x 59,6 cm  
FLOOR TILES COMBINATIONS: SENA SERIE 59,6 cm x 59,6 cm





REV. / WALL TILE: JERSEY NIEVE 31,6 cm x 90 cm, JERSEY MIX 31,6 cm x 90 cm

# BALI JERSEY

Revestimiento Monoporosa Rectificado / Wall Tiles Rectified



## BALI NIEVE

31,6 cm x 90 cm x 0,9 cm P3470521 / 100096671 G261

### PERFIL BALI NIEVE

1,5 cm x 90 cm P6560110 / 100017092 G97

1,5 cm x 31,6 cm P6200301 / 100016667 G77

Butech: Colorstuk Rapid n Blanco B21522247/100236463



## JERSEY NIEVE

31,6 cm x 90 cm x 0,98 cm P3470569 / 100099345 G271

Butech: Colorstuk Rapid n Blanco B21522247/100236463



PAVIMENTO GRES PORCELÁNICO.  
GRES FLOOR TILE.

## BALI NIEVE

44,3 cm x 44,3 cm x 1 cm P2460041 / 100140438 G311

Butech: Colorstuk Rapid n Blanco B21522247/100236463



## JERSEY MIX

31,6 cm x 90 cm x 0,98 cm P3470572 / 100099792 G271

Butech: Colorstuk Rapid n Gris B21522258/100236834

USO RESTRINGIDO PARA BAÑOS DOMÉSTICOS.

DOMESTIC USE ONLY.

## EMBALAJE / PACKING

MODELO MODEL	PZ/CJ	M2/CJ	*KG/CJ	CJ/PAL	M2/PAL	*KG/PAL	ADHESIVO ADHESIVE BUTECH
Bali 31,6 cm x 90 cm	4	1,14	19	57	64,84	1083	Fr-one n / One-flex Premium
Jersey 31,6 cm x 90 cm	3	0,85	13,68	66	56,31	961,09	
Perfil 1,5 cm x 31,6 cm	30	0,28	3,72	42	11,94	156,24	
Perfil Jersey 1,5 cm x 90 cm	15	0,41	5,4	28	11,34	151,2	
Bali 44,3 cm x 44,3 cm	5	0,98	22,51	66	64,76	1485,36	

\*valores aproximados. \*approximated values.



REV. / WALL TILE: BARBADOS TOPO 31,6 cm x 90 cm

# BARBADOS BARBADOS TOPO

Revestimiento Monoporosa Rectificado / Wall Tiles Rectified



### BARBADOS BASE

31,6 cm x 90 cm x 0,9 cm P3470835 / 100173749 G261

### PERFIL BARBADOS BASE

1,5 cm x 31,6 cm P6209123 / 100174433 G77

*Butech: Colorstuk Rapid n Blanco B21522247/100236463*



### BARBADOS TOPO

31,6 cm x 90 cm x 0,9 cm P3470828 / 100172788 G271

*Butech: Colorstuk Rapid n Blanco B21522247/100236463\_Colorstuk Rapid n Beige B21522252/100236808*



### EMBALAJE / PACKING

MODELO MODEL	PZ/CJ	M2/CJ	*KG/CJ	CJ/PAL	M2/PAL	*KG/PAL	ADHESIVO ADHESIVE BUTECH
31,6 cm x 90 cm	4	1,14	18,31	57	64,84	1049	Fr-one n / One-flex Premium
Topo 31,6 cm x 90 cm	3	0,85	15,58	66	56,31	1057	
Perfil 1,5 cm x 31,6 cm	30	0,28	3,72	42	11,94	161	

\*valores aproximados. \*approximated values.





## GLASS BLANCO LINO BLANCO

Revestimiento Monoporosa Rectificado / Wall Tiles Rectified



### GLASS BLANCO

31,6 cm x 90 cm x 0,9 cm P3470461 / 100095618 G261

### PERFIL GLASS BLANCO

1,5 cm x 31,6 cm P6200337 / 100016785 G77

Butech: Colorstuk Rapid n Blanco B21522247/100236463



### LINO BLANCO

31,6 cm x 90 cm x 0,9 cm P3470481 / 100095760 G261

### PERFIL LINO BLANCO

1,5 cm x 90 cm P6560196 / 100032646 G97

1,5 cm x 31,6 cm P6209004 / 100032661 G77

Butech: Colorstuk Rapid n Blanco B21522247/100236463

### EMBALAJE / PACKING

MODELO MODEL	PZ/CJ	M2/CJ	*KG/CJ	CJ/PAL	M2/PAL	*KG/PAL	ADHESIVO ADHESIVE BUTECH
31,6 cm x 90 cm	4	1,14	19,63	57	64,84	1053	Fr-one n / One-flex Premium
Perfil 1,5 cm x 31,6 cm	30	0,26	3,6	42	11,94	151	
Perfil 1,5 cm x 90 cm	15	0,41	5,4	28	11,34	151,2	

\*valores aproximados. \*approximated values.



REV. / WALL TILE: MARMÍ CHINA 31,6 cm x 90cm, OXO LINE BLANCO 31,6 cm x 90 cm

# MARMÍ CHINA OXO DECO BLANCO OXO LINE BLANCO

Revestimiento Monoporosa Rectificado / Wall Tiles Rectified

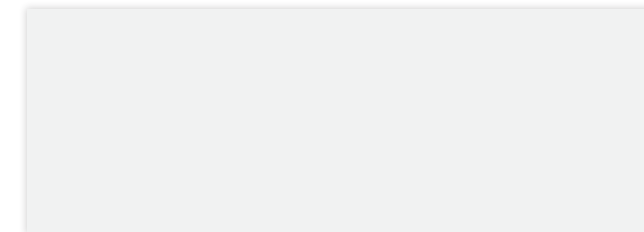

## MARMÍ CHINA

31,6 cm x 90 cm x 0,9 cm P3470501 / 100096152 G261

### PERFIL MARMÍ CHINA

1,5 cm x 90 cm P6560131 / 100017143 G97

1,5 cm x 31,6 cm P6200312 / 100016703 G77

Butech: Colorstuk Especial n White B24302055 / 100238236

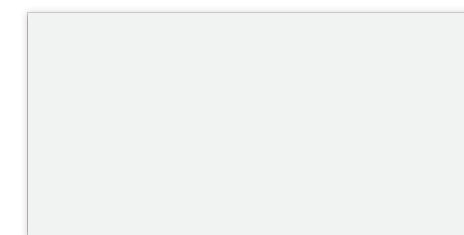

## MARMÍ CHINA

31,6 cm x 59,2 cm x 0,9 cm P3219250 / 100108706 G240

### PERFIL MARMÍ CHINA

1,5 cm x 59,2 cm P5730112 / 100016285 G92

1,5 cm x 31,6 cm P6200312 / 100016703 G77

Butech: Colorstuk Rapid n Blanco B21522247/100236463



## OXO LINE BLANCO

31,6 cm x 90 cm x 1,06 cm P3470589 / 100105125 G271

Butech: Colorstuk Especial n White B24302055 / 100238236



## OXO DECO BLANCO

31,6 cm x 90 cm x 1,05 cm P3470590 / 100105124 G271

Butech: Colorstuk Especial n White B24302055 / 100238236

### EMBALAJE / PACKING

MODELO MODEL	PZ/CJ	M2/CJ	*KG/CJ	CJ/PAL	M2/PAL	*KG/PAL	ADHESIVO ADHESIVE BUTECH
31,6 cm x 90 cm	4	1,14	19,36	57	64,84	1103,75	Fr-one n / One-flex Premium
Oxo 31,6 cm x 90 cm	3	0,85	13,8	66	56,31	913,9	
Perfil Marmí C. 15cm x 31,6cm	30	0,28	3,72	42	11,94	156,24	
Perfil Marmí C. 15cm x 90cm	15	0,41	5,4	28	11,34	151,2	
Marmí C. 31,6 cm x 59,2 cm	6	1,13	17,8	72	81,22	1281,48	

\*valores aproximados. \*approximated values.



# MARMI BLANCO MARMI DECO BLANCO

Revestimiento Monoporosa Rectificado / Wall Tiles Rectified



REV. / WALL TILE: MARMI DECO BLANCO 31,6 cm x 90 cm \_PAV. / FLOOR TILE: OXFORD ACERO 14,3 cm x 90 cm / 22 cm x 90 cm

RECTIFIED WALL TILES

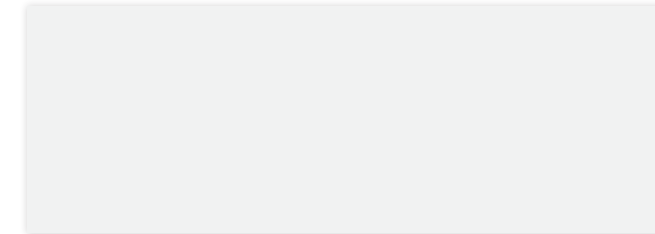

**MARMI BLANCO**  
 31,6 cm x 90 cm x 0,9 cm P3470505 / 100096151 G261  
**PERFIL MARMI BLANCO**  
 1,5 cm x 90 cm P6560130 / 100017139 G97  
 1,5 cm x 31,6 cm P6200311 / 100016699 G77  
*Butech: Colorstuk Especial n White B24302055 / 100238236*



**MARMI DECO BLANCO**  
 31,6 cm x 90 cm x 1,1 cm P3470595 / 100105230 G271  
*Butech: Colorstuk Especial n White B24302055 / 100238236*

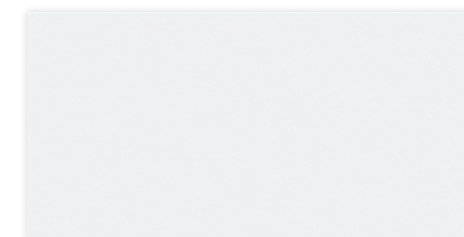

**MARMI BLANCO**  
 31,6 cm x 59,2 cm x 0,9 cm P3219253 / 100108705 G240  
**PERFIL MARMI BLANCO**  
 1,5 cm x 59,2 cm P5730110 / 100016277 G92  
 1,5 cm x 31,6 cm P6200311 / 100016699 G77  
*Butech: Colorstuk Rapid n Blanco B21522247/100236463*

**EMBALAJE / PACKING**

MODELO MODEL	PZ/CJ	M2/CJ	*KG/CJ	CJ/PAL	M2/PAL	*KG/PAL	ADHESIVO ADHESIVE BUTECH
31,6 cm x 90 cm	4	1,14	18,5	57	64,84	1057,9	Fr-one n / One-flex Premium
Perfil Marmi B. 1,5cmx31,6cm	30	0,28	3,8	42	11,94	161,2	
Perfil Marmi B. 1,5cmx90cm	15	0,41	5,59	28	11,34	156,6	
Marmi Deco 31,6 cm x 90 cm	3	0,85	15,07	66	56,31	994,9	
Marmi B. 31,6 cm x 59,2 cm	6	1,13	17,8	72	81,22	1281,48	
Perfil Marmi B. 1,5cmx59,6cm	15	0,13	3,44	56	7,46	222	

\*valores aproximados. \*approximated values.



# MENORCA BLANCO MENORCA LINE MENORCA HOJAS

Revestimiento Monoporosa Rectificado / Wall Tiles Rectified



## MENORCA BLANCO

31,6 cm x 90 cm x 0,9 cm P3470821 / 100172742 G261

## PERFIL MENORCA BLANCO

1,5 cm x 31,6 cm P6209122 / 100173562 G77

Butech: Colorstuk Rapid n Blanco B21522247/100236463



## MENORCA LINE GRIS

31,6 cm x 90 cm x 0,9 cm P3470818 / 100172806 G271

Butech: Colorstuk Rapid n Blanco B21522247/100236463\_Colorstuk Rapid n Gris B21522258/100236834



## MENORCA HOJAS TOPO

31,6 cm x 90 cm x 0,9 cm P3470819 / 100172798 G271

Butech: Colorstuk Rapid n Beige B21522252/100236808



## MENORCA HOJAS GRIS

31,6 cm x 90 cm x 0,9 cm P3470823 / 100172805 G271

Butech: Colorstuk Rapid n Gris B21522258/100236834

## EMBALAJE / PACKING

MODELO MODEL	PZ/CJ	M2/CJ	*KG/CJ	CJ/PAL	M2/PAL	*KG/PAL	ADHESIVO ADHESIVE BUTECH
Menorca B. 31,6 cm x 90 cm	4	1,14	16,2	57	64,84	1028	Fr-one n / One-flex Premium
Menorca L. 31,6 cm x 90 cm	3	0,85	12,12	57	48,63	884,92	
Menorca H. 31,6 cm x 90 cm	3	0,85	14,99	66	56,31	980,10	
Perfil 1,5 cm x 31,6 cm	30	0,28	3,72	42	11,94	161,28	

\*valores aproximados. \*approximated values.





REV. / WALL TILE: SEÚL NÁCAR 31,6 cm x 90 cm

## SEÚL NÁCAR QATAR NÁCAR

Revestimiento Monoporosa Rectificado / Wall Tiles Rectified



### SEÚL NÁCAR

31,6 cm x 90 cm x 0,9 cm P3470475 / 100095770 G261

### PERFIL SEÚL NÁCAR

1,5 cm x 90 cm P6560218 / 100072354 G97

1,5 cm x 31,6 cm P6209041 / 100072353 G77

Butech: Colorstuk Rapid n Blanco B21522247/100236463



### QATAR NÁCAR

31,6 cm x 90 cm x 1,03 cm P3470486 / 100095767 G271

Butech: Colorstuk Rapid n Blanco B21522247/100236463



### EMBALAJE / PACKING

MODELO MODEL	PZ/CJ	M2/CJ	*KG/CJ	CJ/PAL	M2/PAL	*KG/PAL	ADHESIVO ADHESIVE BUTECH
Seúl 31,6 cm x 90 cm	4	1,13	18,54	57	64,84	1057	Fr-one n / One-flex Premium
Qatar 31,6 cm x 90 cm	3	0,85	14,16	66	56,31	934,56	
Perfil 1,5 cm x 31,6 cm	30	0,28	3,6	42	11,94	151	
Perfil 1,5 cm x 90 cm	15	0,41	5,4	28	11,34	151,2	

\*valores aproximados. \*approximated values.



REV. / WALL TILE: STUDIO WHITE 31,6 cm x 90 cm, RETRO STUDIO METAL 31,6 cm x 90 cm

# STUDIO DECO STUDIO MOSAICO STUDIO RETRO STUDIO

Revestimiento Monoporosa Rectificado / Wall Tiles Rectified

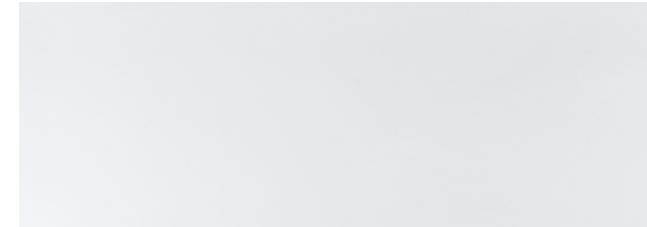

## STUDIO WHITE

31,6 cm x 90 cm x 0,90 cm P3470903 / 100240026 G261

## PERFIL STUDIO WHITE

1,5 cm x 31,6 cm P6209142 / 100240911 G77

1,5 cm x 90cm P6560292 / 100240893 G97

Butech: Colorstuk 0-4 Blanco B21522237/100236442



## DECO STUDIO WHITE

31,6 cm x 90 cm x 0,90 cm P3470896 / 100239816 G271

Butech: Colorstuk 0-4 Blanco B21522237/100236442

DECO STUDIO ESTÁ FORMADA POR 3 DECORADOS DISTINTOS ALEATORIOS.  
DECO STUDIO IS MADE IN 3 DIFFERENT RANDOM PATTERNS.



## MOSAICO STUDIO WHITE

31,6 cm x 90 cm x 0,90 cm P3470899 / 100239875 G271

Butech: Colorstuk 0-4 Blanco B21522237/100236442



## RETRO STUDIO WHITE

31,6 cm x 90 cm x 0,90 cm P3470901 / 100239998 G271

Butech: Colorstuk 0-4 Blanco B21522237/100236442

### EMBALAJE / PACKING

MODELO MODEL	PZ/CJ	M2/CJ	*KG/CJ	CJ/PAL	M2/PAL	*KG/PAL	ADHESIVO ADHESIVE BUTECH
Studio 31,6 cm x 90 cm	4	1,14	18,82	57	64,84	1072,97	Fr-one n / One-flex Premium
31,6 cm x 90 cm **	3	0,85	14,09	66	56,31	929,97	
Perfil 1,5 cm x 31,6 cm	30	0,28	3,72	42	11,94	156,24	
Perfil 1,5 cm x 90 cm	15	0,41	5,4	28	11,34	151,2	

\*\* Deco, Mosaico, Retro  
\*valores aproximados. \*approximated values.



# STUDIO DECO STUDIO MOSAICO STUDIO RETRO STUDIO

Revestimiento Monoporosa Rectificado / Wall Tiles Rectified

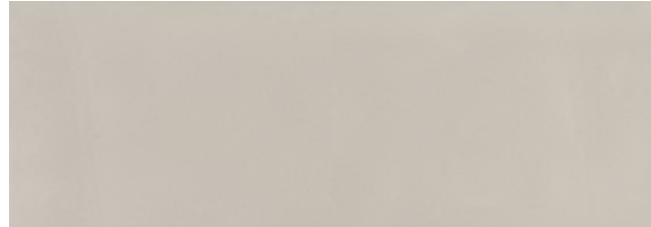

**STUDIO TAUPE**  
31,6 cm x 90 cm x 1 cm P3470902 / 100240022 G261

**PERFIL STUDIO TAUPE**  
1,5 cm x 31,6 cm P6209143 / 100240892 G77  
1,5 cm x 90 cm P6560291 / 100240920 G97

Butech: Colorstuk Especial Maple B51201055/100243271



**DECO STUDIO TAUPE**  
31,6 cm x 90 cm x 1,14 cm P3470898 / 100239840 G271

Butech: Colorstuk Especial Maple B51201055/100243271

DECO STUDIO ESTÁ FORMADA POR 3 DECORADOS DISTINTOS ALEATORIOS.  
DECO STUDIO IS MADE IN 3 DIFFERENT RANDOM PATTERNS.



**MOSAICO STUDIO TAUPE**  
31,6 cm x 90 cm x 1,03 cm P3470897 / 100239850 G271

Butech: Colorstuk Especial Maple B51201055/100243271



**RETRO STUDIO TAUPE**  
31,6 cm x 90 cm x 1,07 cm P3470900 / 100239876 G271

Butech: Colorstuk Especial Maple B51201055/100243271

## EMBALAJE / PACKING

MODELO MODEL	PZ/CJ	M2/CJ	*KG/CJ	CJ/PAL	M2/PAL	*KG/PAL	ADHESIVO ADHESIVE BUTECH
Studio 31,6 cm x 90 cm	4	1,14	18,82	57	64,84	1072,97	Fr-one n / One-flex Premium
31,6 cm x 90 cm **	3	0,85	14,09	66	56,31	929,97	
Perfil 1,5 cm x 31,6 cm	30	0,28	3,72	42	11,94	156,24	
Perfil 1,5 cm x 90 cm	15	0,41	5,4	28	11,34	151,2	

\*\* Deco, Mosaico, Retro  
\*valores aproximados. \*\*approximated values.

# STUDIO DECO STUDIO MOSAICO STUDIO RETRO STUDIO

Revestimiento Monoporosa Rectificado / Wall Tiles Rectified



**STUDIO METAL**  
31,6 cm x 90 cm x 1 cm P3470905 / 100240131 G287

Butech: Colorstuk Especial Antracita B21522236/100204554

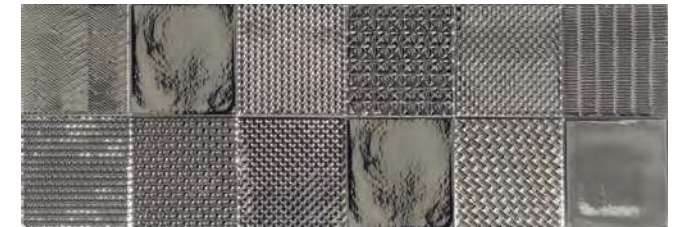

**DECO STUDIO METAL**  
31,6 cm x 90 cm x 1,14 cm P3470906 / 100240237 G287

Butech: Colorstuk Especial Antracita B21522236/100204554

DECO STUDIO ESTÁ FORMADA POR 3 DECORADOS DISTINTOS ALEATORIOS.  
DECO STUDIO IS MADE IN 3 DIFFERENT RANDOM PATTERNS.



**MOSAICO STUDIO METAL**  
31,6 cm x 90 cm x 1,03 cm P3470904 / 100240125 G287

Butech: Colorstuk Especial Antracita B21522236/100204554

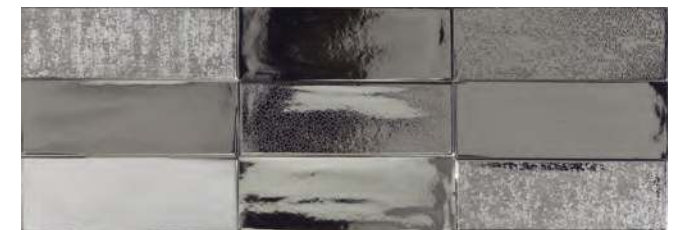

**RETRO STUDIO METAL**  
31,6 cm x 90 cm x 1,07 cm P3470907 / 100240141 G287

Butech: Colorstuk Especial Antracita B21522236/100204554

- **ADHESIVO RECOMENDADO - RECOMMENDED ADHESIVE** - Fr-one n
- **ÁMBITO DE USO - FIELD OF USE** - Revestimiento de paredes interiores - Interior wall covering.

• **ATENCIÓN. PRODUCTO ESPECIAL**  
La manipulación indebida durante la colocación y rejuntado, puede causar rayados y rozaduras de los que PORCELANOSA S.A. no se hace responsable - No utilizar para la retirada de material de rejuntado y la limpieza del producto agentes abrasivos - Evitar contactos prolongados de la superficie decorada con ácidos y álcalis - Se recomienda usar como agentes de limpieza únicamente agua y jabón neutro - Al tratarse de un material delicado, su manipulación ha de ser cuidadosa. Adoptar métodos de colocación específicos del tipo de material (utilizar adhesivos y material de rejuntado apropiados) - Evitar, durante la instalación, el uso de utensilios que puedan dañar el material cerámico - Utilizar técnica de doble encolado (aplicando material de agarre en la pieza y el soporte a embaldosar) para evitar las indeseables zonas vacías - No prolongar en exceso el secado del material de rejuntado en la superficie - Para el corte de las piezas, utilizar cortadoras e ingleteadoras eléctricas con disco refrigerado con agua.

• **WARNING: SPECIALS PRODUCTS**  
Improper manipulation during fixing and grouting can cause scratches for which PORCELANOSA S.A. will not take responsibility - Do not use abrasive agents to clean this product - Avoid long contact of the decorated surface with acids and alkalis - Use only hot water and mild soap as cleaning agents - This is a delicate material that must be handled with care. Use specific installation methods (use the proper bonding material) - Do not use tools that could damage material during installation - Use the floating and buttering method, applying the bonding material to both the back of the piece and the substrate, so as to ensure that there are no unwanted voids - Grouting material should not be left to dry for a too long time in the surface - To cut pieces, use electric water-cooled cutters and mitring saw.

## EMBALAJE / PACKING

MODELO MODEL	PZ/CJ	M2/CJ	*KG/CJ	CJ/PAL	M2/PAL	*KG/PAL	ADHESIVO ADHESIVE BUTECH
31,6 cm x 90 cm	3	0,85	13,98	36	30,71	503,25	Fr-one n / One-flex Premium

\*valores aproximados. \*\*approximated values.

# BRUNEI

Revestimiento Monoporosa Rectificado / Wall Tiles Rectified

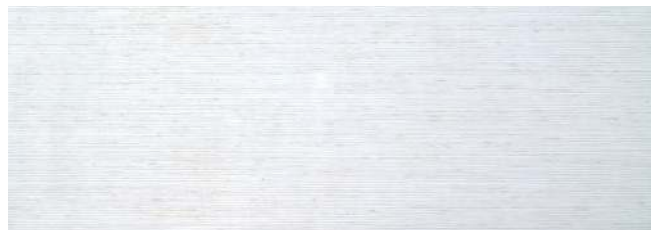

## BRUNEI BLANCO

31,6 cm x 90 cm x 0,9 cm P3470492 / 100095750 G261

## PERFIL BRUNEI

1,5 cm x 31,6 cm P6209026 / 100058517 G77

*Butech: Colorstuk Rapid n Blanco B21522247/100236463*

### EMBALAJE / PACKING

MODELO MODEL	PZ/CJ	M2/CJ	*KG/CJ	CJ/PAL	M2/PAL	*KG/PAL	ADHESIVO ADHESIVE BUTECH
31,6 cm x 90 cm	4	1,14	18,56	57	64,84	1055	Fr-one n / One-flex Premium
Perfil 1,5 cm x 31,6 cm	30	0,26	3,83	42	11,94	160,93	

\*valores aproximados. \*approximated values.

# JAPAN

Revestimiento Monoporosa Rectificado / Wall Tiles Rectified



## JAPAN BLANCO

31,6 cm x 90 cm x 0,9 cm P3470669 / 100135524 G261

## PERFIL JAPAN BLANCO

1,5 cm x 31,6 cm P6209103 / 100138755 G77

*Butech: Colorstuk Rapid n Gris B21522258/100236834*



## JAPAN MARINE

31,6 cm x 90 cm x 0,9 cm P3470658 / 100135530 G261

## PERFIL JAPAN MARINE

1,5 cm x 31,6 cm P6209088 / 100138757 G77

*Butech: Colorstuk Rapid n Cemento B21522249/100236449*

### EMBALAJE / PACKING

MODELO MODEL	PZ/CJ	M2/CJ	*KG/CJ	CJ/PAL	M2/PAL	*KG/PAL	ADHESIVO ADHESIVE BUTECH
31,6 cm x 90 cm	4	1,14	18,56	57	64,84	1055	Fr-one n / One-flex Premium
Perfil 1,5 cm x 31,6 cm	30	0,26	3,83	42	11,94	160,93	

\*valores aproximados. \*approximated values.





# LISTÓN OXFORD TACO OXFORD

Revestimiento Monoporosa Rectificado / Wall Tiles Rectified



**LISTÓN OXFORD COGNAC**  
 31,6 cm x 90 cm x 1,1 cm P3470662 / 100135534 G271  
 Butech: Colorstuk Rapid n Moka: B21522260/100236824



**TACO OXFORD COGNAC**  
 31,6 cm x 90 cm x 1,25 cm P3470677 / 100135554 G271  
 Butech: Colorstuk Rapid n Moka: B21522260/100236824



**LISTÓN OXFORD NATURAL**  
 31,6 cm x 90 cm x 1,1 cm P3470657 / 100135535 G271  
 Butech: Colorstuk Rapid n Tabaco B21522255/100236823



**TACO OXFORD NATURAL**  
 31,6 cm x 90 cm x 1,25 cm P3470678 / 100135555 G271  
 Butech: Colorstuk Rapid n Tabaco B21522255/100236823

RECTIFIED WALL TILES

REV. / WALL TILE: TACO OXFORD NATURAL 31,6 cm x 90cm \_PAV. / FLOOR TILE: OXFORD NATURAL 14,3 cm x 90 cm / 22 cm x 90 cm

## EMBALAJE / PACKING

MODELO MODEL	PZ/CJ	M2/CJ	*KG/CJ	CJ/PAL	M2/PAL	*KG/PAL	ADHESIVO ADHESIVE BUTECH
Listón 31,6 cm x 90 cm	3	0,85	16,22	66	56,31	1064,57	Fr-one n / One-flex Premium
Taco 31,6 cm x 90 cm	3	0,85	15,9	57	48,63	906,9	

\*valores aproximados. \*approximated values.





# MADISON

Revestimiento Monoporosa Rectificado / Wall Tiles Rectified



## MADISON NÁCAR

31,6 cm x 90 cm x 0,9 cm P3470563 / 100099090 G271

Butech: Colorstuk Rapid n Blanco B21522247/100236463



## MADISON ANTRACITA

31,6 cm x 90 cm x 0,9 cm P3470574 / 100099872 G271

Butech: Colorstuk Rapid n Negro B21522251/100236475



## MADISON PLATA

31,6 cm x 90 cm x 0,9 cm P3470601 / 100111752 G287

Butech: Colorstuk Rapid n Antracita B21522250/100236481

## MADISON PLATA

- **ADHESIVO RECOMENDADO** - RECOMMENDED ADHESIVE - Fr-one n
- **ÁMBITO DE USO** - FIELD OF USE - Revestimiento de paredes interiores - Interior wall covering.

• **ATENCIÓN: PRODUCTO ESPECIAL**  
 La manipulación indebida durante la colocación y rejuntado, puede causar rayados y rozaduras de los que PORCELANOSA S.A. no se hace responsable - No utilizar para la retirada de material de rejuntado y la limpieza del producto agentes abrasivos - Evitar contactos prolongados de la superficie decorada con ácidos y álcalis - Se recomienda usar como agentes de limpieza únicamente agua y jabón neutro - Al tratarse de un material delicado, su manipulación ha de ser cuidadosa. Adoptar métodos de colocación específicos del tipo de material (utilizar adhesivos y material de rejuntado apropiados) - Evitar, durante la instalación, el uso de utensilios que puedan dañar el material cerámico - Utilizar técnica de doble encolado (aplicando material de agarre en la pieza y el soporte a embaldosar) para evitar las indeseables zonas vacías - No prolongar en exceso el secado del material de rejuntado en la superficie - Para el corte de las piezas, utilizar cortadoras e ingleteadoras eléctricas con disco refrigerado con agua.

• **WARNING: SPECIALS PRODUCTS**  
 Improper manipulation during fixing and grouting can cause scratches for which PORCELANOSA S.A. will not take responsibility - Do not use abrasive agents to clean this product - Avoid long contact of the decorated surface with acids and alkalis - Use only hot water and mild soap as cleaning agents - This is a delicate material that must be handled with care. Use specific installation methods (use the proper bonding material) - Do not use tools that could damage material during installation - Use the floating and buttering method, applying the bonding material to both the back of the piece and the substrate, so as to ensure that there are no unwanted voids - Grouting material should not be left to dry for a too long time in the surface - To cut pieces, use electric water-cooled cutters and mitring saw

## EMBALAJE / PACKING

MODELO MODEL	PZ/CJ	M2/CJ	*KG/CJ	CJ/PAL	M2/PAL	*KG/PAL	ADHESIVO ADHESIVE BUTECH
31,6 cm x 90 cm	4	1,14	18,17	57	64,84	1077	Fr-one n / One-flex Premium
M. Plata 31,6 cm x 90 cm	3	0,85	13,18	36	13,87	517,37	

\*valores aproximados. \*approximated values.



# SAFARI

Revestimiento Monoporosa Rectificado / Wall Tiles Rectified



## SAFARI ARENA

31,6 cm x 90 cm x 0,9 cm P3470822 / 100172733 G261

## PERFIL SAFARI ARENA

1,5 cm x 31,6 cm P6209121 / 100173563 G77

*Butech: Colorstuk Rapid n Beige B21522252/100236808*



## SAFARI CALIZA

31,6 cm x 90 cm x 0,9 cm P3470824 / 100172734 G261

## PERFIL SAFARI CALIZA

1,5 cm x 31,6 cm P6209120 / 100173570 G77

*Butech: Colorstuk Rapid n Marfil B21522257/100236794*

### EMBALAJE / PACKING

MODELO MODEL	PZ/CJ	M2/CJ	*KG/CJ	CJ/PAL	M2/PAL	*KG/PAL	ADHESIVO ADHESIVE BUTECH
31,6 cm x 90 cm	4	1,14	16,2	57	64,84	923,4	Fr-one n / One-flex Premium
Perfil 1,5 cm x 31,6 cm	30	0,26	3,72	42	11,94	156,24	

\*valores aproximados. \*approximated values.



PAVIMENTO COMBINABLE: SERIE SAFARI 59,6 cm x 59,6 cm  
FLOOR TILES COMBINATIONS: SAFARI SERIE 59,6 cm x 59,6 cm

# YAKARTA

Revestimiento Monoporosa Rectificado / Wall Tiles Rectified



## YAKARTA BLANCO

31,6 cm x 90 cm x 0,93 cm P3470502 / 100096156 G261

## PERFIL YAKARTA BLANCO

1,5 cm x 31,6 cm P6200371 / 100029155 G77

*Butech: Colorstuk Rapid n Beige B21522252/100236808*

### EMBALAJE / PACKING

MODELO MODEL	PZ/CJ	M2/CJ	*KG/CJ	CJ/PAL	M2/PAL	*KG/PAL	ADHESIVO ADHESIVE BUTECH
31,6 cm x 90 cm	4	1,14	18,56	57	64,84	1055	Fr-one n / One-flex Premium
Perfil 1,5 cm x 31,6 cm	30	0,26	3,83	42	11,94	160,93	

\*valores aproximados. \*approximated values.

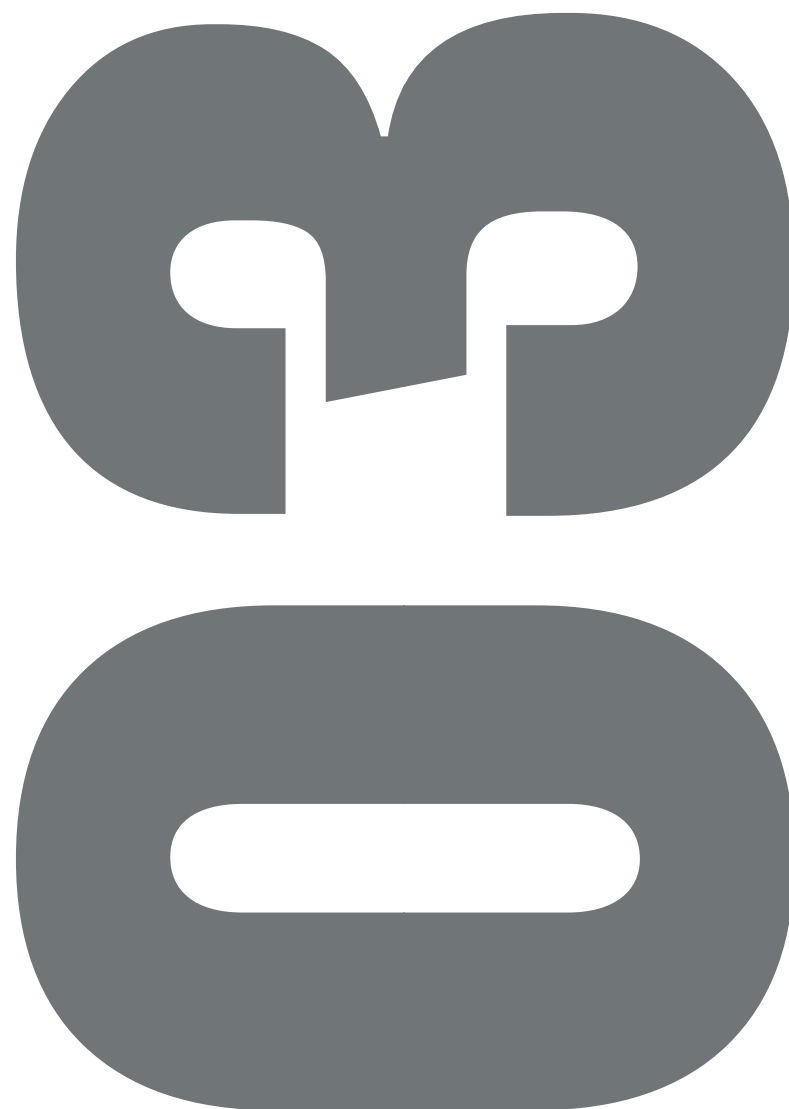

Singulares diseños en relieve y materiales naturales inspiran las colecciones de revestimientos, ofreciendo múltiples posibilidades decorativas en cualquier espacio.

## REVESTI- MIENTO

*Unique embossed designs and natural materials inspire our collections of coverings, providing multiple decorative opportunities for any space.*

## WALL TILES



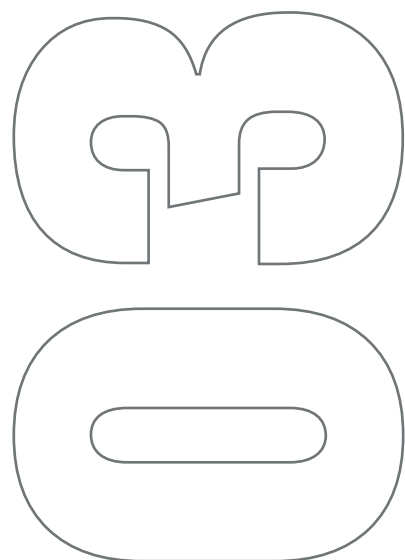

STONES & CONCRETES		31,6 cm x 59,2 cm	25 cm x 44,3 cm	
MARBELLA _ SPIGA BOTTEGA _ BOTTEGA	132			
DOVER ANTIQUE _ DOVER MODERN LINE _ DOVER	135			
MOSAICO NANTES _ NANTES	136			NEW
NAST	137			
RODANO LINEAL _ MOSAICO RODANO _ DECO RODANO _ RODANO	138			NEW
	150		BOTTEGA _ MARBELLA	NEW
	151		NIMBUS	
	152		PARK _ PARK LINEAL	
MARBLES				
MÁRMOL CARRARA BLANCO	142			
SENA	143			
	153		FONTANA	NEW
WHITES				
OXO DECO BLANCO _ CHINA BLANCO	144			
GLASS BLANCO	145			
	154		MÁLAGA	
	155		RONDA	
	156		CHINA BLANCO	
	157		TECNOS	
TEXTURES				
JAPAN	147			
JAMAICA _ KINGSTON	149			
	158		BALI _ JERSEY	
	159		JAPAN	

# BOTTEGA SPIGA BOTTEGA

Revestimiento Monoporosa / Wall Tiles



## BOTTEGA ACERO

31,6 cm x 59,2 cm x 0,87 cm P3219316 / 100225102 G226

Butech: Colorstuk Rapid n Manhattan B21522248/100236464



## BOTTEGA CALIZA

31,6 cm x 59,2 cm x 0,87 cm P3219319 / 100225103 G226

Butech: Colorstuk Rapid n Gris B21522258/100236834



## SPIGA BOTTEGA ACERO

31,6 cm x 59,2 cm x 0,87 cm P3219317 / 100225056 G233

Butech: Colorstuk Rapid n Manhattan B21522248/100236464



## SPIGA BOTTEGA CALIZA

31,6 cm x 59,2 cm x 0,87 cm P3219318 / 100225104 G233

Butech: Colorstuk Rapid n Gris B21522258/100236834



### EMBALAJE / PACKING

MODELO MODEL	PZ/CJ	M2/CJ	*KG/CJ	CJ/PAL	M2/PAL	*KG/PAL	ADHESIVO ADHESIVE BUTECH
31,6 cm x 59,2 cm	6	1,13	16,32	72	81,22	1210,29	Tixocem + / One-flex Premium

\*valores aproximados. \*approximated values.

# BOTTEGA SPIGA BOTTEGA MARBELLA

Revestimiento Monoporosa / Wall Tiles



## BOTTEGA WHITE

31,6 cm x 59,2 cm x 0,87 cm P3219330 / 100242771 G226

Butech: Colorstuk Rapid n Gris B21522258/100236834



## MARBELLA STONE

31,6 cm x 59,2 cm x 0,87 cm P3219321 / 100241404 G233

Butech: Colorstuk Rapid n Manhattan B21522248/100236464

MARBELLA STONE ESTÁ FORMADA POR 6 DECORADOS DISTINTOS ALEATORIOS.  
MARBELLA STONE IS MADE IN 6 DIFFERENT RANDOM PATTERNS.



## SPIGA BOTTEGA WHITE

31,6 cm x 59,2 cm x 0,87 cm P3219329 / 100242747 G233

Butech: Colorstuk Rapid n Gris B21522258/100236834



### EMBALAJE / PACKING

MODELO MODEL	PZ/CJ	M2/CJ	*KG/CJ	CJ/PAL	M2/PAL	*KG/PAL	ADHESIVO ADHESIVE BUTECH
31,6 cm x 59,2 cm	6	1,13	16,32	72	81,22	1210,29	Tixocem + / One-flex Premium

\*valores aproximados. \*approximated values.



PAVIMENTO COMBINABLE: SERIE BOTTEGA 44,3 cm x 44,3 cm  
FLOOR TILES COMBINATIONS: BOTTEGA SERIE 44,3 cm x 44,3 cm





# DOVER DOVER MODERN LINE DOVER ANTIQUE

Revestimiento Monoporosa / Wall Tiles



**DOVER ACERO**  
31,6 cm x 59,2 cm x 0,9 cm P3219280 / 100157353 G226  
Butech: Colorstuk Rapid n Gris B21522258/100236834



**DOVER CALIZA**  
31,6 cm x 59,2 cm x 0,9 cm P3219283 / 100157356 G226  
Butech: Colorstuk Rapid n Gris B21522258/100236834



**DOVER MODERN LINE ACERO**  
31,6 cm x 59,2 cm x 1,14 cm P3219281 / 100157373 G233  
Butech: Colorstuk Rapid n Gris B21522258/100236834



**DOVER MODERN LINE CALIZA**  
31,6 cm x 59,2 cm x 1,14 cm P3219282 / 100157374 G233  
Butech: Colorstuk Rapid n Gris B21522258/100236834



**DOVER ANTIQUE**  
31,6 cm x 59,2 cm x 0,9 cm P3219277 / 100157355 G233  
Butech: Colorstuk Rapid n Cemento B21522249/100236449



PAVIMENTO COMBINABLE: SERIE DOVER 44,3 cm x 44,3 cm  
FLOOR TILES COMBINATIONS: DOVER SERIE 44,3 cm x 44,3 cm

DOVER ANTIQUE ESTÁ FORMADO POR 9 DECORADOS DISTINTOS ALEATORIOS.  
DOVER ANTIQUE RANGE IS MADE IN 9 DIFFERENT RANDOM PATTERNS.

## EMBALAJE / PACKING

MODELO MODEL	PZ/CJ	M2/CJ	*KG/CJ	CJ/PAL	M2/PAL	*KG/PAL	ADHESIVO ADHESIVE BUTECH
31,6 cm x 59,2 cm	6	1,13	15,72	72	81,22	1131,84	Tixocem + / One-flex Premium
Modern 31,6 cm x 59,2 cm	5	0,94	14,35	72	67,68	1033,2	

\*valores aproximados. \*approximated values.

# NANTES MOSAICO NANTES

Revestimiento Monoporosa / Wall Tiles



**NEW**



**NANTES ACERO**

31,6 cm x 59,2 cm x 0,87 cm P3219332 / 100273263 G226

Butech: Colorstuk Rapid n Gris B21522258/100236834



**NANTES CALIZA**

31,6 cm x 59,2 cm x 0,87 cm P3219331 / 100273302 G226

Butech: Colorstuk Rapid n Gris B21522258/100236834



**MOSAICO NANTES ACERO**

31,6 cm x 59,2 cm x 1,13 cm P3219333 / 100273564 G233

Butech: Colorstuk Rapid n Gris B21522258/100236834



**MOSAICO NANTES CALIZA**

31,6 cm x 59,2 cm x 1,13 cm P3219334 / 100273518 G233

Butech: Colorstuk Rapid n Gris B21522258/100236834



PAVIMENTO COMBINABLE: SERIE NANTES 44,3 cm x 44,3 cm  
FLOOR TILES COMBINATIONS: NANTES SERIE 44,3 cm x 44,3 cm

**EMBALAJE / PACKING**

MODELO MODEL	PZ/CJ	M2/CJ	*KG/CJ	CJ/PAL	M2/PAL	*KG/PAL	ADHESIVO ADHESIVE BUTECH
31,6 cm x 59,2 cm	6	1,13	15,72	72	81,12	1304,62	Tixocem + / One-flex Premium
Mosaico 31,6 cm x 59,2 cm	5	0,94	14,35	72	67,68	1033,2	

\*valores aproximados. \*approximated values.

# NAST

Revestimiento Monoporosa / Wall Tiles

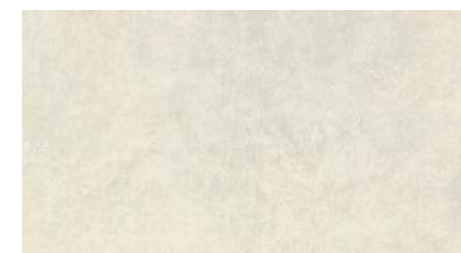

**NAST BLANCO**

31,6 cm x 59,2 cm x 0,87 cm P3219339 / 100276152 G226

Butech: Colorstuk Rapid n Marfil B21522257/100236794



**NAST BROWN**

31,6 cm x 59,2 cm x 0,87 cm P3219337 / 100276333 G226

Butech: Colorstuk Rapid n Manhattan B21522248/100236464



**NAST CALIZA**

31,6 cm x 59,2 cm x 0,87 cm P3219335 / 100276344 G226

Butech: Colorstuk Rapid n Marfil B21522257/100236794



**NAST DARK**

31,6 cm x 59,2 cm x 0,87 cm P3219336 / 100276345 G226

Butech: Colorstuk Rapid n Cemento B21522249/100236449

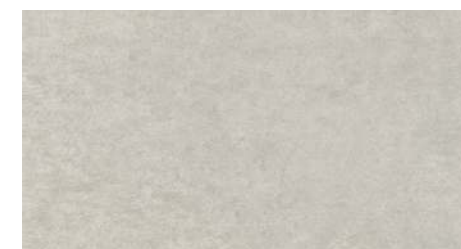

**NAST GREY**

31,6 cm x 59,2 cm x 0,87 cm P3219338 / 100276176 G226

Butech: Colorstuk Rapid n Gris B21522258/100236834

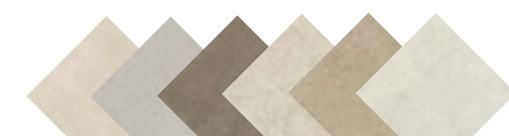

PAVIMENTO COMBINABLE: SERIE NAST 44,3 cm x 44,3 cm  
FLOOR TILES COMBINATIONS: NAST SERIE 44,3 cm x 44,3 cm

**EMBALAJE / PACKING**

MODELO MODEL	PZ/CJ	M2/CJ	*KG/CJ	CJ/PAL	M2/PAL	*KG/PAL	ADHESIVO ADHESIVE BUTECH
31,6 cm x 59,2 cm	6	1,13	15,72	72	81,22	1131,84	Tixocem + / One-flex Premium

\*valores aproximados. \*approximated values.



# RODANO DECO RODANO MOSAICO RODANO RODANO LINEAL

Revestimiento Monoporosa / Wall Tiles

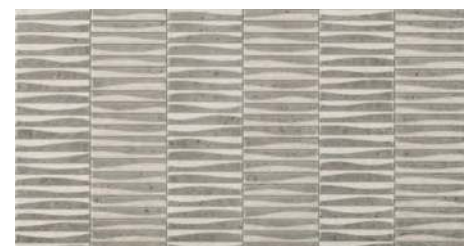

## DECO RODANO

31,6 cm x 59,2 cm x 1,13 cm P2310717 / 100273536 G233

Butech: Colorstuk Rapid n Manhattan B21522248/100236464

**NEW**

DECO RODANO ESTÁ FORMADA POR 3 DECORADOS DISTINTOS ALEATORIOS.  
DECO RODANO IS MADE IN 3 DIFFERENT RANDOM PATTERNS.



## RODANO ACERO

31,6 cm x 59,2 cm x 0,9 cm P2310706 / 100123783 G226

Butech: Colorstuk Rapid n Manhattan B21522248/100236464



## MOSAICO RODANO ACERO

31,6 cm x 59,2 cm x 1,13 cm P2310708 / 100124082 G233

Butech: Colorstuk Rapid n Manhattan B21522248/100236464

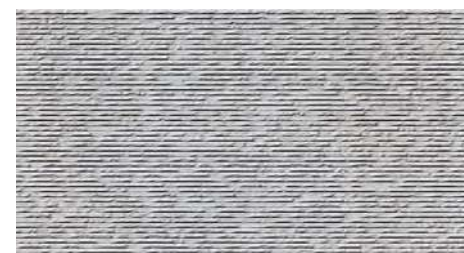

## RODANO LINEAL ACERO

31,6 cm x 59,2 cm x 0,95 cm P2310716 / 100177522 G233

Butech: Colorstuk Rapid n Manhattan B21522248/100236464

# RODANO MOSAICO RODANO RODANO LINEAL

Revestimiento Monoporosa / Wall Tiles



## RODANO CALIZA

31,6 cm x 59,2 cm x 0,9 cm P2310705 / 100123784 G226

Butech: Colorstuk Rapid n Gris B21522258/100236834



## RODANO TAUPE

31,6 cm x 59,2 cm x 0,9 cm P2310704 / 100123785 G226

Butech: Colorstuk Rapid n Gris B21522258/100236834



## MOSAICO RODANO CALIZA

31,6 cm x 59,2 cm x 1,13 cm P2310707 / 100124083 G233

Butech: Colorstuk Rapid n Gris B21522258/100236834



## MOSAICO RODANO TAUPE

31,6 cm x 59,2 cm x 1,13 cm P2310709 / 100124084 G233

Butech: Colorstuk Rapid n Gris B21522258/100236834



## RODANO LINEAL CALIZA

31,6 cm x 59,2 cm x 0,95 cm P2310715 / 100177523 G233

Butech: Colorstuk Rapid n Gris B21522258/100236834

### EMBALAJE / PACKING

MODELO MODEL	PZ/CJ	M2/CJ	*KG/CJ	CJ/PAL	M2/PAL	*KG/PAL	ADHESIVO ADHESIVE BUTECH
31,6 cm x 59,2 cm	6	1,13	15,72	72	81,22	1131,84	Tixocem / One-flex Premium
Deco/Mosaico 31,6cmx59,2cm	5	0,94	14,35	72	67,68	1033,2	
Lineal 31,6 cm x 59,2 cm	6	1,13	17,45	72	81,22	1256,2	

\*valores aproximados. \*approximated values.



PAVIMENTO COMBINABLE: SERIE RODANO 44,3 cm x 44,3 cm  
FLOOR TILES COMBINATIONS: RODANO SERIE 44,3 cm x 44,3 cm





REV. / WALL TILE: RODANO ACERO 51,6 cm x 59,2 cm, MOSAICO RODANO ACERO 51,6 cm x 59,2 cm



# MÁRMOL CARRARA BLANCO

Revestimiento Monoporosa / Wall Tiles

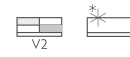

## MÁRMOL CARRARA BLANCO

31,6 cm x 59,2 cm x 0,9 cm P3219300 / 100200370 G226

Butech: Colorstuk Rapid n Blanco B21522247/100236463

# SENA

Revestimiento Monoporosa / Wall Tiles



## SENA ACERO

31,6 cm x 59,2 cm x 0,9 cm P3219310 / 100217829 G226

Butech: Colorstuk Rapid n Manhattan B21522248/100236464



## SENA CALIZA

31,6 cm x 59,2 cm x 0,9 cm P3219314 / 100217850 G226

Butech: Colorstuk Rapid n Gris B21522258/100236834

### EMBALAJE / PACKING

MODELO MODEL	PZ/CJ	M2/CJ	*KG/CJ	CJ/PAL	M2/PAL	*KG/PAL	ADHESIVO ADHESIVE BUTECH
31,6 cm x 59,2 cm	6	1,13	17,25	72	81,22	1242,32	Tixocem + / One-flex Premium

\*valores aproximados. \*approximated values.



PAVIMENTO COMBINABLE: SERIE MÁRMOL CARRARA BLANCO 44,3 cm x 44,3 cm  
FLOOR TILES COMBINATIONS: MARMOL CARRARA BLANCO SERIE 44,3 cm x 44,3 cm

### EMBALAJE / PACKING

MODELO MODEL	PZ/CJ	M2/CJ	*KG/CJ	CJ/PAL	M2/PAL	*KG/PAL	ADHESIVO ADHESIVE BUTECH
31,6 cm x 59,2 cm	6	1,12	18,55	72	81,22	1336,18	Tixocem + / One-flex Premium

\*valores aproximados. \*approximated values.

# CHINA BLANCO OXO DECO BLANCO

Revestimiento Monoporosa / Wall Tiles

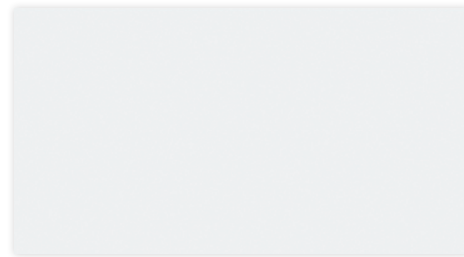

## CHINA BLANCO

31,6 cm x 59,2 cm x 0,9 cm P3219284 / 100157410 G226

Butech: Colorstuk Rapid n Blanco B21522247/100236463



## OXO DECO BLANCO

31,6 cm x 59,2 cm x 1 cm P3219278 / 100157375 G233

Butech: Colorstuk Rapid n Blanco B21522247/100236463



### EMBALAJE / PACKING

MODELO MODEL	PZ/CJ	M2/CJ	*KG/CJ	CJ/PAL	M2/PAL	*KG/PAL	ADHESIVO ADHESIVE BUTECH
31,6 cm x 59,2 cm	6	1,13	17,4	72	81,22	1252,48	Tixocem + / One-flex Premium
Oxo 31,6 cm x 59,2 cm	5	0,94	14,91	72	67,68	1073,47	

\*valores aproximados. \*approximated values.

# GLASS BLANCO

Revestimiento Monoporosa / Wall Tiles



## GLASS BLANCO

31,6 cm x 59,2 cm x 0,9 cm P3219307 / 100217769 G226

Butech: Colorstuk Rapid n Blanco B21522247/100236463

### EMBALAJE / PACKING

MODELO MODEL	PZ/CJ	M2/CJ	*KG/CJ	CJ/PAL	M2/PAL	*KG/PAL	ADHESIVO ADHESIVE BUTECH
31,6 cm x 59,2 cm	6	1,13	17,37	72	81,22	1250,34	Tixocem + / One-flex Premium

\*valores aproximados. \*approximated values.





REV. / WALL TILE: JAPAN BLANCO 31,6 cm x 59,2 cm, JAPAN MARINE 31,6 cm x 59,2 cm \_PAV. / FLOOR TILE: JAPAN BLANCO 44,3 cm x 44,3 cm, JAPAN MARINE 44,3 cm x 44,3 cm

# JAPAN

Revestimiento Monoporosa / Wall Tiles



## JAPAN BLANCO

31,6 cm x 59,2 cm x 0,9 cm P3219273 / 100141159 G226

Butech Colorstuk Rapid n Gris B21522258/100236834

Colorstuk Rapid n Blanco B21522247/100236463



## JAPAN MARINE

31,6 cm x 59,2 cm x 0,9 cm P3219275 / 100141181 G226

Butech: Colorstuk Rapid n Cemento B21522249/100236449

### EMBALAJE / PACKING

MODELO MODEL	PZ/CJ	M2/CJ	*KG/CJ	CJ/PAL	M2/PAL	*KG/PAL	ADHESIVO ADHESIVE BUTECH
31,6 cm x 59,2 cm	6	1,13	17,37	72	81,22	1212,1	Tixocem + / One-flex Premium

\*valores aproximados. \*approximated values.



PAVIMENTO COMBINABLE: SERIE JAPAN 44,3 cm x 44,3 cm  
FLOOR TILES COMBINATIONS: JAPAN SERIE 44,3 cm x 44,3 cm





REV. / WALL TILE: JAMAICA NÁCAR 31,6 cm x 59,2 cm

# KINGSTON JAMAICA

Revestimiento Monoporosa / Wall Tiles



## KINGSTON NÁCAR

31,6 cm x 59,2 cm x 0,9 cm P3219311 / 100217828 G226

Butech: Colorstuk Rapid n Blanco B21522247/100236463



## JAMAICA NÁCAR

31,6 cm x 59,2 cm x 1 cm P3219312 / 100217902 G233

Butech: Colorstuk Rapid n Blanco B21522247/100236463

### EMBALAJE / PACKING

MODELO MODEL	PZ/CJ	M2/CJ	*KG/CJ	CJ/PAL	M2/PAL	*KG/PAL	ADHESIVO ADHESIVE BUTECH
31,6 cm x 59,2 cm	6	1,13	17,37	72	81,22	1250,34	Tixocem + / One-flex Premium

\*valores aproximados. \*approximated values.



# BOTTEGA MARBELLA

Revestimiento Monoporosa / Wall Tiles



**NEW**



**BOTTEGA ACERO**

25 cm x 44,3 cm x 0,98 cm

P3600026 / 100269369 G211

Butech: Colorstuk Rapid n Manhattan B21522248/100236464



**BOTTEGA CALIZA**

25 cm x 44,3 cm x 0,98 cm

P3600027 / 100269408 G211

Butech: Colorstuk Rapid n Gris B21522258/100236834



**MARBELLA STONE**

25 cm x 44,3 cm x 0,98 cm

P3600019 / 100272881 G230

Butech: Colorstuk Rapid n Manhattan B21522248/100236464

MARBELLA ESTÁ FORMADA POR 10 DECORADOS DISTINTOS ALEATORIOS.  
MARBELLA IS MADE IN 10 DIFFERENT RANDOM PATTERNS.

**EMBALAJE / PACKING**

MODELO MODEL	PZ/CJ	M2/CJ	*KG/CJ	CJ/PAL	M2/PAL	*KG/PAL	ADHESIVO ADHESIVE BUTECH
25 cm x 44,3 cm	12	1,32	18,20	68	90,37	1237,87	Tixocem + / One-flex Premium
Marbella 25 cm x 44,3 cm	12	1,32	19,30	68	90,37	1312,94	



PAVIMENTO COMBINABLE: SERIE BOTTEGA 44,3 cm x 44,3 cm  
FLOOR TILES COMBINATIONS: BOTTEGA SERIE 44,3 cm x 44,3 cm

\*valores aproximados. \*approximated values.

# NIMBUS

Revestimiento Monoporosa / Wall Tiles



**NIMBUS BLANCO**

25 cm x 44,3 cm x 0,98 cm

P3600006 / 100273555 G211

Butech: Colorstuk Rapid n Beige B21522252/100236808



**NIMBUS SILVER**

25 cm x 44,3 cm x 0,98 cm

P3600020 / 100273556 G211

Butech: Colorstuk Rapid n Antracita B21522250/100236481

**EMBALAJE / PACKING**

MODELO MODEL	PZ/CJ	M2/CJ	*KG/CJ	CJ/PAL	M2/PAL	*KG/PAL	ADHESIVO ADHESIVE BUTECH
25 cm x 44,3 cm	12	1,32	19,68	68	90,37	1338,24	Tixocem + / One-flex Premium

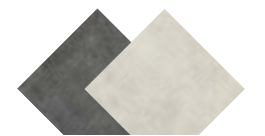

PAVIMENTO COMBINABLE: SERIE NIMBUS 44,3 cm x 44,3 cm  
FLOOR TILES COMBINATIONS: NIMBUS SERIE 44,3 cm x 44,3 cm

\*valores aproximados. \*approximated values.

# PARK PARK LINEAL

Revestimiento Monoporosa / Wall Tiles



## PARK GRIS

25 cm x 44,3 x 0,8 cm

P3600023 / 100269420 G211

Butech: Colorstuk Rapid n Manhattan B21522248/100236464



## PARK BLANCO

25 cm x 44,3 cm x 0,9 cm

P3600024 / 100269396 G211

Butech: Colorstuk Rapid n Gris B21522258/100236834



## PARK LINEAL GRIS

25 cm x 44,3 cm x 0,9 cm

P3600028 / 100269398 G230

Butech: Colorstuk Rapid n Manhattan B21522248/100236464



## PARK LINEAL BLANCO

25 cm x 44,3 cm x 0,9 cm

P3600025 / 100269421 G230

Butech: Colorstuk Rapid n Gris B21522258/100236834

### EMBALAJE / PACKING

MODELO MODEL	PZ/CJ	M2/CJ	*KG/CJ	CJ/PAL	M2/PAL	*KG/PAL	ADHESIVO ADHESIVE BUTECH
25 cm x 44,3 cm	12	1,32	18,20	68	90,37	1237,87	Tixocem + / One-flex Premium
Lineal 25 cm x 44,3 cm	10	1,11	17,30	68	75,31	1174,57	

\*valores aproximados. \*approximated values.

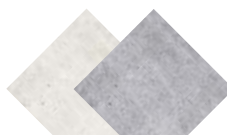

PAVIMENTO COMBINABLE: SERIE PARK 44,3 cm x 44,3 cm  
FLOOR TILES COMBINATIONS: PARK SERIE 44,3 cm x 44,3 cm

# FONTANA

Revestimiento Monoporosa / Wall Tiles



## FONTANA

25 cm x 44,3 cm x 0,9 cm

P3600014 / 100272963 G211

Butech: Colorstuk Rapid n Gris B21522258/100236834

NEW

WALL TILES

### EMBALAJE / PACKING

MODELO MODEL	PZ/CJ	M2/CJ	*KG/CJ	CJ/PAL	M2/PAL	*KG/PAL	ADHESIVO ADHESIVE BUTECH
25 cm x 44,3 cm	12	1,32	19,98	68	90,37	1358,64	Tixocem + / One-flex Premium

\*valores aproximados. \*approximated values.



PAVIMENTO COMBINABLE: SERIE FONTANA MATT 44,3 cm x 44,3 cm  
FLOOR TILES COMBINATIONS: FONTANA MATT SERIE 44,3 cm x 44,3 cm



# MÁLAGA

Revestimiento Monoporosa Brillo / Wall Tiles Gloss



## MÁLAGA AQUA

25 cm x 44,3 cm x 0,93 cm

P3600002 / 100273300 G230

Butech: Colorstuk 0-4 Blanco n B21522237/ 100236442



## MÁLAGA ACERO

25 cm x 44,3 cm x 0,93 cm

P3600021 / 100273258 G230

Butech: Colorstuk 0-4 Blanco n B21522237/ 100236442

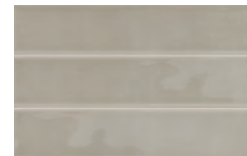

## MÁLAGA BEIGE

25 cm x 44,3 cm x 0,93 cm

P3600010 / 100273310 G230

Butech: Colorstuk 0-4 Blanco n B21522237/ 100236442

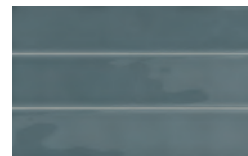

## MÁLAGA OCEAN

25 cm x 44,3 cm x 0,93 cm

P3600000 / 100273301 G230

Butech: Colorstuk 0-4 Blanco n B21522237/ 100236442

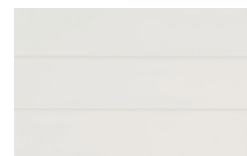

## MÁLAGA WHITE

25 cm x 44,3 cm x 0,93 cm

P3600004 / 100273285 G230

Butech: Colorstuk 0-4 Blanco n B21522237/ 100236442

### EMBALAJE / PACKING

MODELO MODEL	PZ/CJ	M2/CJ	*KG/CJ	CJ/PAL	M2/PAL	*KG/PAL	ADHESIVO ADHESIVE BUTECH
25 cm x 44,3 cm	10	1,10	16,54	68	75,31	1124,72	Tixocem + / One-flex Premium

\*valores aproximados. \*approximated values.

■ IMPORTANTE: Para conseguir una continuidad de las juntas es necesario colocarlo con crucetas de 1mm  
 IMPORTANT: Use 1mm spacers to obtain continuity

# RONDA

Revestimiento Monoporosa / Wall Tiles

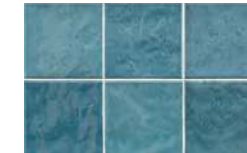

## RONDA AQUA

25 cm x 44,3 cm x 0,93 cm

P3600003 / 100273286 G230

Butech: Colorstuk 0-4 Blanco n B21522237/ 100236442



## RONDA MINT

25 cm x 44,3 cm x 0,93 cm

P3600017 / 100273264 G230

Butech: Colorstuk 0-4 Blanco n B21522237/ 100236442



## RONDA WHITE

25 cm x 44,3 cm x 0,93 cm

P3600009 / 100273259 G230

Butech: Colorstuk 0-4 Blanco n B21522237/ 100236442

### EMBALAJE / PACKING

MODELO MODEL	PZ/CJ	M2/CJ	*KG/CJ	CJ/PAL	M2/PAL	*KG/PAL	ADHESIVO ADHESIVE BUTECH
25 cm x 44,3 cm	10	1,10	16,54	68	75,31	1124,72	Tixocem + / One-flex Premium

\*valores aproximados. \*approximated values.

■ IMPORTANTE: Para conseguir una continuidad de las juntas es necesario colocarlo con crucetas de 1mm  
 IMPORTANT: Use 1mm spacers to obtain continuity

# CHINA BLANCO

Revestimiento Monoporosa / Wall Tiles

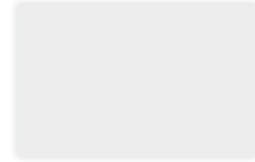

## CHINA BLANCO

25 cm x 44,3 cm x 0,93 cm

P3600018 / 100272939 G211

*Butech: Colorstuk Rapid n Blanco B21522247/100236463*

### EMBALAJE / PACKING

MODELO MODEL	PZ/CJ	M2/CJ	*KG/CJ	CJ/PAL	M2/PAL	*KG/PAL	ADHESIVO ADHESIVE BUTECH
25 cm x 44,3 cm	12	1,32	19,42	68	90,37	1321,10	Tixocem + / One-flex Premium

\*valores aproximados. \*approximated values.

# TECNOS

Revestimiento Monoporosa / Wall Tiles

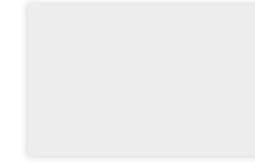

## TECNOS

25 cm x 44,3 cm x 0,93 cm

P3600016 / 100272958 G211

*Butech: Colorstuk Rapid n Blanco B21522247/100236463*

### EMBALAJE / PACKING

MODELO MODEL	PZ/CJ	M2/CJ	*KG/CJ	CJ/PAL	M2/PAL	*KG/PAL	ADHESIVO ADHESIVE BUTECH
25 cm x 44,3 cm	12	1,32	19,42	68	90,37	1321,10	Tixocem + / One-flex Premium

\*valores aproximados. \*approximated values.



# BALI JERSEY

Revestimiento Monoporosa / Wall Tiles



## BALI NIEVE

25 cm x 44,3 cm x 0,93 cm

P3600008 / 100272989 G211

*Butech: Colorstuk 0-4 Blanco n B21522237/ 100236442*



## JERSEY MIX

25 cm x 44,3 cm x 0,93 cm

P3600005 / 100269469 G230

*Butech: Colorstuk Rapid n Gris B21522258/100236834*



### EMBALAJE / PACKING

MODELO MODEL	PZ/CJ	M2/CJ	*KG/CJ	CJ/PAL	M2/PAL	*KG/PAL	ADHESIVO ADHESIVE BUTECH
25 cm x 44,3 cm	12	1,32	19,42	68	90,37	1321,10	Tixocem + / One-flex Premium
Jersey 25 cm x 44,3 cm	10	1,10	16,22	68	75,31	1102,96	

\*valores aproximados. \*approximated values.



PAVIMENTO COMBINABLE: SERIE BALI 44,3 cm x 44,3 cm  
FLOOR TILES COMBINATIONS: BALI SERIE 44,3 cm x 44,3 cm

# JAPAN

Revestimiento Monoporosa / Wall Tiles



## JAPAN BLANCO

25 cm x 44,3 cm x 0,93 cm

P3600015 / 100269468 G211

*Butech Colorstuk Rapid n Gris B21522258/100236834*

*Colorstuk 0-4 Blanco n B21522237/ 100236442*



## JAPAN MARINE

25 cm x 44,3 cm x 0,93 cm

P3600012 / 100273021 G211

*Butech: Colorstuk Rapid n Cemento B21522249/100236449*

### EMBALAJE / PACKING

MODELO MODEL	PZ/CJ	M2/CJ	*KG/CJ	CJ/PAL	M2/PAL	*KG/PAL	ADHESIVO ADHESIVE BUTECH
25 cm x 44,3 cm	12	1,32	19,42	68	90,37	1321,10	Tixocem + / One-flex Premium

\*valores aproximados. \*approximated values.



PAVIMENTO COMBINABLE: SERIE JAPAN 44,3 cm x 44,3 cm  
FLOOR TILES COMBINATIONS: JAPAN SERIE 44,3 cm x 44,3 cm



Los parquets cerámicos han supuesto una gran revolución en el concepto de pavimentos, fusionando el aspecto cálido y distinguido de la madera natural con las ventajas técnicas propias de un material cerámico. PAR-KER ofrece un material gres porcelánico capaz de resistir al desgaste que puede provocar un uso continuado, siendo adecuado incluso para zonas de tránsito medio, como locales de ocio y restauración o ciertas zonas de centros comerciales, donde la demanda de uso no puede ser cubierta por una madera natural.

**PAR-KER®**

*Ceramic parquets have revolutionized the world of flooring, uniting the warm elegance of natural wood with the technical benefits of ceramic tiles. PAR-KER is porcelain flooring able to withstand the wear and tear generated by constant use. It is even suitable for areas subject to medium traffic, such as leisure facilities, catering businesses, or certain areas of shopping centres where natural wood would not perform adequately.*

**PAR-KER®**



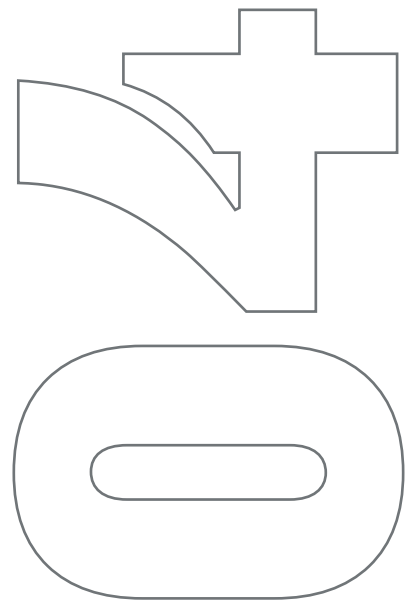

PAR-KER

ASCOT	164
CHESTER	169
DELAWARE	170
FOREST	174
MANHATTAN	178
NOBU	182
ORLEANS	186
OXFORD	190

ATELIER

HERITAGE	195
----------	-----

# ASCOT

Gres Porcellanato Rectificado · Color Masa / Rectified Porcellanato Tiles · Colored Biscuit



### ASCOT ARCE

29,4 cm x 120 cm x 1,1 cm P1876038 / 100161044 G384  
 19,3 cm x 120 cm x 1,1 cm P1880286 / 100161043 G384

*Butech: Colorstuk Especial Oak B21522235/100204255*

### ASCOT ARCE ANTISLIP

19,3 cm x 120 cm x 1,1cm P1880287 / 100161045 G384

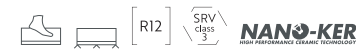

### EMBALAJE / PACKING

MODELO MODEL	PZ/CJ	M2/CJ	*KG/CJ	CJ/PAL	M2/PAL	*KG/PAL	ADHESIVO ADHESIVE BUTECH
29,4 cm x 120cm	3	1,06	29,2	40	42,33	1169	One-flex Premium / Super-flex s2
19,3 cm x 120 cm	5	1,16	31,73	48	55,58	1523	
Zócalo 10 cm x 44,3 cm	20	0,89	18,80	68	60,25	1278,40	
HT 29,4 cm x 120 cm	2	0,68	17,48	28	19,15	489,53	
HTE 29,4 cm x 120 cm	1	0,43	10,34	26	10,48	268,74	

\*valores aproximados. \*approximated values.

# ASCOT

Gres Porcellanato Rectificado · Color Masa / Rectified Porcellanato Tiles · Colored Biscuit



### ASCOT TECA

29,4 cm x 120 cm x 1,1 cm P1876040 / 100161123 G384  
 19,3 cm x 120 cm x 1,1 cm P1880295 / 100161038 G384

*Butech: Colorstuk Especial Doussie B21522233/100204260*

### ASCOT TECA ANTISLIP

19,3 cm x 120 cm x 1,1cm P1880294 / 100161039 G384

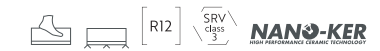

### HUELLA TÉCNICA / STEP TILES

MODELO MODEL	29,4 cm x 120 cm			ESQUINA DE. / R. CORNER			ESQUINA IZ. / L. CORNER		
ASCOT TECA	P1876063 / 100178670	G171		P1876064 / 100178680	G185		P1876075 / 100178684	G185	
ASCOT TECA ANT.	P1876058 / 100178627	G171		P1876065 / 100178681	G185		P1876076 / 100178663	G185	
ASCOT ARCE	P1876056 / 100178646	G171		P1876074 / 100178656	G185		P1876066 / 100178672	G185	
ASCOT ARCE ANT.	P1876055 / 100178637	G171		P1876077 / 100178675	G185		P1876067 / 100178653	G185	

### ZÓCALO / SKIRTING BOARDS

MODELO MODEL	9,5 cm x 120 cm			10 cm x 44,3 cm			PRO-SKIRTING 10 cm x 180 cm	CORTE 9,5 cm
ASCOT TECA	P9201799 / 100229659	G78		P8270058 / 100146783	G11		B71142029 / 100178466	x 120 cm G72
ASCOT ARCE	P9201804 / 100229799	G78		P8270060 / 100146779	G11		B71142022 / 100178480	x 120 cm G72









PAV. / FLOOR TILE: CHESTER LEÑO 22 cm x 90 cm

# CHESTER

Gres Porcellanato Rectificado · Color Masa / Rectified Porcellanato Tiles · Colored Biscuit

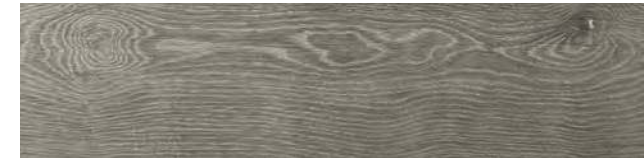

**CHESTER LEÑO**  
22 cm x 90 cm x 1,1 cm P1140040 / 100155609 G372  
Butech: Colorstuk Rapid n Cemento B21522249/100236449



**CHESTER ACERO**  
22 cm x 90 cm x 1,1 cm P1140041 / 100155601 G372  
Butech: Colorstuk Rapid n Manhattan B21522248/100236464

## EMBALAJE / PACKING

MODELO MODEL	PZ/CJ	M2/CJ	*KG/CJ	CJ/PAL	M2/PAL	*KG/PAL	ADHESIVO ADHESIVE BUTECH
22 cm x 90 cm	6	1,19	30	52	61,78	1510	Fr-one n / One-flex Premium
Zócalo 10 cm x 44,3 cm	20	0,89	18,80	68	60,25	1252,56	
HT 31,6 cm x 90 cm	2	0,63	17,08	26	16,33	446,68	
HTE 31,6 cm x 90 cm	1	0,31	8,54	26	8,17	223,31	

\*valores aproximados. \*approximated values.

## HUELLA TÉCNICA / STEP TILES

MODELO MODEL	31,6 cm x 90 cm	ESQUINA DE. / R. CORNER	ESQUINA IZ. / L. CORNER
CHESTER LEÑO	P8660157 / 100156506 G146	P8660163 / 100156701 G172	P8660167 / 100156664 G172
CHESTER ACERO	P8660153 / 100156502 G146	P8660158 / 100156663 G172	P8660162 / 100156702 G172

## ZÓCALO / SKIRTING BOARDS

MODELO MODEL	10 cm x 44,3 cm
CHESTER LEÑO	P8270067 / 100156532 G11
CHESTER ACERO	P8270065 / 100156508 G11



# DELAWARE

Gres Porcellanato Rectificado · Color Masa / Rectified Porcellanato Tiles · Colored Biscuit



## DELAWARE NATURAL

29,4 cm x 180 cm x 1,2 cm	P1680054 / 100214666	G386
19,3 cm x 180 cm x 1,2 cm	P1670042 / 100214732	G386
29,4 cm x 120 cm x 1,1 cm	P1876187 / 100214715	G384
19,3 cm x 120 cm x 1,1 cm	P1880345 / 100214776	G384

Butech: Colorstuk Especial Maple B51201055/100243271

## DELAWARE NATURAL ANTISLIP

19,3 cm x 180 cm x 1,15 cm	P1670043 / 100214721	G386
----------------------------	----------------------	------

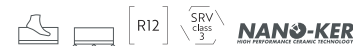

## EMBALAJE / PACKING

MODELO MODEL	PZ/CJ	M2/CJ	*KG/CJ	CJ/PAL	M2/PAL	*KG/PAL	ADHESIVO ADHESIVE BUTECH
29,4 cm x 180cm	2	1,06	31,11	50	52,92	1555,3	One-flex Premium / Super-flex s2
19,3 cm x 180 cm	3	1,04	29,97	54	56,28	1618,4	
29,4 cm x 120cm	3	1,06	29,05	40	42,34	1161,96	
19,3 cm x 120 cm	5	1,16	31,75	48	55,58	1524,48	
Zócalo 9,5 cm x 180 cm	6	1,03	28,53	28	28,73	798,93	
Zócalo 9,5 cm x 120 cm	6	0,68	17,48	28	17,48	489,53	
HT 29,4 cm x 120 cm	2	0,78	20,67	26	20,4	537,74	
HTE 29,4 cm x 120 cm	1	0,4	10,34	26	10,48	268,74	

\*valores aproximados. \*approximated values.

# DELAWARE

Gres Porcellanato Rectificado · Color Masa / Rectified Porcellanato Tiles · Colored Biscuit



## DELAWARE NOGAL

29,4 cm x 180 cm x 1,2 cm	P1680052 / 100214616	G386
19,3 cm x 180 cm x 1,2 cm	P1670035 / 100214599	G386
29,4 cm x 120 cm x 1,1 cm	P1876185 / 100214569	G384
19,3 cm x 120 cm x 1,1 cm	P1880341 / 100214655	G384

Butech: Colorstuk Especial Doussie B21522233/100204260

## DELAWARE NOGAL ANTISLIP

19,3 cm x 180 cm x 1,15 cm	P1670034 / 100214625	G386
----------------------------	----------------------	------

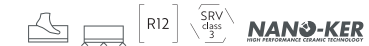

## HUELLA TÉCNICA / STEP TILES



MODELO MODEL	29,4 cm x 120 cm		ESQUINA DE. / R. CORNER		ESQUINA IZ. / L. CORNER	
DELAWARE NOGAL	P1876190 / 100217912	G171	P1876192 / 100217925	G185	P1876195 / 100217901	G185
D. NOGAL ANT.	P1876191 / 100217875	G171	P1876194 / 100217893	G185	P1876193 / 100217881	G185
DELAWARE NATURAL	P1876218 / 100219167	G171	P1876204 / 100219221	G185	P1876210 / 100219197	G185
D. NATURAL ANT.	P1876219 / 100219198	G171	P1876201 / 100219179	G185	P1876211 / 100219185	G185
	29,4 cm x 180 cm	G193		G196		G196

## ZÓCALO / SKIRTING BOARDS



MODELO MODEL	9,5 cm x 180 cm		9,5 cm x 120 cm		PRO-SKIRTING 10 cm x 180 cm	CORTE 9,5 cm
DELAWARE NOGAL	P9201925 / 100233650	G89	P9201906 / 100233144	G78	B79999077 / 100222027	x 180 cm G88 _ x 120 cm G72
DELAWARE NATURAL	P9201786 / 100227179	G89	P9201957 / 100234991	G78	B79999076 / 100222010	x 180 cm G88 _ x 120 cm G72





PAV. / FLOOR TILE: DELAWARE NATURAL. 29,4 cm x 180 cm / 19,3 cm x 180 cm



# FOREST

Gres Porcellanato Rectificado · Color Masa / Rectified Porcellanato Tiles · Colored Biscuit



**FOREST COGNAC**

22 cm x 90 cm x 1,1 cm	P1140072 / 100234777	G340
14,3 cm x 90 cm x 1,1 cm	P1780099 / 100234776	G340

**FOREST COGNAC ANTISLIP**

14,3 cm x 90 cm x 1,1 cm	P1780100 / 100234749	G340
--------------------------	----------------------	------

*Butech: Colorstuk Especial Doussie B21522233/100204260*

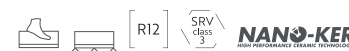

**FOREST MAPLE**

22 cm x 90 cm x 1,1 cm	P1140070 / 100234778	G340
14,3 cm x 90 cm x 1,1 cm	P1780101 / 100234795	G340

**FOREST MAPLE ANTISLIP**

14,3 cm x 90 cm x 1,1 cm	P1780104 / 100234796	G340
--------------------------	----------------------	------

*Butech: Colorstuk Especial Elm B24302052/100234451*



CONTENIDO EN MATERIAL RECICLADO >95%  
CONTENT IN RECYCLED MATERIAL >95%

# FOREST

Gres Porcellanato Rectificado · Color Masa / Rectified Porcellanato Tiles · Colored Biscuit



**FOREST ACERO**

22 cm x 90 cm x 1,1 cm	P1140069 / 100226122	G340
14,3 cm x 90 cm x 1,1 cm	P1780094 / 100226120	G340

**FOREST ACERO ANTISLIP**

14,3 cm x 90 cm x 1,1 cm	P1780097 / 100226107	G340
--------------------------	----------------------	------

*Butech: Colorstuk Especial Ash B21522231/100204245*

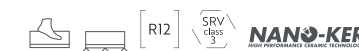

**FOREST FRESNO**

22 cm x 90 cm x 1,1 cm	P1140065 / 100226140	G340
14,3 cm x 90 cm x 1,1 cm	P1780093 / 100226109	G340

**FOREST FRESNO ANTISLIP**

14,3 cm x 90 cm x 1,1 cm	P1780095 / 100226116	G340
--------------------------	----------------------	------

*Butech: Colorstuk Rapid n Gris B21522258/100236834*

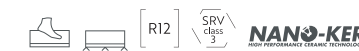

**FOREST ARCE**

22 cm x 90 cm x 1,1 cm	P1140066 / 100225554	G340
14,3 cm x 90 cm x 1,1 cm	P1780090 / 100226132	G340

**FOREST ARCE ANTISLIP**

14,3 cm x 90 cm x 1,1 cm	P1780092 / 100226133	G340
--------------------------	----------------------	------

*Butech: Colorstuk Especial Maple B51201055/100243271*



**FOREST NATURAL**

22 cm x 90 cm x 1,1 cm	P1140068 / 100225538	G340
14,3 cm x 90 cm x 1,1 cm	P1780098 / 100226112	G340

**FOREST NATURAL ANTISLIP**

14,3 cm x 90 cm x 1,1 cm	P1780091 / 100225539	G340
--------------------------	----------------------	------

*Butech: Colorstuk Especial Iroko B51201054/100243281*



CONTENIDO EN MATERIAL RECICLADO >95%  
CONTENT IN RECYCLED MATERIAL >95%



## EMBALAJE / PACKING

MODELO MODEL	PZ/CJ	M2/CJ	*KG/CJ	CJ/PAL	M2/PAL	*KG/PAL	ADHESIVO ADHESIVE BUTECH
22 cm x 90cm	6	1,19	30	52	61,78	1510	Fr-one n / One-flex Premium
14,3 cm x 90 cm	8	1,03	26	60	61,78	1514	
Zócalo 10 cm x 44,3 cm	20	0,89	19	68	60,25	1292	
HT 31,6 cm x 90 cm	2	0,63	17,3	26	16,33	460,98	
HTE 31,6 cm x 90 cm	1	0,33	8,87	26	8,47	230,49	

\*valores aproximados. \*approximated values.

## HUELLA TÉCNICA / STEP TILES

MODELO MODEL	31,6 cm x 90 cm	ESQUINA DE. / R. CORNER	ESQUINA IZ. / L. CORNER
FOREST NATURAL	P8660245 / 100227360 G144	P8660215 / 100227309 G169	P8660226 / 100227319 G169
F. NATURAL ANT.	P8660213 / 100227329 G144	P8660225 / 100227334 G169	P8660244 / 100227350 G169
FOREST ACERO	P8660229 / 100227333 G144	P8660220 / 100227323 G169	P8660234 / 100227306 G169
F. ACERO ANT.	P8660233 / 100227297 G144	P8660221 / 100227317 G169	P8660242 / 100227340 G169
FOREST FRESNO	P8660239 / 100227299 G144	P8660217 / 100227308 G169	P8660232 / 100227307 G169
F. FRESNO ANT.	P8660230 / 100227328 G144	P8660240 / 100227298 G169	P8660235 / 100227343 G169
FOREST ARCE	P8660214 / 100227342 G144	P8660222 / 100227341 G169	P8660241 / 100227325 G169
F. ARCE ANT.	P8660223 / 100227327 G144	P8660219 / 100227318 G169	P8660218 / 100227326 G169
FOREST COGNAC	P8660264 / 100238375 G144	P8660003 / 100121683 G169	P8660252 / 100238373 G169
F. COGNAC ANT.	P8660263 / 100238398 G144	P8660250 / 100238258 G169	P8660253 / 100238401 G169
FOREST COLONIAL	P8660265 / 100238259 G144	P8660261 / 100238396 G169	P8660256 / 100238384 G169
F. COLONIAL ANT.	P8660254 / 100238393 G144	P8660257 / 100238397 G169	P8660260 / 100238374 G169
FOREST MAPLE	P8660255 / 100238394 G144	P8660262 / 100238402 G169	P8660266 / 100238399 G169
F. MAPLE ANT.	P8660251 / 100238383 G144	P8660258 / 100238386 G169	P8660267 / 100238420 G169

## ZÓCALO / SKIRTING BOARDS

MODELO MODEL	10 cm x 44,3 cm
FOREST ACERO	P8270081 / 100227310 G11
FOREST ARCE	P8270084 / 100227288 G11
FOREST FRESNO	P8270082 / 100227289 G11
FOREST NATURAL	P8270085 / 100227259 G11
FOREST COGNAC	P8270086 / 100238430 G11
FOREST COLONIAL	P8270088 / 100238405 G11
FOREST MAPLE	P8270087 / 100238434 G11



**FOREST**  
*Ecologic Ceramic*



# MANHATTAN

Gres Porcellanato Rectificado · Color Masa / Rectified Porcellanato Tiles · Colored Biscuit



## MANHATTAN COGNAC

29,4 cm x 180 cm x 1,2 cm	P1680020 / 100190048	G386
19,3 cm x 180 cm x 1,2 cm	P1670025 / 100190050	G386
29,4 cm x 120 cm x 1,1 cm	P1876117 / 100190034	G384
19,3 cm x 120 cm x 1,1 cm	P1880325 / 100190027	G384

Butech: Colorstuk Especial Doussie B2152233/100204260

## MANHATTAN COGNAC ANTISLIP

19,3 cm x 180 cm x 1,2cm	P1670019 / 100190054	G386
--------------------------	----------------------	------

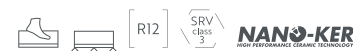

# MANHATTAN

Gres Porcellanato Rectificado · Color Masa / Rectified Porcellanato Tiles · Colored Biscuit



## MANHATTAN COLONIAL

29,4 cm x 180 cm x 1,2 cm	P1680022 / 100190061	G386
19,3 cm x 180 cm x 1,2 cm	P1670020 / 100190055	G386
29,4 cm x 120 cm x 1,1 cm	P1876116 / 100190052	G384
19,3 cm x 120 cm x 1,1 cm	P1880329 / 100190042	G384

Butech: Colorstuk Especial Elm B24302052/100234451

## MANHATTAN COLONIAL ANTISLIP

19,3 cm x 180 cm x 1,2cm	P1670024 / 100190062	G386
--------------------------	----------------------	------



## MANHATTAN MAPLE

29,4 cm x 180 cm x 1,2 cm	P1680019 / 100190039	G386
19,3 cm x 180 cm x 1,2 cm	P1670016 / 100190038	G386
29,4 cm x 120 cm x 1,1 cm	P1876119 / 100190060	G384
19,3 cm x 120 cm x 1,1 cm	P1880326 / 100190043	G384

Butech: Colorstuk Especial Elm B24302052/100234451

## MANHATTAN MAPLE ANTISLIP

19,3 cm x 180 cm x 1,2cm	P1670023 / 100190071	G386
--------------------------	----------------------	------





**EMBALAJE / PACKING**

MODELO MODEL	PZ/CJ	M2/CJ	*KG/CJ	CJ/PAL	M2/PAL	*KG/PAL	ADHESIVO ADHESIVE BUTECH
29,4 cm x 180cm	2	1,06	29,48	50	52,92	1474	One-flex Premium / Super-flex s2
19,3 cm x 180 cm	3	1,04	29,17	54	56,28	1575	
29,4 cm x 120cm	3	1,06	28,29	40	42,34	1132	
19,3 cm x 120 cm	5	1,16	30,79	48	55,58	1524	
Zócalo 9,5 cm x 180 cm	6	1,03	28,53	28	28,73	798,93	
Zócalo 9,5 cm x 120 cm	6	0,68	17,48	28	19,15	489,53	
HT 29,4 cm x 120 cm	2	0,78	20,80	26	20,4	541	
HTE 29,4 cm x 120 cm	1	0,4	10,40	26	10,48	270,37	

\*valores aproximados. \*approximated values.

**HUELLA TÉCNICA / STEP TILES**

MODELO MODEL	29,4 cm x 120 cm		ESQUINA DE. / R. CORNER		ESQUINA IZ. / L. CORNER	
MANHATTAN COGNAC	P1876149 / 100191335	G171	P1876141 / 100191269	G185	P1876145 / 100191341	G185
M. COGNAC ANT.	P1876151 / 100191360	G171	P1876142 / 100191294	G185	P1876146 / 100191323	G185
MANHATTAN MAPLE	P1876150 / 100191351	G171	P1876144 / 100191309	G185	P1876147 / 100191345	G185
M. MAPLE ANT.	P1876152 / 100191336	G171	P1876143 / 100191299	G185	P1876148 / 100191332	G185
MANHATTAN COLONIAL	P1876130 / 100191061	G171	P1876127 / 100191038	G185	P1876128 / 100191027	G185
M. COLONIAL ANT.	P1876132 / 100191071	G171	P1876129 / 100191026	G185	P1876131 / 100191060	G185
	29,4 cm x 180 cm	G193		G196		G196

**ZÓCALO / SKIRTING BOARDS**

MODELO MODEL	9,5 cm x 180 cm		9,5 cm x 120 cm		PRO-SKIRTING 10 cm x 180 cm	CORTE 9,5 cm
MANHATTAN COGNAC	P9201374 / 100206795	G89	P9201393 / 100208774	G78	B79999016 / 100191470	x 180 cm G88 _ x 120 cm G72
MANHATTAN COLONIAL	P9201326 / 100201667	G89	P9201325 / 100201698	G78	B79999020 / 100189248	x 180 cm G88 _ x 120 cm G72
MANHATTAN MAPLE	P9201312 / 100201029	G89	P9201530 / 100211022	G78	B79999017 / 100191461	x 180 cm G88 _ x 120 cm G72





# NOBU

Gres Porcellanato Rectificado · Color Masa / Rectified Porcellanato Tiles · Colored Biscuit



## NOBU ARCE

29,4 cm x 180 cm x 1,15 cm P1680080 / 100240011 G386  
19,3 cm x 180 cm x 1,15 cm P1670059 / 100240770 G386

Butech: Colorstuk Especial Elm B24302052/100234451

## NOBU ARCE ANTISLIP

19,3 cm x 180 cm x 1,15 cm P1670057 / 100240780 G386

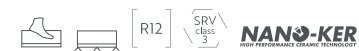

## EMBALAJE / PACKING

MODELO MODEL	PZ/CJ	M2/CJ	*KG/CJ	CJ/PAL	M2/PAL	*KG/PAL	ADHESIVO ADHESIVE BUTECH
29,4 cm x 180cm	2	1,06	29,48	50	52,92	1474	One-flex Premium / Super-flex s2
19,3 cm x 180 cm	3	1,04	29,17	54	56,28	1574,96	
Zócalo 9,5 cm x 180 cm	6	1,03	28,71	28	28,73	803,88	
HT 29,4 cm x 180 cm	1	0,59	14,74	36	21,19	530,64	
HTE 29,4 cm x 180 cm	1	0,6	14,74	36	21,58	530,64	

\*valores aproximados. \*approximated values.

# NOBU

Gres Porcellanato Rectificado · Color Masa / Rectified Porcellanato Tiles · Colored Biscuit



## NOBU ROBLE

29,4 cm x 180 cm x 1,15 cm P1680077 / 100240004 G386  
19,3 cm x 180 cm x 1,15 cm P1670058 / 100240781 G386

Butech: Colorstuk Rapid n Tabaco B21522255/100236823

## NOBU ROBLE ANTISLIP

19,3 cm x 180 cm x 1,15 cm P1857106 / 100240755 G386



## HUELLA TÉCNICA / STEP TILES

MODELO MODEL	29,4 cm x 180 cm	ESQUINA DE. / R. CORNER	ESQUINA IZ. / L. CORNER
NOBU ARCE	P1680092 / 100242297 G193	P1680091 / 100242295 G196	P1680082 / 100242266 G196
NOBU ARCE ANT.	P1680089 / 100242331 G193	P1680090 / 100242312 G196	P1680084 / 100242292 G196
NOBU ROBLE	P1680086 / 100242298 G193	P1680088 / 100242306 G196	P1680093 / 100242304 G196
NOBU ROBLE ANT.	P1680087 / 100242323 G193	P1680083 / 100242285 G196	P1680085 / 100242267 G196
	29,4 cm x 120 cm G171	G185	G185

## ZÓCALO / SKIRTING BOARDS

MODELO MODEL	9,5 cm x 180 cm	PRO-SKIRTING 10 cm x 180 cm	CORTE 9,5 cm
NOBU ARCE	P9202203 / 100242354 G89	B70104255 / 100243412	x 180 cm G88
NOBU ROBLE	P9202202 / 100242374 G89	B70104256 / 100243420	x 180 cm G88







# ORLEANS

Gres Porcellanato Rectificado · Color Masa / Rectified Porcellanato Tiles · Colored Biscuit



## ORLEANS ARCE

19,3 cm x 120 cm x 1,1 cm

P1880355 / 100242763 G387

*Butech: Colorstuk Especial Oak B21522235/100204255*

## ORLEANS ARCE ANTISLIP

19,3 cm x 120 cm x 1,1 cm

P1880357 / 100243010 G387



## ORLEANS GREY

19,3 cm x 120 cm x 1,1 cm

P1880356 / 100242745 G387

*Butech: Colorstuk Rapid n Cemento B21522249/100236449*

## ORLEANS GREY ANTISLIP

19,3 cm x 120 cm x 1,1 cm

P1880359 / 100242988 G387



# ORLEANS

Gres Porcellanato Rectificado · Color Masa / Rectified Porcellanato Tiles · Colored Biscuit



## ORLEANS NATURAL

19,3 cm x 120 cm x 1,1 cm

P1880354 / 100242772 G387

*Butech: Colorstuk Especial Oak B21522235/100204255*

## ORLEANS NATURAL ANTISLIP

19,3 cm x 120 cm x 1,1 cm

P1880361 / 100242969 G387



## ORLEANS NUT

19,3 cm x 120 cm x 1,1 cm

P1880352 / 100242753 G387

*Butech: Colorstuk Rapid n Moka: B21522260/100236824*

## ORLEANS NUT ANTISLIP

19,3 cm x 120 cm x 1,1 cm

P1880360 / 100242993 G387

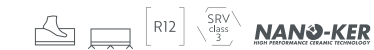

## ORLEANS ROBLE

19,3 cm x 120 cm x 1,1 cm

P1880353 / 100242746 G387

*Butech: Colorstuk Especial Iroko B51201054/100243281*

## ORLEANS ROBLE ANTISLIP

19,3 cm x 120 cm x 1,1 cm

P1880358 / 100243001 G387





**EMBALAJE / PACKING**

MODELO / MODEL	PZ/CJ	M2/CJ	*KG/CJ	CJ/PAL	M2/PAL	*KG/PAL	ADHESIVO / ADHESIVE BUTECH
19,3 cm x 120 cm	5	1,16	31,75	48	55,58	1524,48	One-flex Premium / Super-flex s2
Zócalo 9,5 cm x 120 cm	6	0,68	19,14	28	19,15	535,92	
HT 29,4 cm x 120 cm	2	0,79	22,22	26	21,78	577,7	
HTE 29,4 cm x 120 cm	1	0,4	10,56	26	11,19	292,2	

\*valores aproximados. \*approximated values.

**HUELLA TÉCNICA / STEP TILES**



MODELO / MODEL	29,4 cm x 120 cm		ESQUINA DE. / R. CORNER		ESQUINA IZ. / L. CORNER	
ORLEANS GREY	P1876253 / 100242961	G171	P1876256 / 100242933	G185	P1876263 / 100242964	G185
O. GREY ANT.	P1876274 / 100242975	G171	P1876278 / 100242899	G185	P1876270 / 100242986	G185
ORLEANS ROBLE	P1876258 / 100242952	G171	P1876261 / 100242970	G185	P1876254 / 100242928	G185
O. ROBLE ANT.	P1876268 / 100242976	G171	P1876275 / 100242967	G185	P1876277 / 100242974	G185
ORLEANS NUT	P1876255 / 100242951	G171	P1876265 / 100242955	G185	P1876257 / 100242957	G185
O. NUT ANT.	P1876272 / 100242984	G171	P1876269 / 100242985	G185	P1876267 / 100242991	G185
ORLEANS ARCE	P1876262 / 100242960	G171	P1876259 / 100242931	G185	P1876264 / 100242971	G185
O. ARCE ANT.	P1876273 / 100242937	G171	P1876276 / 100242936	G185	P1876281 / 100242939	G185
ORLEANS NATURAL	P1876252 / 100242932	G171	P1876260 / 100242963	G185	P1876266 / 100242956	G185
O. NATURAL ANT.	P1876280 / 100242938	G171	P1876271 / 100242990	G185	P1876279 / 100242946	G185

**ZÓCALO / SKIRTING BOARDS**



MODELO / MODEL	9,5 cm x 120 cm	PRO-SKIRTING 10 cm x 180 cm	CORTE 9,5 cm
ORLEANS GREY	P9202272 / 100242953	G78	B70104253 / 100243409
ORLEANS ROBLE	P9202271 / 100242942	G78	B70104268 / 100243453
ORLEANS NUT	P9202269 / 100242897	G78	B70104266 / 100243425
ORLEANS ARCE	P9202270 / 100242962	G78	B70104263 / 100243443
ORLEANS NATURAL	P9202268 / 100242954	G78	B70104265 / 100243446





# OXFORD

Gres Porcellanato Rectificado · Color Masa / Rectified Porcellanato Tiles · Colored Biscuit



## OXFORD ACERO

22 cm x 90 cm x 1,1 cm	P1140001 / 100104705	G372
14,3 cm x 90 cm x 1,1 cm	P1780001 / 100104696	G372

## OXFORD ACERO ANTISLIP

14,3 cm x 90 cm x 1,2 cm	P1780004 / 100105007	G372
--------------------------	----------------------	------

Butech: Colorstuk Rapid n Manhattan B21522248/100236464



## OXFORD BLANCO

22 cm x 90 cm x 1,1 cm	P1140006 / 100105234	G372
14,3 cm x 90 cm x 1,1 cm	P1780012 / 100105233	G372

## OXFORD BLANCO ANTISLIP

14,3 cm x 90 cm x 1,1 cm	P1780010 / 10010523	G372
--------------------------	---------------------	------

Butech: Colorstuk Rapid n Gris B21522258/100236834



\*Para la confección del acabado antislip y con el objetivo de mejorar las propiedades higiénicas, se han eliminado las imágenes más claras de la serie original.

\*For the preparation of the antislip finish and to improve the hygienic properties, the clearest images of the original range have been removed.



## OXFORD ANTRACITA

22 cm x 90 cm x 1,1 cm	P1140000 / 100104706	G372
14,3 cm x 90 cm x 1,1 cm	P1780000 / 100104697	G372

## OXFORD ANTRACITA ANTISLIP

14,3 cm x 90 cm x 1,2 cm	P1780003 / 100105008	G372
--------------------------	----------------------	------

Butech: Colorstuk Rapid n Moka B24302056/100238261

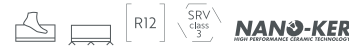

## OXFORD COGNAC

22 cm x 90 cm x 1,1 cm	P1140013 / 100115861	G372
14,3 cm x 90 cm x 1,1 cm	P1780022 / 100115860	G372

## OXFORD COGNAC ANTISLIP

14,3 cm x 90 cm x 1,2 cm	P1780023 / 100115862	G372
--------------------------	----------------------	------

Butech: Colorstuk Rapid n Tabaco B21522255/100236823



## OXFORD SILVER

22 cm x 90 cm x 1,1 cm	P1140009 / 100113365	G372
14,3 cm x 90 cm x 1,1 cm	P1780015 / 100113364	G372

## OXFORD SILVER ANTISLIP

14,3 cm x 90 cm x 1,2 cm	P1780016 / 100113366	G372
--------------------------	----------------------	------

Butech: Colorstuk Rapid n Cemento B21522249/100236449



# OXFORD

Gres Porcellanato Rectificado · Color Masa / Rectified Porcellanato Tiles · Colored Biscuit



## OXFORD NATURAL

22 cm x 90 cm x 1,1 cm	P1140016 / 100127105	G372
14,3 cm x 90 cm x 1,1 cm	P1780026 / 100127104	G372

## OXFORD NATURAL ANTISLIP

14,3 cm x 90 cm x 1,1 cm	P1780028 / 100130896	G372
--------------------------	----------------------	------

Butech: Colorstuk Especial Honey B21522234/100204261



## OXFORD CASTAÑO

22 cm x 90 cm x 1,1 cm	P1140002 / 100105010	G372
14,3 cm x 90 cm x 1,1 cm	P1780002 / 100105009	G372

## OXFORD CASTAÑO ANTISLIP

14,3 cm x 90 cm x 1,2 cm	P1780005 / 100105011	G372
--------------------------	----------------------	------

Butech: Colorstuk Rapid n Moka B24302056/100238261





**EMBALAJE / PACKING**

MODELO MODEL	PZ/CJ	M2/CJ	*KG/CJ	CJ/PAL	M2/PAL	*KG/PAL	ADHESIVO ADHESIVE BUTECH
22 cm x 90cm	6	1,19	30	52	61,78	1510	Fr-one n / One-flex Premium
14,3 cm x 90 cm	8	1,03	26	60	61,78	1514	
Zócalo 10 cm x 44,3 cm	20	0,89	18,80	68	60,25	1278,40	
HT 31,6 cm x 90 cm	2	0,63	17,08	26	16,33	443,96	
HTE 31,6 cm x 90 cm	1	0,31	8,54	26	8,17	222	

\*valores aproximados. \*approximated values.

**HUELLA TÉCNICA / STEP TILES**



MODELO MODEL	31,6 cm x 90 cm	ESQUINA DE. / R. CORNER	ESQUINA IZ. / L. CORNER
OXFORD ACERO	P8660011 / 100122057 G146	P8660073 / 100123033 G172	P8660068 / 100123054 G172
O. ACERO ANT.	P8660007 / 100121849 G146	P8660079 / 100123034 G172	P8660067 / 100123055 G172
OXFORD ANTRACITA	P8660012 / 100122058 G146	P8660069 / 100123035 G172	P8660066 / 100123056 G172
O. ANTRACITA ANT.	P8660013 / 100122059 G146	P8660080 / 100123036 G172	P8660071 / 100123057 G172
OXFORD BLANCO	P8660014 / 100122060 G146	P8660032 / 100122193 G172	P8660075 / 100123058 G172
O. BLANCO ANT.	P8660016 / 100122061 G146	P8660077 / 100123037 G172	P8660072 / 100123059 G172
OXFORD CASTAÑO	P8660019 / 100122062 G146	P8660064 / 100123038 G172	P8660034 / 100122777 G172
O. CASTAÑO ANT.	P8660000 / 100121360 G146	P8660076 / 100123039 G172	P8660074 / 100123060 G172
OXFORD COGNAC	P8660002 / 100121685 G146	P8660003 / 100121683 G172	P8660001 / 100121684 G172
O. COGNAC ANT.	P8660006 / 100121834 G146	P8660004 / 100121832 G172	P8660005 / 100121833 G172
OXFORD NATURAL	P8660089 / 100136280 G146	P8660096 / 100136272 G172	P8660085 / 100136276 G172
O. NATURAL ANT.	P8660094 / 100136281 G146	P8660091 / 100136273 G172	P8660095 / 100136277 G172
OXFORD SILVER	P8660015 / 100122063 G146	P8660065 / 100123040 G172	P8660078 / 100123061 G172
O. SILVER ANT.	P8660018 / 100122064 G146	P8660070 / 100123041 G172	P8660063 / 100123062 G172

**ZÓCALO / SKIRTING BOARDS**



MODELO MODEL	10 cm x 44,3 cm	PRO-SKIRTING 10 cm x 180 cm
OXFORD ACERO	P8270031 / 100124211 G11	B71142020 / 100178475
OXFORD ANTRACITA	P8270034 / 100124231 G11	B71142031 / 100178471
OXFORD BLANCO	P8270036 / 100124232 G11	B71142013 / 100178436
OXFORD CASTAÑO	P8270042 / 100127005 G11	B71142015 / 100178435
OXFORD COGNAC	P8270051 / 100139710 G11	B71142012 / 100178437
OXFORD NATURAL	P8270049 / 100136284 G11	B71142023 / 100178462
OXFORD SILVER	P8270037 / 100124233 G11	B71142028 / 100178463



PAV. / FLOOR TILE: OXFORD ANTRACITA ANTIBLIP 14,3 cm x 90 cm





PAV. / FLOOR TILE: HERITAGE COLONIAL 80 cm x 80 cm

# HERITAGE

Gres Porcellanato Rectificado · Color Masa / Rectified Porcellanato Tiles · Colored Biscuit



## HERITAGE COGNAC

80 cm x 80 cm x 1,1 cm P1760112 / 100190915 G373

Butech: Colorstuk Rapid n Tabaco B21522255/100236823



## HERITAGE COLONIAL

80 cm x 80 cm x 1,1 cm P1760113 / 100190902 G373

Butech: Colorstuk Rapid n Tabaco B21522255/100236823

### EMBALAJE / PACKING

MODELO MODEL	PZ/CJ	M2/CJ	*KG/CJ	CJ/PAL	M2/PAL	*KG/PAL	ADHESIVO ADHESIVE BUTECH
80 cm x 80 cm	2	1,28	33,32	40	51,2	1332,9	One-flex Premium / Super-flex s2

\*valores aproximados. \*approximated values.

LO  
O

El gres porcelánico STON-KER® está concebido para su utilización en suelos y paredes, tanto interiores como exteriores, gracias a sus altas prestaciones técnicas, que le permiten soportar las condiciones atmosféricas más extremas, ofreciendo al mismo tiempo una alta resistencia al desgaste.

**STON-KER®**

*STON-KER® porcelain tiles are conceived for use on indoor or outdoor walls and floors, thanks to their high-performance properties. These allow them to withstand even the most extreme weather conditions, ensuring a high resistance to wear and tear.*

**STON-KER®**



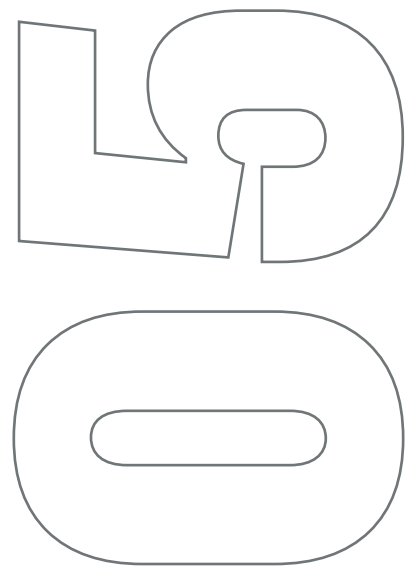

STONES

ARIZONA	201	
DECO BERNA _ BERNA	204	
BLUESTONE	209	
BOSTON	211	
CEILÁN	215	
CEPPO	217	
DURANGO	219	<b>NEW</b>
SUMATRA _ PRADA	223	
RIVER	227	
SAMOA	231	
TEIDE	233	

CONCRETES

ASTON	235	
MARBELLA _ BOTTEGA	236	
DOVER ANTIQUE _ DOVER	241	
DECO HARLEM _ HARLEM	245	
KARACHI	249	<b>NEW</b>
MÉXICO	251	
MICROCEMENTO	253	
BOMBAY _ NANTES	255	
ANTIQUE _ PARK	258	
RODANO	261	
SOHO	265	
TOSCANA	267	

MONOCOLORS

EXTREME	269	
MATT	271	
TECHNIC	273	

TEXTURES

BARCELONA	275	
SAFARI	277	





PAV. / FLOOR TILE: ARIZONA STONE 43,5 cm x 65,9 cm

# ARIZONA

Gres Porcellanato Rectificado · Color Masa / Rectified Porcellanato Tiles · Coloured Biscuit



**ARIZONA STONE**  
43,5 cm x 65,9 cm x 1,1 cm P1956630 / 100088091 G344

**ARIZONA STONE ANTISLIP**  
43,5 cm x 65,9 cm x 1,1 cm P1956652 / 10011599 G354

*Butech: Colorstuk Rapid n Cemento B21522249/100236449*



**ARIZONA ARENA**  
43,5 cm x 65,9 cm x 1,1 cm P1956629 / 100088083 G344

**ARIZONA ARENA ANTISLIP**  
43,5 cm x 65,9 cm x 1,1 cm P1956653 / 10011597 G354

*Butech: Colorstuk Rapid n Cemento B21522249/100236449  
Colorstuk Rapid n Beige B21522252/100236808*



**ARIZONA CALIZA**  
43,5 cm x 65,9 cm x 1,1 cm P1956631 / 100088088 G344

**ARIZONA CALIZA ANTISLIP**  
43,5 cm x 65,9 cm x 1,1 cm P1956675 / 100125191 G354

*Butech: Colorstuk Rapid n Cemento B21522249/100236449  
Colorstuk Rapid n Gris B21522258/100236834*





**EMBALAJE / PACKING**

MODELO MODEL	PZ/CJ	M2/CJ	*KG/CJ	CJ/PAL	M2/PAL	*KG/PAL	ADHESIVO ADHESIVE BUTECH
43,5 cm x 65,9 cm	3	0,86	21,18	60	51,6	1270,92	Fr-one n / One-flex Premium
Zócalo 9 cm x 65,9 cm	12	0,71	17,88	80	56,94	1430,79	
HT 31,6 cm x 65,9 cm	2	0,46	12,34	40	18,4	479,2	
HTE 31,6 cm x 65,9 cm	1	0,23	6,17	40	9,2	246,79	

\*valores aproximados. \*approximated values.

**HUELLA TÉCNICA / STEP TILES**

MODELO MODEL	31,6 cm x 65,9 cm		ESQUINA DE. / R. CORNER		ESQUINA IZ. / L. CORNER	
ARIZONA STONE	P8680005 / 100122038	G130	P8680053 / 100122825	G150	P8680135 / 100122873	G150
ARIZONA STONE ANT.	P8680148 / 100136663	G130	P8680170 / 100139978	G150	P8680174 / 100140102	G150
ARIZONA CALIZA	P8680001 / 100121357	G130	P8680000 / 100121359	G150	P8680142 / 100122871	G150
ARIZONA CALIZA ANT.	P8680145 / 100125188	G130	P8680173 / 100139977	G150	P8680169 / 100140101	G150
ARIZONA ARENA	P8680007 / 100122034	G130	P8680052 / 100122822	G150	P8680134 / 100122869	G150
ARIZONA ARENA ANT.	P8680166 / 100137412	G130	P8680172 / 100139976	G150	P8680168 / 100140100	G150

**ZÓCALO / SKIRTING BOARDS**

MODELO MODEL	9 cm x 59,6 cm	
ARIZONA STONE	P4060001 / 100139704	G34
ARIZONA CALIZA	P4060000 / 100139703	G34
ARIZONA ARENA	P4060003 / 100139702	G34



# BERNA

Gres Porcellanato Rectificado · Color Masa / Rectified Porcellanato Tiles · Coloured Biscuit



## BERNA ACERO

120 cm x 120 cm x 1,15 cm	P9202359 / 100245351	G392	HIGHKER	
80 cm x 80 cm x 1,11 cm	P1760182 / 100245626	G369	HIGHKER	
59,6 cm x 59,6 cm x 1,03 cm	P1857120 / 100245391	G354		

## BERNA ACERO ANTISLIP

120 cm x 120 cm x 1,15 cm	P9202365 / 100245605	G393	HIGHKER	
---------------------------	----------------------	------	---------	--

Butech: Colorstuk Rapid n Manhattan B21522248/100236464



## BERNA ACERO NAT

59,6 cm x 59,6 cm x 2 cm	C27902621 / 100275993	G1664		
--------------------------	-----------------------	-------	--	--

Butech: Colorstuk Rapid n Manhattan B21522248/100236464

USO EXCLUSIVO PARA EXTERIORES.  
PRODUCTO COMERCIALIZADO POR URBATEK.  
ONLY FOR EXTERIOR USE.  
PRODUCT MARKETED BY URBATEK.

# BERNA DECO BERN A

Gres Porcellanato Rectificado · Color Masa / Rectified Porcellanato Tiles · Coloured Biscuit



## BERNA CALIZA

120 cm x 120 cm x 1,15 cm	P9202361 / 100245357	G392	HIGHKER	
80 cm x 80 cm x 1,11 cm	P1760177 / 100245606	G369	HIGHKER	
59,6 cm x 59,6 cm x 1,03 cm	P1857124 / 100245364	G354		

## MOSA-RIVER CALIZA ANTISLIP

120 cm x 120 cm x 1,15 cm	P9202366 / 100245607	G393	HIGHKER	
---------------------------	----------------------	------	---------	--

Butech: Colorstuk Rapid n Beige B21522252/100236808



## DECO BERN A

59,6 cm x 59,6 cm x 1,03 cm	P1857122 / 10024535	G359		
-----------------------------	---------------------	------	--	--

Butech: Colorstuk Rapid n Manhattan B21522248/100236464

DECO BERN A ESTÁ FORMADA POR 6 DECORADOS DISTINTOS ALEATORIOS.  
DECO BERN A IS MADE IN 6 DIFFERENT RANDOM PATTERNS.



## BERNA TOPO

59,6 cm x 180 cm x 1,11 cm	P3570031 / 100245384	G371	HIGHKER	
120 cm x 120 cm x 1,15 cm	P9202360 / 100245394	G392	HIGHKER	
80 cm x 80 cm x 1,11 cm	P1760180 / 100245608	G369	HIGHKER	
43,5 cm x 65,9 cm x 1,11 cm	P1956705 / 100245401	G344		
59,6 cm x 59,6 cm x 1,03 cm	P1857123 / 100245373	G354		

## BERNA TOPO ANTISLIP

120 cm x 120 cm x 1,15 cm	P9202367 / 100245623	G393	HIGHKER	
43,5 cm x 65,9 cm x 1,11 cm	P1956703 / 100245348	G354		

Butech: Colorstuk Rapid n Manhattan B21522248/100236464





**EMBALAJE / PACKING**

MODELO MODEL	PZ/CJ	M2/CJ	*KG/CJ	CJ/PAL	M2/PAL	*KG/PAL	ADHESIVO ADHESIVE BUTECH
59,6 cm x 180 cm	2	2,15	56,93	24	51,50	1407,31	One-flex Premium / Super-flex s2
120 cm x 120 cm	1	1,44	38,72	33	47,52	1277,83	One-flex Premium / Super-flex s2
80 cm x 80 cm	2	1,28	32,40	40	51,20	1296,00	One-flex Premium / Super-flex s2
43,5 cm x 65,9 cm	3	0,86	21,39	60	51,60	1283,22	Fr-one n / One-flex Premium
59,6 cm x 59,6 cm	4	1,42	34,38	32	45,47	1100,03	Fr-one n / One-flex Premium
Zócalo 9 cm x 120 cm	6	0,65	8,22	40	25,92	328,8	
Zócalo 9 cm x 80 cm	12	0,86	24	42	36,29	1.008	
Zócalo 9 cm x 65,9 cm	18	0,97	22,77	56	54,07	1.275,12	
Zócalo 9 cm x 59,6 cm	12	0,71	18	80	56,94	1.440	
HT 31,6 cm x 120 cm	2	0,84	22,36	26	21,78	581,26	
HTE 31,6 cm x 120 cm	1	0,43	11,18	26	11,19	290,63	
HT 31,6 cm x 80 cm	2	0,56	14,90	26	14,52	387,50	
HTE 31,6 cm x 80 cm	1	0,29	7,45	26	7,56	193,75	
HT 31,6 cm x 65,9 cm	2	0,46	13,23	40	18,40	576	
HTE 31,6 cm x 65,9 cm	1	0,24	6,61	40	9,66	288	
HT 31,6 cm x 59,6 cm	2	0,42	12	48	19,97	529,04	
HTE 31,6 cm x 59,6 cm	1	0,22	6	48	10,54	264,52	

\*valores aproximados. \*approximated values.

**HUELLA TÉCNICA / STEP TILES**



MODELO MODEL	31,6 cm x 120 cm	ESQUINA DE. / R. CORNER	ESQUINA IZ. / L. CORNER
BERNA ACERO	P8670300 / 100246524 G180	P8670289 / 100246408 G187	P8670284 / 100246459 G187
BERNA ACERO ANT.	P8670299 / 100246553 G180	P8670292 / 100246474 G187	P8670303 / 100246503 G187
BERNA GREY	P8670295 / 100246570 G180	P8670294 / 100246449 G187	P8670302 / 100246458 G187
BERNA GREY ANT.	P8670287 / 100246462 G180	P8670293 / 100246457 G187	P8670288 / 100246465 G187
BERNA CALIZA	P8670297 / 100246554 G180	P8670290 / 100246455 G187	P8670307 / 100246481 G187
BERNA CALIZA ANT.	P8670305 / 100246482 G180	P8670291 / 100246456 G187	P8670306 / 100246513 G187
BERNA TOPO	P8670298 / 100246547 G180	P8670285 / 100246378 G187	P8670304 / 100246512 G187
BERNA TOPO ANT.	P8670296 / 100246579 G180	P8670286 / 100246409 G187	P8670301 / 100246504 G187

MODELO MODEL	31,6 cm x 80 cm	ESQUINA DE. / R. CORNER	ESQUINA IZ. / L. CORNER
BERNA ACERO	P9210805 / 100246562 G153	P9210790 / 100246379 G181	P9210817 / 100246501 G181
BERNA GREY	P9210818 / 100246505 G153	P9210814 / 100246475 G181	P9210816 / 100246500 G181
BERNA CALIZA	P9210807 / 100246526 G153	P9210788 / 100246461 G181	P9210815 / 100246491 G181
BERNA TOPO	P9210821 / 100246527 G153	P9210792 / 100246439 G181	P9210809 / 100246477 G181

MODELO MODEL	31,6 cm x 65,9 cm	ESQUINA DE. / R. CORNER	ESQUINA IZ. / L. CORNER
BERNA TOPO	P8670298 / 100246547 G130	P8670285 / 100246378 G150	P8670304 / 100246512 G150
BERNA TOPO ANT.	P8670296 / 100246579 G130	P8670286 / 100246409 G150	P8670301 / 100246504 G150

MODELO MODEL	31,6 cm x 59,6 cm	ESQUINA DE. / R. CORNER	ESQUINA IZ. / L. CORNER
BERNA ACERO	P9210819 / 100246552 G130	P9210812 / 100246493 G150	P9210811 / 100246498 G150
BERNA GREY	P9210799 / 100246572 G130	P9210794 / 100246494 G150	P9210810 / 100246486 G150
BERNA CALIZA	P9210806 / 100246546 G130	P9210813 / 100246483 G150	P9210808 / 100246533 G150
BERNA TOPO	P9210820 / 100246549 G130	P9210795 / 100246466 G150	P9210822 / 100246521 G150

**ZÓCALO / SKIRTING BOARDS**



MODELO MODEL	9 cm x 120 cm	9 cm x 80 cm	9 cm x 65,9 cm	9 cm x 59,6 cm
BERNA ACERO	P4220021 / 100246567 G78	P4160052 / 100246585 G63		P9210798 / 100246599 G30
BERNA GREY	P4220020 / 100246594 G78	P4160053 / 100246600 G63		P9210796 / 100246595 G30
BERNA CALIZA	P4220022 / 100246563 G78	P4160050 / 100246564 G63		P9210802 / 100246559 G30
BERNA TOPO	P4220019 / 100246586 G78	P4160051 / 100246596 G63	P4060046 / 100246610 G34	P9210800 / 100246539 G30







# BLUESTONE

Gres Porcellanato Rectificado · Color Masa / Rectified Porcellanato Tiles · Coloured Biscuit



## BLUESTONE ACERO

59,6 cm x 59,6 cm x 1,1 cm

P1857003 / 100179074 G354

Butech: Colorstuk Rapid n Manhattan B21522248/100236464

## EMBALAJE / PACKING

MODELO MODEL	PZ/CJ	M2/CJ	*KG/CJ	CJ/PAL	M2/PAL	*KG/PAL	ADHESIVO ADHESIVE BUTECH
59,6 cm x 59,6 cm	4	1,42	37,49	32	45,47	1127,62	Fr-one n / One-flex Premium
Zócalo 9 cm x 59,6 cm	18	0,97	123,25	56	54,07	1301,92	
HT 31,6 cm x 59,6 cm	2	0,42	11,33	48	19,97	543,84	
HTE 31,6 cm x 59,6 cm	1	0,21	5,67	48	9,98	271,92	

\*valores aproximados. \*approximated values.

## HUELLA TÉCNICA / STEP TILES

MODELO MODEL	31,6 cm x 59,6 cm	ESQUINA DE. / R. CORNER	ESQUINA IZ. / L. CORNER
BLUESTONE ACERO	P9210335 / 100180330 G130	P9210334 / 100180350 G150	P9210341 / 100180333 G150

## ZÓCALO / SKIRTING BOARDS

MODELO MODEL	9 cm x 59,6 cm
BLUESTONE ACERO	9210345 / 100180291 G30





PAV. / FLOOR TILE: BOSTON TOPO 43,5 cm x 65,9 cm \_REV. / WALL TILE: BOSTON TOPO 59,6 cm x 180 cm

# BOSTON

Gres Porcellanato Rectificado · Color Masa / Rectified Porcellanato Tiles · Coloured Biscuit



## BOSTON STONE

59,6 cm x 180 cm x 1,2 cm P3570000 / 100179318 G371  
 43,5 cm x 65,9 cm x 1,1 cm P1956689 / 100179183 G344

HIGHKER

## BOSTON STONE ANTISLIP

43,5 cm x 65,9 cm x 1,1 cm P1956693 / 100180941 G354

Butech: Colorstuk Rapid n Cemento B21522249/100236449



## BOSTON TOPO

59,6 cm x 180 cm x 1,2 cm P3570002 / 100179326 G371  
 43,5 cm x 65,9 cm x 1,1 cm P1956690 / 100179203 G344

HIGHKER

## BOSTON TOPO ANTISLIP

43,5 cm x 65,9 cm x 1,1 cm P1956694 / 100180913 G354

Butech: Colorstuk Rapid n Manhattan B21522248/100236464



## BOSTON BONE

59,6 cm x 180 cm x 1,2 cm P3570003 / 100179347 G371  
 43,5 cm x 65,9 cm x 1,1 cm P1956688 / 100179098 G344

HIGHKER

Butech: Colorstuk Rapid n Gris B21522258/100236834



## BOSTON GRAFITO

43,5 cm x 65,9 cm x 1,1 cm P1956691 / 100179191 G344

## BOSTON GRAFITO ANTISLIP

43,5 cm x 65,9 cm x 1,1 cm P1956692 / 100180940 G354

Butech: Colorstuk Rapid n Negro B21522251/100236475



STON-KER



### EMBALAJE / PACKING

MODELO MODEL	PZ/CJ	M2/CJ	*KG/CJ	CJ/PAL	M2/PAL	*KG/PAL	ADHESIVO ADHESIVE BUTECH
59,6 cm x 180 cm	2	2,15	58,64	24	51,5	1407,31	One-flex Premium / Super-flex s2
43,5 cm x 65,9 cm	3	0,86	21,15	60	54,6	1269,06	
Zócalo 9 cm x 65,9 cm	12	0,71	17,88	80	56,94	1430,79	
HT 31,6 cm x 65,9 cm	2	0,42	11,33	48	19,97	543,84	
HTE 31,6 cm x 65,9 cm	1	0,21	5,67	48	9,98	271,92	

\*valores aproximados. \*approximated values.

### HUELLA TÉCNICA / STEP TILES

MODELO MODEL	31,6 cm x 69,5 cm		ESQUINA DE. / R. CORNER		ESQUINA IZ. / L. CORNER	
BOSTON STONE	P8680245 / 100181492	G130	P8680232 / 100181466	G150	P8680239 / 100181480	G150
BOSTON STONE ANT.	P8680246 / 100181504	G130	P8680233 / 100181472	G150	P8680240 / 100181473	G150
BOSTON TOPO	P8680247 / 100181510	G130	P8680234 / 100181467	G150	P8680242 / 100181474	G150
BOSTON TOPO ANT.	P8680248 / 100181485	G130	P8680235 / 100181449	G150	P8680243 / 100181481	G150
BOSTON GRAFITO	P8680241 / 100181491	G130	P8680250 / 100181489	G150	P8680237 / 100181468	G150
BOSTON GRAFITO ANT.	P8680244 / 100181503	G130	P8680231 / 100181471	G150	P8680238 / 100181469	G150
BOSTON BONE	P8680230 / 100181470	G130	P8680249 / 100181487	G150	P8680236 / 100181439	G150

### ZÓCALO / SKIRTING BOARDS

MODELO MODEL	9 cm x 65,9 cm	
BOSTON STONE	P4060038 / 100180482	G34
BOSTON TOPO	P4060037 / 100180438	G34
BOSTON BONE	P4060039 / 100180470	G34
BOSTON GRAFITO	P4060040 / 100180480	G34

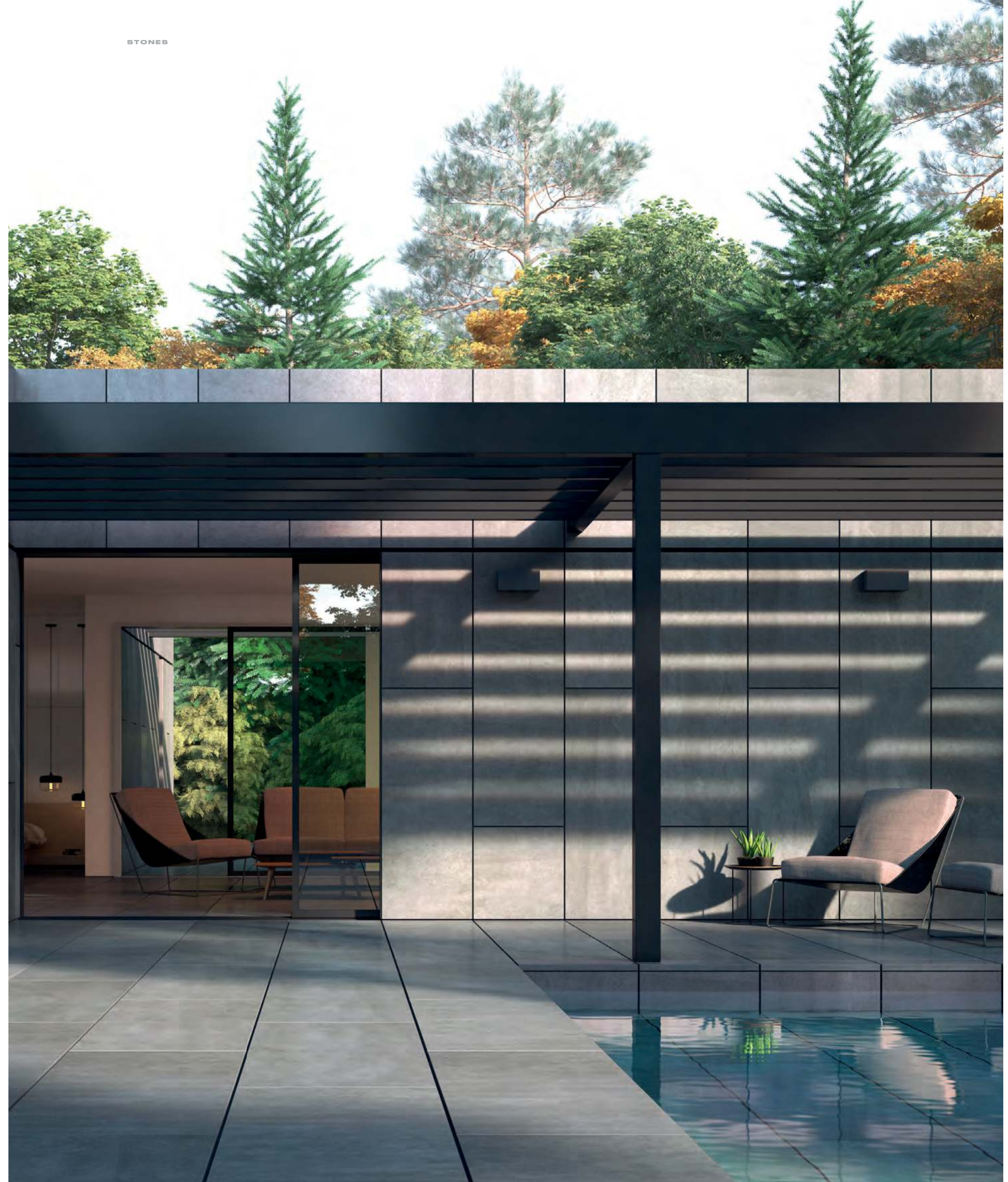





PAV. / WALL FLOOR TILE: CEILÁN MARFIL 80 cm x 80 cm

## CEILÁN

Gres Porcellanato Rectificado · Color Masa / Rectified Porcellanato Tiles · Coloured Biscuit



### CEILÁN MARFIL

80 cm x 80 cm x 1,2 cm P1760074 / 100153704 G369 HIGHKER  
59,6 cm x 59,6 cm x 1,1 cm P1856889 / 100137603 G354

Butech: Colorstuk Rapid n Beige B21522252/100236808

### EMBALAJE / PACKING

MODELO MODEL	PZ/CJ	M2/CJ	*KG/CJ	CJ/PAL	M2/PAL	*KG/PAL	ADHESIVO ADHESIVE BUTECH
80 cm x 80cm	2	1,28	35,7	40	51,2	1427,91	One-flex Premium / Super-flex s2
59,6 cm x 59,6 cm	4	1,42	35,24	32	45,47	1127,62	
Zócalo 9 cm x 80 cm	12	0,86	23,16	42	36,29	972,72	
Zócalo 9 cm x 59,6 cm	18	0,97	23,25	56	54,07	1301,92	
HT 31,6 cm x 59,6 cm	2	0,42	11,33	48	19,97	543,84	
HTE 31,6 cm x 59,6 cm	1	0,21	5,67	48	9,98	271,92	

\*valores aproximados. \*approximated values.

### HUELLA TÉCNICA / STEP TILES

MODELO MODEL	31,6 cm x 80 cm	ESQUINA DE. / R. CORNER	ESQUINA IZ. / L. CORNER
CEILÁN MARFIL	P9200581 / 100156452 G153	P9200582 / 100156453 G181	P9200583 / 100156454 G181

MODELO MODEL	31,6 cm x 59,6 cm	ESQUINA DE. / R. CORNER	ESQUINA IZ. / L. CORNER
CEILÁN MARFIL	P9210043 / 100122112 G130	P9210081 / 100122960 G150	P9210083 / 100122994 G150

### ZÓCALO / SKIRTING BOARDS

MODELO MODEL	9 cm x 80 cm	9 cm x 59,6 cm
CEILÁN MARFIL	P4160000 / 100140548 G63	P9210162 / 100138014 G30





PAV. / FLOOR TILE: CEPPPO STONE 80 cm x 80 cm

# CEPPO

Gres Porcellanato Rectificado · Color Masa / Rectified Porcellanato Tiles · Coloured Biscuit



**CEPPO ACERO**  
80 cm x 80 cm x 1,1 cm P1760155 / 100226457 G369 HIGHKER  
Butech: Colorstuk Rapid n Cemento B21522249/100236449

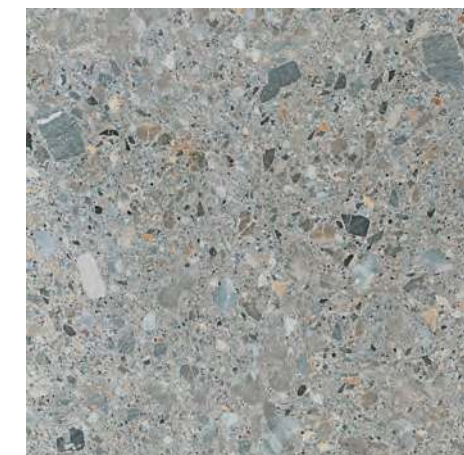

**CEPPO STONE**  
80 cm x 80 cm x 1,1 cm P1760154 / 100226448 G369 HIGHKER  
Butech: Colorstuk Rapid n Cemento B21522249/100236449

## EMBALAJE / PACKING

MODELO MODEL	PZ/CJ	M2/CJ	*KG/CJ	CJ/PAL	M2/PAL	*KG/PAL	ADHESIVO ADHESIVE BUTECH
80 cm x 80 cm	2	1,28	32,83	40	51,20	1313,04	One-flex Premium / Super-flex s2
Zócalo 9 cm x 59,6 cm	12	0,86	24	42	36,29	1008	
HT 31,6 cm x 59,6 cm	2	0,56	14,9	26	14,52	387,5	
HTE 31,6 cm x 59,6 cm	1	0,29	7,45	26	7,56	193,75	

\*valores aproximados. \*approximated values.

## HUELLA TÉCNICA / STEP TILES

MODELO MODEL	31,6 cm x 80 cm		ESQUINA DE. / R. CORNER		ESQUINA IZ. / L. CORNER	
CEPPO STONE	P9210649 / 100227256	G153	P9210653 / 100227291	G181	P9210656 / 100227287	G181
CEPPO ACERO	P9210640 / 10022727	G153	P9210648 / 100227276	G181	P9210645 / 100227292	G181

## ZÓCALO / SKIRTING BOARDS

MODELO MODEL	9 cm x 80 cm	
CEPPO STONE	P4160044 / 100227247	G63
CEPPO ACERO	P4160046 / 100227234	G63





PAV. / FLOOR TILE: DURANGO TOPO 100 cm x 100 cm x 100 cm

# DURANGO

Gres Porcellanato Rectificado · Color Masa / Rectified Porcellanato Tiles · Coloured Biscuit



**NEW**



**DURANGO ACERO**  
 100 cm x 100 cm x 1,2 cm P3590020 / 100272165 G377 HIGHKER  
 59,6 cm x 59,6 cm x 1 cm P1857141 / 100272136 G354  
**DURANGO ACERO ANTISLIP**  
 100 cm x 100 cm x 1,2 cm P3590026 / 100278315 G382  
 59,6 cm x 59,6 cm x 1 cm P1857146 / 100278431 G359  
*Butech: Colorstuk Rapid n Gris B21522258/100236834*



**DURANGO BONE**  
 100 cm x 100 cm x 1,2 cm P3590021 / 100272157 G377 HIGHKER  
 59,6 cm x 59,6 cm x 1 cm P1857140 / 100272167 G354  
**DURANGO BONE ANTISLIP**  
 100 cm x 100 cm x 1,2 cm P3590027 / 100278316 G382  
 59,6 cm x 59,6 cm x 1 cm P1857148 / 100278433 G359  
*Butech: Colorstuk Rapid n Gris B21522258/100236834*



**DURANGO SILVER**  
 100 cm x 100 cm x 1,2 cm P3590023 / 100272212 G377 HIGHKER  
 59,6 cm x 59,6 cm x 1 cm P1857143 / 100272197 G354  
**DURANGO SILVER ANTISLIP**  
 100 cm x 100 cm x 1,2 cm P3590029 / 100278296 G382  
 59,6 cm x 59,6 cm x 1 cm P1857147 / 100278422 G359  
*Butech: Colorstuk Rapid n Cemento B21522249/100236449*



**DURANGO TOPO**  
 100 cm x 100 cm x 1,2 cm P3590024 / 100273245 G377 HIGHKER  
 59,6 cm x 59,6 cm x 1 cm P1857144 / 100273216 G354  
**DURANGO TOPO ANTISLIP**  
 100 cm x 100 cm x 1,2 cm P3590028 / 100278322 G382  
 59,6 cm x 59,6 cm x 1 cm P1857149 / 100278434 G359  
*Butech: Colorstuk Rapid n Cemento B21522249/100236449*



STON-KER



**EMBALAJE / PACKING**

MODELO MODEL	PZ/CJ	M2/CJ	*KG/CJ	CJ/PAL	M2/PAL	*KG/PAL	ADHESIVO ADHESIVE BUTECH
100 cm x 100cm	1	1,28	27,63	33	33	911,88	One-flex Premium / Super-flex s2
59,6 cm x 59,6 cm	4	1,42	34,06	32	45,46	1089,92	Fr-one n / One-flex Premium
Zócalo 9 cm x 100 cm	6	0,54	6,84	40	21,60	273,84	
Zócalo 9 cm x 59,6 cm	18	0,96	22,77	56	54,06	1275,12	
HT 31,6 cm x 100 cm	2	0,69	18,63	26	18,14	484,38	
HTE 31,6 cm x 100 cm	1	0,36	9,31	26	9,37	242,19	
HT 31,6 cm x 59,6 cm	2	0,41	12	48	19,96	576	
HTE 31,6 cm x 59,6 cm	1	0,22	6	26	10,53	288	

\*valores aproximados. \*approximated values.

**HUELLA TÉCNICA / STEP TILES**

MODELO MODEL	31,6 cm x 100 cm		ESQUINA DE. / R. CORNER		ESQUINA IZ. / L. CORNER	
DURANGO ACERO	P9210866 / 100274468	G164	P9210871 / 100274500	G183	P9210862 / 100274498	G183
DURANGO BONE	P9210863 / 100274494	G164	P9210869 / 100274530	G183	P9210870 / 100274476	G183
DURANGO SILVER	P9210865 / 100274495	G164	P9210867 / 100274503	G183	P9210872 / 100274502	G183
DURANGO TOPO	P9210864 / 100274496	G164	P9210861 / 100274532	G183	P9210868 / 100274521	G183

MODELO MODEL	31,6 cm x 59,6 cm		ESQUINA DE. / R. CORNER		ESQUINA IZ. / L. CORNER	
DURANGO ACERO	P9210879 / 100274501	G130	P9210873 / P92108731	G150	P9210876 / P92108761	G150
DURANGO BONE	P9210882 / 100274486	G130	P9210884 / 100274524	G150	P9210878 / 100274477	G150
DURANGO SILVER	P9210880 / 100274469	G130	P9210877 / 100274479	G150	P9210875 / 100274512	G150
DURANGO TOPO	P9210874 / 100274488	G130	P9210883 / 100274514	G150	P9210881 / 100274522	G150

**ZÓCALO / SKIRTING BOARDS**

MODELO MODEL	9 cm x 100 cm		9 cm x 59,6 cm	
DURANGO ACERO	P9203329 / 100274481	G74	P9210858 / 100274459	G30
DURANGO BONE	P9203324 / 100274445	G74	P9210854 / 100274465	G30
DURANGO SILVER	P9203326 / 100274456	G74	P9210852 / 100274457	G30
DURANGO TOPO	P9203327 / 100274474	G74	P9210856 / 100274443	G30







PAV. / FLOOR TILE: PRADA ACERO 120 cm x 120 cm \_REV. / WALL TILE: MATT 45 cm x 120 cm , STRIPE MATT 45 cm x 120 cm

## PRADA SUMATRA

Gres Porcellanato Rectificado · Color Masa / Rectified Porcellanato Tiles · Coloured Biscuit



### PRADA ACERO

120 cm x 120 cm x 1,15 cm P9202153 / 100239993 G392 HIGHKER   
59,6 cm x 59,6 cm x 1,03 cm P1857100 / 100239890 G354

### PRADA ACERO ANTISLIP

59,6 cm x 59,6 cm x 1,03 cm P1857113 / 100243287 G359

Butech: Colorstuk Rapid n Gris B21522258/100236834



### PRADA WHITE

59,6 cm x 59,6 cm x 1,03 cm  
P1857119 / 100245380 G354

Butech: Colorstuk Rapid n Gris B21522258/100236834



### PRADA CALIZA

59,6 cm x 59,6 cm x 1,03 cm  
P1857095 / 100239849 G354

### PRADA CALIZA ANTISLIP

59,6 cm x 59,6 cm x 1,03 cm

P1857114 / 100243304 G359

Butech: Colorstuk Rapid n Marfil B21522257/100236794



### SUMATRA

59,6 cm x 59,6 cm x 1,03 cm  
P1857103 / 100239900 G359

Butech: Colorstuk Rapid n Cemento B21522249/100236449

SUMATRA ESTÁ FORMADA POR 12 DECORADOS DISTINTOS ALEATORIOS.  
SUMATRA IS MADE IN 12 DIFFERENT RANDOM PATTERNS.



### EMBALAJE / PACKING

MODELO MODEL	PZ/CJ	M2/CJ	*KG/CJ	CJ/PAL	M2/PAL	*KG/PAL	ADHESIVO ADHESIVE BUTECH
120 cm x 120 cm	1	1,44	38,72	33	47,52	1277,83	One-flex Premium / Súper-flex s2
59,6 cm x 59,6 cm	4	1,42	23,16	32	45,47	972,72	Fr-one n / One-flex Premium
Zócalo 9 cm x 120 cm	6	0,65	8,22	40	25,92	264,24	
Zócalo 9 cm x 59,6 cm	18	0,86	23,16	42	36,29	972,72	
HT 31,6 cm x 120 cm	2	0,84	22,36	26	21,78	581,26	
HTE 31,6 cm x 120 cm	1	0,43	11,18	26	11,19	290,63	
HT 31,6 cm x 59,6 cm	2	0,42	12	48	19,97	576	
HTE 31,6 cm x 59,6 cm	1	0,22	6	48	10,54	288	

\*valores aproximados. \*approximated values.

### HUELLA TÉCNICA / STEP TILES

MODELO MODEL	31,6 cm x 120 cm		ESQUINA DE. / R. CORNER		ESQUINA IZ. / L. CORNER	
PRADA ACERO	P8670266 / 100242281	G180	P8670259 / 100242260	G187	P8670270 / 100242208	G187

MODELO MODEL	31,6 cm x 59,6 cm		ESQUINA DE. / R. CORNER		ESQUINA IZ. / L. CORNER	
PRADA ACERO	P9210728 / 100242313	G130	P9210707 / 100242268	G150	P9210703 / 100242284	G150
PRADA ACERO ANT.	P9210779 / 100246590	G130	P9210763 / 100246485	G150	P9210782 / 100246623	G150
PRADA CALIZA	P9210709 / 100242287	G130	P9210716 / 100242307	G150	P9210711 / 100242293	G150
PRADA CALIZA ANT.	P9210776 / 100246556	G130	P9210765 / 100246469	G150	P9210777 / 100246583	G150
PRADA WHITE	P9210780 / 100246592	G130	P9210766 / 100246540	G150	P9210767 / 100246561	G150

### ZÓCALO / SKIRTING BOARDS

MODELO MODEL	9 cm x 120 cm		9 cm x 59,6 cm	
PRADA ACERO	P4220009 / 100242347	G78	P9210735 / 100242375	G30
PRADA CALIZA			P9210737 / 100242356	G30
PRADA WHITE			P9210781 / 100246620	G30









**EMBALAJE / PACKING**

MODELO MODEL	PZ/CJ	M2/CJ	*KG/CJ	CJ/PAL	M2/PAL	*KG/PAL	ADHESIVO ADHESIVE BUTECH
59,5 cm x 120 cm	2	1,43	38,54	28	40,05	1079,01	One-flex Premium / Super-flex s2
Zócalo 9 cm x 120 cm	12	1,3	16,44	48	62,62	789,12	
HT 31,6 cm x 120 cm	2	0,84	22,36	26	21,78	581,26	
HTE 31,6 cm x 120 cm	1	0,43	11,18	26	11,19	290,63	

\*valores aproximados. \*approximated values.

**HUELLA TÉCNICA / STEP TILES**



MODELO MODEL	31,6 cm x 120 cm		ESQUINA DE. / R. CORNER		ESQUINA IZ. / L. CORNER	
RIVER ANTRACITA	P8670215 / 100227440	G180	P8670208 / 100227359	G187	P8670204 / 100227443	G187
R. ANTRACITA ANT.	P8670205 / 100227432	G180	P8670221 / 100227369	G187	P8670211 / 100227444	G187
RIVER STONE	P8670207 / 100227434	G180	P8670212 / 100227379	G187	P8670219 / 100227424	G187
R.STONE ANT.	P8670220 / 100227435	G180	P8670214 / 100227413	G187	P8670216 / 100227425	G187
RIVER SILVER	P8670206 / 100227433	G180	P8670210 / 100227396	G187	P8670218 / 100227445	G187
R. SILVER ANT.	P8670217 / 100227422	G180	P8670213 / 100227420	G187	P8670209 / 100227414	G187

**ZÓCALO / SKIRTING BOARDS**



MODELO MODEL	9 cm x 120 cm	
RIVER ANTRACITA	P4220006 / 100227266	G78
RIVER SILVER	P4220007 / 100227267	G78
RIVER STONE	P4220004 / 100227272	G78



PAV. / FLOOR TILE: RIVER ANTRACITA 60x60 cm x 120 cm \_REV. / WALL TILE: RIVER ANTRACITA 59,6 cm x 120 cm









PAV. / FLOOR TILE: TEIDE STONE 45 cm x 90 cm

## TEIDE

Gres Porcellanato Rectificado · Color Masa / Rectified Porcellanato Tiles · Coloured Biscuit



### TEIDE STONE

45 cm x 90 cm x 1,2 cm P1740085 / 100226586 G363

### TEIDE STONE ANTISLIP

45 cm x 90 cm x 1,2 cm P1740086 / 100226587 G366

Butech: Colorstuk Rapid n Cemento B21522249/100236449



### EMBALAJE / PACKING

MODELO MODEL	PZ/CJ	M2/CJ	*KG/CJ	CJ/PAL	M2/PAL	*KG/PAL	ADHESIVO ADHESIVE BUTECH
45 cm x 90 cm	3	1,22	30,25	44	53,46	1330,96	One-flex Premium / Super-flex s2
Zócalo 9 cm x 65,9 cm	9	0,73	18,98	36	26,24	683,32	
HT 31,6 cm x 65,9 cm	2	0,63	17,73	26	16,33	460,98	
HTE 31,6 cm x 65,9 cm	1	0,33	8,87	26	8,47	230,49	

\*valores aproximados. \*approximated values.

### HUELLA TÉCNICA / STEP TILES

MODELO MODEL	31,6 cm x 65,9 cm		ESQUINA DE. / R. CORNER		ESQUINA IZ. / L. CORNER	
TEIDE STONE	P8660243 / 100227315	G146	P8660231 / 100227332	G172	P8660224 / 100227313	G172
TEIDE STONE ANT.	P8660227 / 100227316	G146	P8660236 / 100227295	G172	P8660212 / 100227324	G172

### ZÓCALO / SKIRTING BOARDS

MODELO MODEL	9 cm x 65,9 cm	
TEIDE STONE	P9201783 / 100227246	G63





PAV. / FLOOR TILE: ASTON ACERO 59,6 cm x 59,6 cm

## ASTON

Gres Porcellanato Rectificado · Color Masa / Rectified Porcellanato Tiles · Coloured Biscuit



### ASTON ACERO

59,6 cm x 59,6 cm x 1,1 cm

P1856868 / 100137568 G354

Butech: Colorstuk Rapid n Manhattan B21522248/100236464

### EMBALAJE / PACKING

MODELO MODEL	PZ/CJ	M2/CJ	*KG/CJ	CJ/PAL	M2/PAL	*KG/PAL	ADHESIVO ADHESIVE BUTECH
59,6 cm x 59,6 cm	4	1,42	37,24	32	45,47	1127,62	Fr-one n / One-flex Premium
Zócalo 9 cm x 59,6 cm	18	0,97	23,25	56	54,07	1301,92	
HT 31,6 cm x 59,6 cm	2	0,42	11,33	48	19,97	543,84	
HTE 31,6 cm x 59,6 cm	1	0,21	5,67	48	9,98	271,92	

\*valores aproximados. \*approximated values.

### HUELLA TÉCNICA / STEP TILES

MODELO MODEL	31,6 cm x 59,6 cm	ESQUINA DE. / R. CORNER	ESQUINA IZ. / L. CORNER
ASTON ACERO	P9210058 / 100122095 G130	P9210125 / 100122955 G150	P9210127 / 100122989 G150

### ZÓCALO / SKIRTING BOARDS

MODELO MODEL	9 cm x 59,6 cm
ASTON ACERO	P9210153 / 100137998 G30

## BOTTEGA

Gres Porcellanato Rectificado · Color Masa / Rectified Porcellanato Tiles · Coloured Biscuit



### BOTTEGA ACERO

59,6 cm x 180 cm x 1,15 cm	P3570032 / 100245332	G371	HIGHKER	
120 cm x 120 cm x 1,15 cm	P9201778 / 100227107	G392	HIGHKER	
80 cm x 80 cm x 1,11 cm	P1760136 / 100214633	G369	HIGHKER	
59,6 cm x 59,6 cm x 1,03 cm	P1857072 / 100214641	G354		

### BOTTEGA ACERO ANTISLIP

120 cm x 120 cm x 1,15 cm	P9202002 / 100236505	G393	HIGHKER	
80 cm x 80 cm x 1,1 cm	P1760145 / 100221486	G373	HIGHKER	
59,6 cm x 59,6 cm x 1,03 cm	P1857076 / 100221464	G359		
59,6 cm x 59,6 cm x 1,03 cm C-2	P1857108 / 100242387	G354		

Butech: Colorstuk Rapid n Cemento B21522249/100236449



### BOTTEGA ACERO NAT

59,6 cm x 59,6 cm x 2 cm				
C27902610 / 100275992	G1664			

Butech: Colorstuk Rapid n Manhattan B21522248/100236464

USO EXCLUSIVO PARA EXTERIORES.  
PRODUCTO COMERCIALIZADO POR URBATEK.  
ONLY FOR EXTERIOR USE.  
PRODUCT MARKETED BY URBATEK.

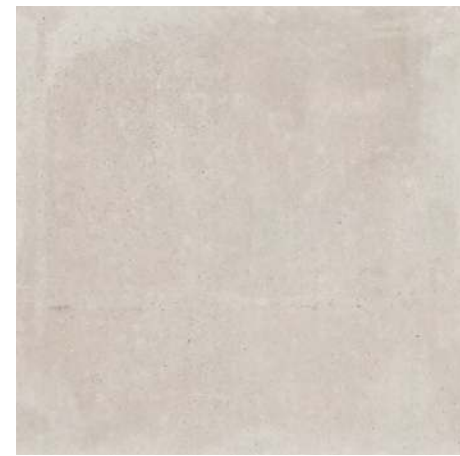

### BOTTEGA CALIZA

59,6 cm x 180 cm x 1,15 cm	P3570033 / 100245307	G371	HIGHKER	
120 cm x 120 cm x 1,15 cm	P9201603 / 100214898	G392	HIGHKER	
80 cm x 80 cm x 1,11 cm	P1760139 / 100214608	G369	HIGHKER	
59,6 cm x 59,6 cm x 1,03 cm	P1857071 / 100214648	G354		

### BOTTEGA CALIZA ANTISLIP

120 cm x 120 cm x 1,15 cm	P9201929 / 100233956	G393	HIGHKER	
80 cm x 80 cm x 1,1 cm	P1760146 / 100221502	G373	HIGHKER	
59,6 cm x 59,6 cm x 1,03 cm	P1857075 / 100221473	G359		
59,6 cm x 59,6 cm x 1,03 cm C-2	P1857109 / 100242388	G354		

Butech: Colorstuk Rapid n Marfil B21522257/100236794



### BOTTEGA CALIZA NAT

59,6 cm x 59,6 cm x 2 cm				
C27902612 / 100275996	G1664			

Butech: Colorstuk Rapid n Marfil B21522257/100236794

USO EXCLUSIVO PARA EXTERIORES.  
PRODUCTO COMERCIALIZADO POR URBATEK.  
ONLY FOR EXTERIOR USE.  
PRODUCT MARKETED BY URBATEK.

## BOTTEGA MARBELLA

Gres Porcellanato Rectificado · Color Masa / Rectified Porcellanato Tiles · Coloured Biscuit



### BOTTEGA TOPO

120 cm x 120 cm x 1,15 cm	P9201779 / 100227119	G392	HIGHKER	
80 cm x 80 cm x 1,11 cm	P1760137 / 100214622	G369	HIGHKER	
59,6 cm x 59,6 cm x 1,03 cm	P1857073 / 100214662	G354		

### BOTTEGA TOPO ANTISLIP

120 cm x 120 cm x 1,15 cm	P9202003 / 100236493	G393	HIGHKER	
80 cm x 80 cm x 1,1 cm	P1760144 / 100221465	G373	HIGHKER	
59,6 cm x 59,6 cm x 1,03 cm	P1857078 / 100221449	G359		

Butech: Colorstuk Rapid n Cemento B21522249/100236449



### BOTTEGA WHITE

120 cm x 120 cm x 1,15 cm	P92021491 / 100239911	G392	HIGHKER	
80 cm x 80 cm x 1,11 cm	P17601711 / 100239885	G369	HIGHKER	
59,6 cm x 59,6 cm x 1,03 cm	P18570971 / 100239864	G354		

Butech: Colorstuk Especial n Nacaré B24302057/100238235



### BOTTEGA ANTRACITA

120 cm x 120 cm x 1,15 cm	P9202156 / 100239883	G392	HIGHKER	
80 cm x 80 cm x 1,11 cm	P1760170 / 100240006	G369	HIGHKER	
59,6 cm x 59,6 cm x 1,03 cm	P1857102 / 100240051	G354		

### BOTTEGA ANTRACITA ANTISLIP

120 cm x 120 cm x 1,15 cm	P9202200 / 100239910	G393	HIGHKER	
80 cm x 80 cm x 1,11 cm	P1760143 / 100221481	G373	HIGHKER	
59,6 cm x 59,6 cm x 1,03 cm	P1857077 / 100221433	G359		

Butech: Colorstuk Rapid n Antracita B21522250/100236481



### MARBELLA STONE

59,6 cm x 59,6 cm x 1,03 cm				
P18570701 / 100214549	G359			

Butech: Colorstuk Rapid n Manhattan B21522248/100236464

MARBELLA STONE ESTÁ FORMADA POR 3 DECORADOS DISTINTOS ALEATORIOS.  
MARBELLA STONE IS MADE IN 3 DIFFERENT RANDOM PATTERNS.



**EMBALAJE / PACKING**

MODELO MODEL	PZ/CJ	M2/CJ	*KG/CJ	CJ/PAL	M2/PAL	*KG/PAL	ADHESIVO ADHESIVE BUTECH
59,6 cm x 180 cm	2	2,15	58,99	24	51,50	1.415,86	One-flex Premium / Super-flex s2
120 cm x 120 cm	1	1,44	38,72	33	47,52	1277,83	One-flex Premium / Super-flex s2
80 cm x 80 cm	2	1,28	32,40	40	51,20	1296,00	One-flex Premium / Super-flex s2
59,6 cm x 59,6 cm	4	1,42	34,38	32	45,47	1100,03	Fr-one n / One-flex Premium
Zócalo 9 cm x 120 cm	6	0,65	8,22	40	25,92	328,80	
Zócalo 9 cm x 80 cm	12	0,86	24	42	36,29	1008	
Zócalo 9 cm x 59,6 cm	18	0,97	22,77	56	54,07	1275,12	
HT 31,6 cm x 120 cm	2	0,84	22,36	26	21,78	581,26	
HTE 31,6 cm x 120 cm	1	0,43	11,18	26	11,19	290,63	
HT 31,6 cm x 80 cm	2	0,56	14,90	26	14,52	387,50	
HTE 31,6 cm x 80 cm	1	0,29	7,45	26	7,56	193,75	
HT 31,6 cm x 59,6 cm	2	0,42	12	48	19,97	576	
HTE 31,6 cm x 59,6 cm	1	0,42	6	48	10,54	288	

\*valores aproximados. \*approximated values.

**HUELLA TÉCNICA / STEP TILES**



MODELO MODEL	31,6 cm x 120 cm		ESQUINA DE. / R. CORNER		ESQUINA IZ. / L. CORNER	
BOTTEGA ACERO	P8670224 / 100230225	G180	P8670225 / 100232103	G187	P8670226 / 100232089	G187
B. ACERO ANT.	P8670240 / 100238179	G180	P8670277 / 100243140	G187	P8670280 / 100243106	G187
BOTTEGA CALIZA	P8670223 / 100229926	G180	P86702341 / 100234079	G187	P8670222 / 100229927	G187
B. CALIZA ANT.	P8670228 / 100233985	G180	P8670281 / 100243109	G187	P8670279 / 100243108	G187
BOTTEGA TOPO	P8670229 / 100234062	G180	P8670230 / 100234086	G187	P8670233 / 100234091	G187
B. TOPO ANT.	P8670278 / 100243107	G180	P8670276 / 100243098	G187	P8670282 / 100243086	G187
BOTTEGA WHITE	P8670253 / 100242258	G180	P8670269 / 100242242	G187	P8670265 / 100242262	G187
BOTTEGA ANTRACITA	P8670263 / 100242251	G180	P8670255 / 100242264	G187	P8670260 / 100242245	G187
B. ANTRACITA ANT.	P8670248 / 100242290	G180	P8670256 / 100242283	G187	P8670251 / 100242255	G187

MODELO MODEL	31,6 cm x 80 cm		ESQUINA DE. / R. CORNER		ESQUINA IZ. / L. CORNER	
BOTTEGA ACERO	P9210535 / 100217910	G153	P9210532 / 100217924	G181	P9210536 / 100217927	G181
B. ACERO ANT.	P9210557 / 100221965	G153	P9210551 / 100221942	G181	P9210558 / 100221968	G181
BOTTEGA CALIZA	P9210564 / 100221998	G153	P9210552 / 100221938	G181	P9210559 / 100221990	G181
B. CALIZA ANT.	P9210565 / 100222043	G153	P9210553 / 100221774	G181	P9210561 / 100222000	G181
BOTTEGA TOPO	P9210534 / 100217871	G153	P9210533 / 100217874	G181	P9210531 / 100217920	G181
B. TOPO ANT.	P9210550 / 100221922	G153	P9210555 / 100221971	G181	P9210563 / 100222014	G181
BOTTEGA WHITE	P9210697 / 100242263	G153	P9210702 / 100242228	G181	P9210700 / 100242243	G181
BOTTEGA ANTRACITA	P9210698 / 100242282	G153	P9210699 / 100242259	G181	P9210701 / 100242254	G181
B. ANTRACITA ANT.	P9210730 / 100242442	G153	P9210743 / 100242422	G181	P9210740 / 100242424	G181

MODELO MODEL	31,6 cm x 59,6 cm		ESQUINA DE. / R. CORNER		ESQUINA IZ. / L. CORNER	
BOTTEGA ACERO	P9210577 / 100221729	G130	P9210597 / 100221924	G150	P9210581 / 100221966	G150
B. ACERO ANT.	P9210589 / 100221916	G130	P9210588 / 100221925	G150	P9210575 / 100221967	G150
B. ACERO C-2	P9210745 / 100243084	G130	P9210749 / 100243123	G150	P9210747 / 100243085	G150
BOTTEGA CALIZA	P9210582 / 100221992	G130	P9210579 / 100221772	G150	P9210580 / 100221948	G150
B. CALIZA ANT.	P9210595 / 100222028	G130	P9210613 / 100221944	G150	P9210590 / 100221949	G150
B. CALIZA C-2	P9210746 / 100243113	G130	P9210750 / 100243150	G150	P9210748 / 100243114	G150
BOTTEGA TOPO	P9210592 / 100221912	G130	P9210586 / 100221778	G150	P9210605 / 100222021	G150
B. TOPO ANT.	P9210578 / 100221913	G130	P9210612 / 100221970	G150	P9210624 / 100222011	G150
BOTTEGA WHITE	P9210708 / 100242291	G130	P9210714 / 100242249	G150	P9210717 / 100242274	G150
BOTTEGA ANTRACITA	P9210720 / 100242303	G130	P9210706 / 100242248	G150	P9210710 / 100242269	G150
B. ANTRACITA ANT.	P9210732 / 100242441	G130	P9210731 / 100242432	G150	P9210736 / 100242423	G150

**ZÓCALO / SKIRTING BOARDS**



MODELO MODEL	9 cm x 120 cm		9 cm x 80 cm		9 cm x 59,6 cm	
BOTTEGA ACERO	P4220001 / 100221476	G78	P4160036 / 100217892	G63	P9210538 / 100221483	G30
BOTTEGA CALIZA	P4220002 / 100221494	G78	P4160038 / 100221485	G63	P9210543 / 100221484	G30
BOTTEGA TOPO	P4220000 / 100221495	G78	P4160037 / 100217922	G63	P9210539 / 100221437	G30
BOTTEGA WHITE	P4220012 / 100242383	G78	P4160047 / 100242345	G63	P9210744 / 100242372	G30
BOTTEGA ANTRACITA	P4220011 / 100242364	G78	P4160048 / 100242326	G63	P9210742 / 100242382	G30

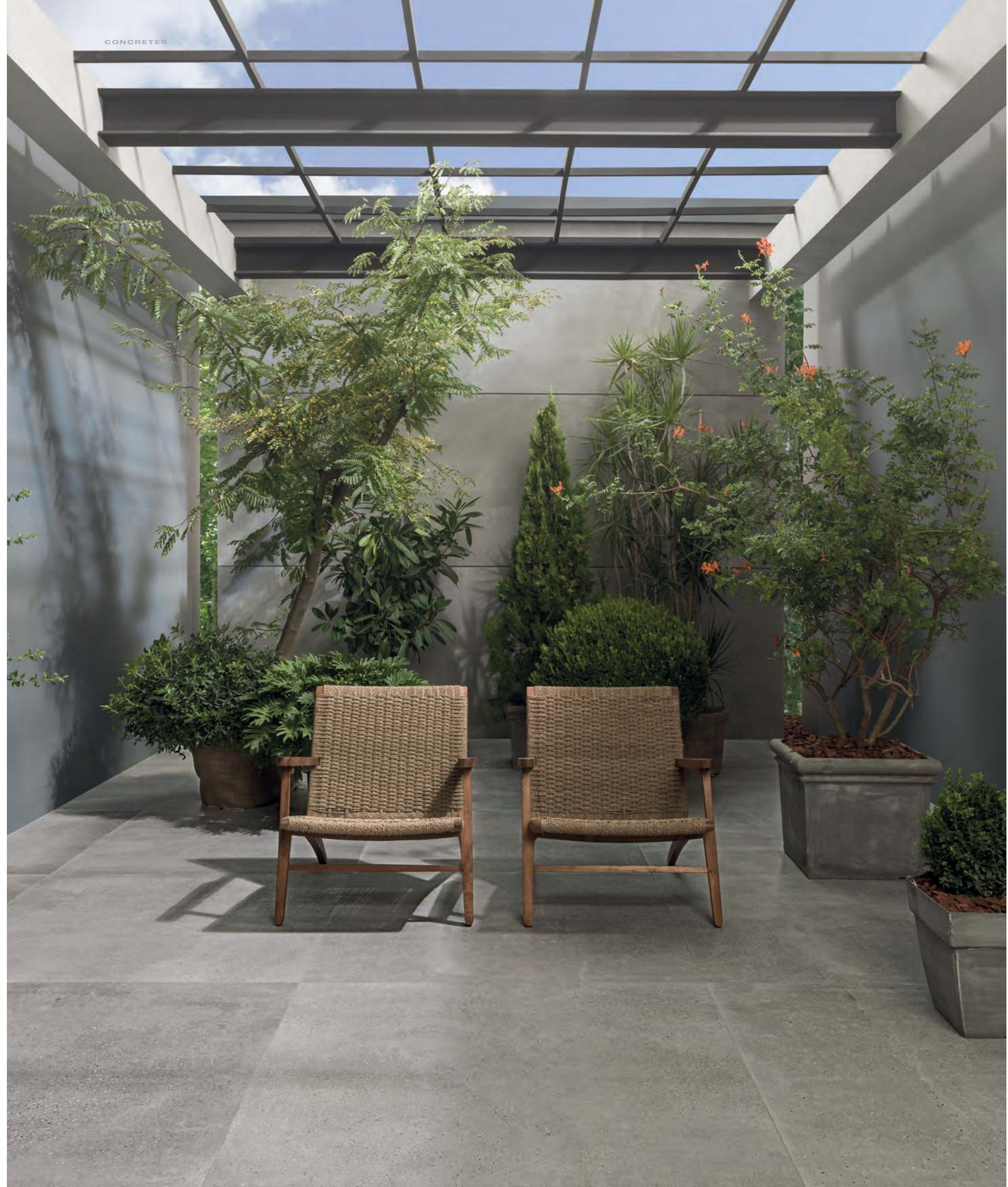





# DOVER DOVER ANTIQUE

Gres Porcellanato Rectificado · Color Masa / Rectified Porcellanato Tiles · Coloured Biscuit



**DOVER ACERO**  
 80 cm x 80 cm x 1,1 cm P1760081 / 100155569 G369 HIGHKER  
 59,6 cm x 59,6 cm x 1,1 cm P1856952 / 100155568 G354  
**DOVER ACERO ANTISLIP**  
 59,6 cm x 59,6 cm x 1,1 cm P1856966 / 100156775 G359  
 Butech: Colorstuk Rapid n Gris B21522258/100236834



**DOVER CALIZA**  
 80 cm x 80 cm x 1,1 cm P1760084 / 10015562 G369 HIGHKER  
 59,6 cm x 59,6 cm x 1,1 cm P1856955 / 100155620 G354  
**DOVER CALIZA ANTISLIP**  
 59,6 cm x 59,6 cm x 1,1 cm P1857024 / 100189014 G359  
 Butech: Colorstuk Rapid n Gris B21522258/100236834



Para la confección del acabado antislip y con el objetivo de mejorar las propiedades higiénicas, se han eliminado las imágenes más claras de la serie original.  
 For the preparation of the antislip finish and to improve the hygienic properties, the clearest images of the original range have been removed.



**DOVER ARENA**  
 59,6 cm x 59,6 cm x 1,1 cm  
 P1856954 / 100155614 G354  
**DOVER ARENA ANTISLIP**  
 59,6 cm x 59,6 cm x 1,1 cm  
 P1856967 / 100156776 G359  
 Butech: Colorstuk Rapid n Gris B21522258/100236834



**DOVER ANTIQUE**  
 59,6 cm x 59,6 cm x 1,1 cm  
 P1856953 / 100155611 G359  
 Butech: Colorstuk Rapid n Cemento B21522249/100236449

DOVER ANTIQUE ESTÁ FORMADO POR 8 DECORADOS DISTINTOS ALEATORIOS.  
 DOVER ANTIQUE RANGE IS MADE IN 8 DIFFERENT RANDOM PATTERNS.



**EMBALAJE / PACKING**

MODELO MODEL	PZ/CJ	M2/CJ	*KG/CJ	CJ/PAL	M2/PAL	*KG/PAL	ADHESIVO ADHESIVE BUTECH
80 cm x 80 cm	2	1,28	33,9	40	51,2	1355,48	One-flex Premium / Super-flex s2
59,6 cm x 59,6 cm	4	1,42	37,24	32	45,47	1127,62	Fr-one n / One-flex Premium
Zócalo 9 cm x 80 cm	12	0,86	23,16	42	36,29	972,72	
Zócalo 9 cm x 59,6 cm	18	0,97	23,25	56	54,07	1301,92	
HT 31,6 cm x 59,6 cm	2	0,42	11,33	48	19,97	543,84	
HTE 31,6 cm x 59,6 cm	1	0,21	5,67	48	9,98	271,92	

\*valores aproximados. \*approximated values.

**HUELLA TÉCNICA / STEP TILES**

MODELO MODEL	31,6 cm x 59,6 cm		ESQUINA DE. / R. CORNER		ESQUINA IZ. / L. CORNER	
DOVER ACERO	P9210263 / 100156674	G130	P9210255 / 100156670	G150	P9210264 / 100156678	G150
DOVER ACERO ANT.	P9210268 / 100156798	G130	P9210273 / 100156795	G150	P9210276 / 100156821	G150
DOVER CALIZA	P9210259 / 100156676	G130	P9210258 / 100156672	G150	P9210266 / 100156637	G150
DOVER CALIZA ANT.	P9210401 / 100193410	G130	P9210400 / 100193400	G150	P9210402 / 100193420	G150
DOVER ARENA	P9210261 / 100156675	G130	P9210257 / 100156671	G150	P9210260 / 100156679	G150
DOVER ARENA ANT.	P9210270 / 100156799	G130	P9210271 / 100156796	G150	P9210274 / 100156822	G150
	31,6 cm x 80 cm	G153		G181		G181

**ZÓCALO / SKIRTING BOARDS**

MODELO MODEL	9 cm x 80 cm		9 cm x 59,6 cm	
DOVER ACERO	P4160015 / 100156555	G63	P9210251 / 100156554	G30
DOVER CALIZA	P4160019 / 100156559	G63	P9210253 / 100156558	G30
DOVER ARENA			P9210250 / 100156556	G30







CONCRETE

PAV. / FLOOR TILE: HARLEM ACERO 120 cm x 120 cm, \_REV. / WALL TILE: HARLEM ACERO 120 cm x 120 cm

# HARLEM DECO HARLEM

Gres Porcellanato Rectificado · Color Masa / Rectified Porcellanato Tiles · Coloured Biscuit



## HARLEM ACERO

120 cm x 120 cm x 1,15 cm	P9201793 / 100229348	G392	HIGHKER	
80 cm x 80 cm x 1,2 cm	P1760062 / 100145836	G369	HIGHKER	
59,6 cm x 59,6 cm x 1,1 cm	P1856923 / 100145386	G354		

## HARLEM ACERO ANTISLIP

120 cm x 120 cm x 1,15 cm	P9202001 / 10023653	G393	HIGHKER	
---------------------------	---------------------	------	---------	--

Butech: Colorstuk Rapid n Manhattan B21522248/100236464



## DECO HARLEM ACERO

59,6 cm x 59,6 cm x 1,1 cm	
P1856926 / 100145489	G359

Butech: Colorstuk Rapid n Manhattan B21522248/100236464



## HARLEM CALIZA

80 cm x 80 cm x 1,2 cm	P1760061 / 100145837	G369	HIGHKER
59,6 cm x 59,6 cm x 1,1 cm	P1856920 / 100145387	G354	

Butech: Colorstuk Rapid n Gris B21522258/100236834



## DECO HARLEM CALIZA

59,6 cm x 59,6 cm x 1,1 cm	
P1856925 / 100145530	G359

Butech: Colorstuk Rapid n Gris B21522258/100236834

DECO HARLEM ESTÁ FORMADO POR 8 DECORADOS DISTINTOS ALEATORIOS.  
DECO HARLEM RANGE IS MADE IN 8 DIFFERENT RANDOM PATTERNS.

STON-KER



**EMBALAJE / PACKING**

MODELO MODEL	PZ/CJ	M2/CJ	*KG/CJ	CJ/PAL	M2/PAL	*KG/PAL	ADHESIVO ADHESIVE BUTECH
120 cm x 120 cm	1	1,44	38,72	33	47,52	1277,83	One-flex Premium / Super-flex s2
80 cm x 80 cm	2	1,28	33,89	40	51,2	1355,9	One-flex Premium / Super-flex s2
59,6 cm x 59,6 cm	4	1,42	37,24	32	45,47	1127,62	Fr-one n / One-flex Premium
Zócalo 9 cm x 120 cm	6	0,65	7,93	40	25,92	317,28	
Zócalo 9 cm x 80 cm	12	0,86	23,16	42	36,29	972,72	
Zócalo 9 cm x 59,6 cm	18	0,97	23,25	56	54,07	1301,92	
HT 31,6 cm x 59,6 cm	2	0,42	11,33	48	11,33	543,84	
HTE 31,6 cm x 59,6 cm	1	0,21	5,67	48	5,67	271,92	

\*valores aproximados. \*approximated values.

**HUELLA TÉCNICA / STEP TILES**

MODELO MODEL	31,6 cm x 59,6 cm		ESQUINA DE. / R. CORNER		ESQUINA IZ. / L. CORNER	
HARLEM ACERO	P9210221 / 100148481	G130	P9210231 / 100148451	G150	P9210219 / 100148474	G150
HARLEM CALIZA	P9210223 / 100148482	G130	P9210228 / 100148452	G150	P9210218 / 100148475	G150
	31,6 cm x 80 cm	G153		G181		G181
	31,6 cm x 120 cm	G180		G187		G187

**ZÓCALO / SKIRTING BOARDS**

MODELO MODEL	9 cm x 120 cm		9 cm x 80 cm		9 cm x 59,6 cm	
HARLEM ACERO	P4220008 / 100229474	G78	P4160014 / 100148435	G63	P9210210 / 100146861	G30
HARLEM CALIZA			P4160012 / 100148436	G63	P9210209 / 100146862	G30







PAV. / FLOOR TILE: KARACHI ACERO 100 cm x 100 cm

# KARACHI

Gres Porcellanato Rectificado · Color Masa / Rectified Porcellanato Tiles · Coloured Biscuit



**NEW**



## KARACHI ACERO

100 cm x 100 cm x 1,2 cm P3590025 / 100272129 G377 HIGHKER

Butech: Colorstuk Rapid n Cemento B21522249/100236449



## KARACHI GREY

100 cm x 100 cm x 1,2 cm P3590022 / 100272180 G377 HIGHKER

Butech: Colorstuk Rapid n Negro B21522251/100236475

### EMBALAJE / PACKING

MODELO MODEL	PZ/CJ	M2/CJ	*KG/CJ	CJ/PAL	M2/PAL	*KG/PAL	ADHESIVO ADHESIVE BUTECH
100 cm x 100 cm	1	1	27,63	33	33	911,88	One-flex Premium / Super-flex s2
Zócalo 9 cm x 100 cm	6	0,54	6,85	40	21,60	273,84	
HT 31,6 cm x 100 cm	2	0,70	18,63	26	18,15	484	
HTE 31,6 cm x 100 cm	1	0,36	9,32	26	9,37	242,19	

\*valores aproximados. \*approximated values.

### HUELLA TÉCNICA / STEP TILES

MODELO MODEL	31,6 cm x 100 cm	ESQUINA DE. / R. CORNER	ESQUINA IZ. / L. CORNER
KARACHI ACERO	P9210892 / 100274513 G164	P9210893 / 100274485 G183	P9210889 / 100274448 G183
KARACHI GREY	P9210891 / 100274523 G164	P9210894 / 100274493 G183	P9210890 / 100274531 G183

### ZÓCALO / SKIRTING BOARDS

MODELO MODEL	9 cm x 100 cm
KARACHI ACERO	P9203328 / 100274480 G74
KARACHI GREY	P9203325 / 100274466 G74





PAV. / FLOOR TILE: MÉXICO CALIZA 59,6 cm x 59,6 cm

## MÉXICO

Gres Porcelanato Rectificado · Color Masa / Rectified Porcellanato Tiles · Coloured Biscuit



### MÉXICO CALIZA

59,6 cm x 59,6 cm x 1,03 cm

P1857079 / 100226520 G354

Butech: Colorstuk Rapid n Gris B21522258/100236834

### EMBALAJE / PACKING

MODELO MODEL	PZ/CJ	M2/CJ	*KG/CJ	CJ/PAL	M2/PAL	*KG/PAL	ADHESIVO ADHESIVE BUTECH
59,6 cm x 59,6 cm	4	1,42	34,47	32	45,47	1102,98	Fr-one n / One-flex Premium
Zócalo 9 cm x 59,6 cm	18	0,97	22,77	56	54,07	1275,12	
HT 31,6 cm x 59,6 cm	2	0,42	12	48	19,97	576	
HTE 31,6 cm x 59,6 cm	1	0,21	6	48	10,54	288	

\*valores aproximados. \*approximated values.

### HUELLA TÉCNICA / STEP TILES

MODELO MODEL	31,6 cm x 59,6 cm	ESQUINA DE. / R. CORNER	ESQUINA IZ. / L. CORNER
MÉXICO CALIZA	P9210651 / 100227280 G130	P9210654 / 100227274 G150	P9210644 / 100227300 G150

### ZÓCALO / SKIRTING BOARDS

MODELO MODEL	9 cm x 59,6 cm
MÉXICO CALIZA	P9210637 / 100227264 G30



# MICROCEMENTO BLANCO

Gres Porcellanato Rectificado · Color Masa / Rectified Porcellanato Tiles · Coloured Biscuit



## MICROCEMENTO BLANCO

59,6 cm x 59,6 cm x 1,1 cm

P1856883 / 100137638 G354

Butech: Colorstuk Rapid n Gris B21522258/100236834

### EMBALAJE / PACKING

MODELO MODEL	PZ/CJ	M2/CJ	*KG/CJ	CJ/PAL	M2/PAL	*KG/PAL	ADHESIVO ADHESIVE BUTECH
59,6 cm x 59,6 cm	4	1,42	37,24	32	45,47	1127,62	Fr-one n / One-flex Premium
Zócalo 9 cm x 59,6 cm	18	0,97	23,25	56	54,07	1301,92	
HT 31,6 cm x 59,6 cm	2	0,42	11,33	48	19,97	543,84	
HTE 31,6 cm x 59,6 cm	1	0,21	5,67	48	9,98	271,92	

\*valores aproximados. \*approximated values.

### HUELLA TÉCNICA / STEP TILES

MODELO MODEL	31,6 cm x 59,6 cm		ESQUINA DE. / R. CORNER		ESQUINA IZ. / L. CORNER	
MICROCEMENTO B.	P9210054 / 100122113	G130	P9210112 / 100122977	G150	P9210099 / 100123011	G150

### ZÓCALO / SKIRTING BOARDS

MODELO MODEL	9 cm x 59,6 cm	
MICROCEMENTO B.	P9210157 / 100138023	G30





# NANTES BOMBAY

Gres Porcellanato Rectificado · Color Masa / Rectified Porcellanato Tiles · Coloured Biscuit



## NANTES ACERO

120 cm x 120 cm x 1,15 cm P9202151 / 100239912 G392 HIGHKER   
59,6 cm x 59,6 cm x 1,03 cm P1857098 / 100239867 G354

## NANTES ACERO ANTISLIP

59,6 cm x 59,6 cm x 1,03 cm P1857112 / 100243332 G359  
Butech: Colorstuk Rapid n Gris B21522258/100236834



## NANTES CALIZA

120 cm x 120 cm x 1,15 cm P9202152 / 100239891 G392 HIGHKER   
59,6 cm x 59,6 cm x 1,03 cm P18570989 / 100239881 G354

## NANTES CALIZA ANTISLIP

59,6 cm x 59,6 cm x 1,03 cm P1857111 / 100243311 G359  
Butech: Colorstuk Especial n Nacare B24302057/100238235



## NANTES ARENA

59,6 cm x 59,6 cm x 1,03 cm  
P1857096 / 100239839 G354

## NANTES ARENA ANTISLIP

59,6 cm x 59,6 cm x 1,03 cm  
P1857115 / 100243333 G359

Butech: Colorstuk Rapid n Beige B21522252/100236808



## BOMBAY NANTES

59,6 cm x 59,6 cm x 1,03 cm  
P1857094 / 100239819 G359

Butech: Colorstuk Rapid n Manhattan B21522248/100236464

BOMBAY NANTES ESTÁ FORMADA POR 10 DECORADOS DISTINTOS ALEATORIOS.  
BOMBAY NANTES IS MADE IN 10 DIFFERENT RANDOM PATTERNS.





#### EMBALAJE / PACKING

MODELO MODEL	PZ/CJ	M2/CJ	*KG/CJ	CJ/PAL	M2/PAL	*KG/PAL	ADHESIVO ADHESIVE BUTECH
120 cm x 120 cm	1	1,44	38,72	33	47,52	1277,83	One-flex Premium / Super-flex s2
59,6 cm x 59,6 cm	4	1,42	34,38	32	45,47	1100,03	Fr-one n / One-flex Premium
Zócalo 9 cm x 120 cm	6	0,65	8,22	40	25,92	328,8	
Zócalo 9 cm x 59,6 cm	18	0,97	22,77	56	54,07	1275,12	
HT 31,6 cm x 120 cm	2	0,84	22,36	26	21,78	581,26	
HTE 31,6 cm x 120 cm	1	0,43	11,18	26	11,19	290,63	
HT 31,6 cm x 59,6 cm	2	0,42	12	48	19,97	576	
HTE 31,6 cm x 59,6 cm	1	0,22	6	48	10,54	288	

\*valores aproximados. \*approximated values.

#### HUELLA TÉCNICA / STEP TILES



MODELO MODEL	31,6 cm x 120 cm	ESQUINA DE. / R. CORNER	ESQUINA IZ. / L. CORNER
NANTES ACERO	P8670252 / 100242272 G180	P8670264 / 100242252 G187	P8670271 / 100242218 G187
NANTES CALIZA	P86702581 / 100242256 G180	P8670273 / 100242217 G187	P8670272 / 100242219 G187

MODELO MODEL	31,6 cm x 59,6 cm	ESQUINA DE. / R. CORNER	ESQUINA IZ. / L. CORNER
NANTES ACERO	P9210723 / 100242276 G130	P9210719 / 100242310 G150	P9210715 / 100242309 G150
N. ACERO ANT.	P9210772 / 100246537 G130	P9210761 / 100246514 G150	P9210769 / 100246513 G150
NANTES CALIZA	P9210725 / 100242277 G130	P9210712 / 100242311 G150	P9210704 / 100242275 G150
N. CALIZA ANT.	P9210774 / 100246574 G130	P9210762 / 100246515 G150	P9210771 / 100246529 G150
NANTES ARENA	P9210718 / 100242296 G130	P9210722 / 100242294 G150	P9210727 / 100242320 G150
N. ARENA ANT.	P9210773 / 100246581 G130	P9210760 / 100246478 G150	P9210770 / 100246509 G150

#### ZÓCALO / SKIRTING BOARDS



MODELO MODEL	9 cm x 120 cm	9 cm x 59,6 cm
NANTES ACERO	P4220014 / 100242355 G78	P9210738 / 100242338 G30
NANTES CALIZA	P4220010 / 100242380 G78	P9210741 / 100242381 G30
NANTES ARENA		P9210733 / 100242373 G30



# PARK

Gres Porcellanato Rectificado · Color Masa / Rectified Porcellanato Tiles · Coloured Biscuit

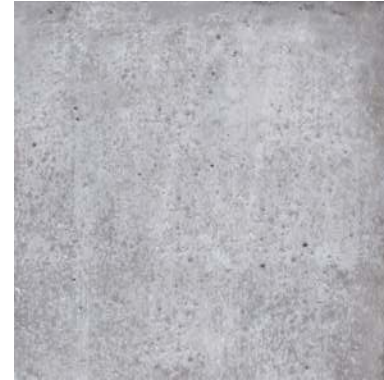

## PARK ACERO

59,6 cm x 59,6 cm x 1,1 cm

P1856927 / 100145726 G354

Butech: Colorstuk Rapid n Manhattan B21522248/100236464

# ANTIQUE

Gres Porcellanato Rectificado · Color Masa / Rectified Porcellanato Tiles · Coloured Biscuit



## ANTIQUE ACERO

59,6 cm x 59,6 cm x 1,1 cm

P1856935 / 100147629 G359

Butech: Colorstuk Rapid n Manhattan B21522248/100236464



## ANTIQUE BLACK

59,6 cm x 59,6 cm x 1,1 cm

P1856931 / 100145842 G359

Butech: Colorstuk Rapid n Negro B21522251/100236475

ANTIQUE ACERO AND BLACK ESTÁ FORMADO POR 6 DECORADOS DISTINTOS ALEATORIOS.  
ANTIQUE ACERO AND BLACK RANGE IS MADE IN 6 DIFFERENT RANDOM PATTERNS.

### EMBALAJE / PACKING

MODELO MODEL	PZ/CJ	M2/CJ	*KG/CJ	CJ/PAL	M2/PAL	*KG/PAL	ADHESIVO ADHESIVE BUTECH
59,6 cm x 59,6 cm	4	1,42	37,24	32	45,47	1127,62	Fr-one n / One-flex Premium
Zócalo 9 cm x 59,6 cm	18	0,97	23,25	56	54,07	1301,92	
HT 31,6 cm x 59,6 cm	2	0,42	11,33	48	19,97	543,84	
HTE 31,6 cm x 59,6 cm	1	0,21	5,67	48	9,98	271,92	

\*valores aproximados. \*approximated values.

### HUELLA TÉCNICA / STEP TILES



MODELO MODEL	31,6 cm x 59,6 cm		ESQUINA DE. / R. CORNER		ESQUINA IZ. / L. CORNER	
PARK ACERO	P9210222 / 100148458	G130	P9210230 / 100148405	G150	P9210215 / 100148454	G150

### ZÓCALO / SKIRTING BOARDS



MODELO MODEL	9 cm x 59,6 cm	
PARK ACERO	P9210207 / 100146859	G30



## ANTIQUE SILVER

59,6 cm x 59,6 cm x 1,1 cm

P1856930 / 100145533 G359

Butech: Colorstuk Rapid n Cemento B21522249/100236449

ANTIQUE SILVER ESTÁ FORMADO POR 10 DECORADOS DISTINTOS ALEATORIOS.  
ANTIQUE SILVER RANGE IS MADE IN 10 DIFFERENT RANDOM PATTERNS.



PAV. / FLOOR TILE: RODANO ACERO 120 cm x 120 cm

# RODANO

Gres Porcellanato Rectificado · Color Masa / Rectified Porcellanato Tiles · Coloured Biscuit



## RODANO ACERO

120 cm x 120 cm x 1,15 cm	P9201769 / 100226489	G392	HIGHKER	
80 cm x 80 cm x 1,2 cm	P1760079 / 100154670	G369	HIGHKER	
59,6 cm x 59,6 cm x 1,1 cm	P1856901 / 100138631	G354		

## RODANO ACERO ANTISLIP

120 cm x 120 cm x 1,15 cm	P9202000 / 100236523	G393	HIGHKER	
59,6 cm x 59,6 cm x 1,1 cm	P1856902 / 100138630	G359		

Butech: Colorstuk Rapid n Manhattan B2152248/100236464



## RODANO CALIZA

59,6 cm x 59,6 cm x 1,1 cm	P1856900 / 100138632	G354		
----------------------------	----------------------	------	--	--

Butech: Colorstuk Rapid n Gris B2152258/100236834



## RODANO SILVER

59,6 cm x 59,6 cm x 1,1 cm	P1856904 / 100138634	G354		
----------------------------	----------------------	------	--	--

## RODANO SILVER ANTISLIP

59,6 cm x 59,6 cm x 1,1 cm	P1856903 / 100138633	G359		
----------------------------	----------------------	------	--	--

Butech: Colorstuk Rapid n Cemento B2152249/100236449





### EMBALAJE / PACKING

MODELO / MODEL	PZ/CJ	M2/CJ	*KG/CJ	CJ/PAL	M2/PAL	*KG/PAL	ADHESIVO / ADHESIVE BUTECH
120 cm x 120 cm	1	1,44	37,37	33	47,52	1233,11	One-flex Premium / Super-flex s2
80 cm x 80 cm	2	1,28	35,7	40	51,2	417,32	One-flex Premium / Super-flex s2
59,6 cm x 59,6 cm	4	1,42	35,24	32	45,47	1127,62	Fr-one n / One-flex Premium
Zócalo 9 cm x 120 cm	6	0,65	7,93	40	25,92	317,28	
Zócalo 9 cm x 80 cm	12	0,86	23,16	42	36,29	972,72	
Zócalo 9 cm x 59,6 cm	18	0,97	23,25	56	54,07	1301,92	
HT 31,6 cm x 59,6 cm	2	0,42	11,33	48	19,97	543,84	
HTE 31,6 cm x 59,6 cm	1	0,21	5,67	48	9,98	271,92	

\*valores aproximados. \*approximated values.

### HUELLA TÉCNICA / STEP TILES

MODELO / MODEL	31,6 cm x 59,6 cm		ESQUINA DE. / R. CORNER		ESQUINA IZ. / L. CORNER	
RODANO ACERO	P9210134 / 100123907	G130	P9210199 / 100140956	G150	P9210133 / 100123908	G150
R. ACERO ANT.	P9210234 / 100148524	G130	P9210232 / 100148522	G150	P9210233 / 100148523	G150
RODANO SILVER	P9210180 / 100138071	G130	P9210179 / 100138029	G150	P9210181 / 100138070	G150
R. SILVER ANT.	P9210242 / 100149822	G130	P9210238 / 100149618	G150	P9210239 / 100149820	G150
RODANO CALIZA	P9210142 / 100130107	G130	P9210202 / 100140957	G150	P9210198 / 100140966	G150
	31,6 cm x 80 cm	G153		G181		G181
	31,6 cm x 120 cm	G180		G187		G187

### ZÓCALO / SKIRTING BOARDS

MODELO / MODEL	9 cm x 120 cm		9 cm x 80 cm		9 cm x 59,6 cm	
RODANO ACERO	P4220005 / 100227271	G78	P4160006 / 100141005	G63	P9210163 / 100138027	G30
RODANO SILVER					P9210150 / 100137975	G30
RODANO CALIZA					P9210151 / 100137974	G30







PAV. / FLOOR TILE: SOHO ACERO 80 cm x 80 cm

## SOHO

Gres Porcellanato Rectificado · Color Masa / Rectified Porcellanato Tiles · Coloured Biscuit

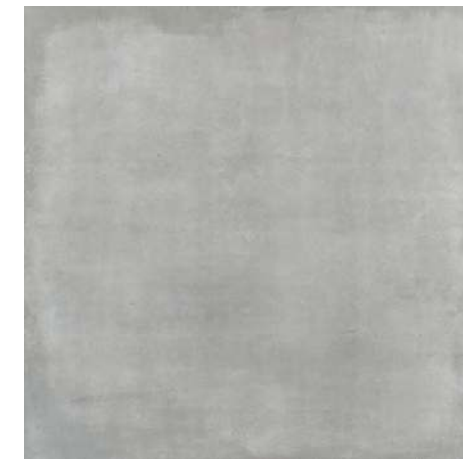

### SOHO ACERO

80 cm x 80 cm x 1,2 cm P1760108 / 100190058 G369 HIGHKER

### SOHO ACERO ANTISLIP

80 cm x 80 cm x 1,2 cm P1857053 / 100202915 G373 HIGHKER

Butech: Colorstuk Rapid n Cemento B21522249/100236449



### EMBALAJE / PACKING

MODELO MODEL	PZ/CJ	M2/CJ	*KG/CJ	CJ/PAL	M2/PAL	*KG/PAL	ADHESIVO ADHESIVE BUTECH
80 cm x 80 cm	2	1,28	35,7	40	51,2	1427,91	One-flex Premium / Super-flex s2
Zócalo 9 cm x 80 cm	12	0,86	23,16	42	36,29	972,72	
HT 31,6 cm x 80 cm	2	0,56	14,58	26	14,52	379,15	
HTE 31,6 cm x 80 cm	1	0,29	7,29	26	7,56	189,57	

\*valores aproximados. \*approximated values.

### HUELLA TÉCNICA / STEP TILES

MODELO MODEL	31,6 cm x 80 cm	ESQUINA DE. / R. CORNER	ESQUINA IZ. / L. CORNER
SOHO ACERO	P9210381 / 100191372 G153	P9210372 / 100191316 G181	P9210371 / 100191334 G181
SOHO ACERO ANT.	P9210450 / 100203864 G153	P9210474 / 100203953 G181	P9210466 / 100203894 G181

### ZÓCALO / SKIRTING BOARDS

MODELO MODEL	9 cm x 59,6 cm
SOHO ACERO	P4160029 / 100191371 G63





# TOSCANA

Gres Porcellanato Rectificado · Color Masa / Rectified Porcellanato Tiles · Coloured Biscuit



## TOSCANA BONE

59,6 cm x 59,6 cm x 1,1 cm

P1857030 / 100190103 G354

Butech: Colorstuk Rapid n Gris B21522258/100236834



## TOSCANA CALIZA

59,6 cm x 59,6 cm x 1,1 cm

P1857031 / 100190077 G354

Butech: Colorstuk Rapid n Gris B21522258/100236834



## TOSCANA STONE

59,6 cm x 59,6 cm x 1,1 cm

P1857029 / 100190065 G354

Butech: Colorstuk Rapid n Gris B21522258/100236834

## EMBALAJE / PACKING

MODELO MODEL	PZ/CJ	M2/CJ	*KG/CJ	CJ/PAL	M2/PAL	*KG/PAL	ADHESIVO ADHESIVE BUTECH
59,6 cm x 59,6 cm	4	1,42	37,24	32	45,47	1127,62	Fr-one n / One-flex Premium
Zócalo 9 cm x 59,6 cm	18	0,97	23,25	56	54,07	1301,92	
HT 31,6 cm x 59,6 cm	2	0,42	11,33	48	19,97	543,84	
HTE 31,6 cm x 59,6 cm	1	0,21	5,67	48	9,98	271,92	

\*valores aproximados. \*approximated values.

## HUELLA TÉCNICA / STEP TILES

MODELO MODEL	31,6 cm x 59,6 cm			ESQUINA DE. / R. CORNER		ESQUINA IZ. / L. CORNER			
TOSCANA BONE	P9210419	/ 100193839	G130	P9210392	/ 100191339	G150	P9210393	/ 100191347	G150
TOSCANA CALIZA	P9210414	/ 100193826	G130	P9210390	/ 100191370	G150	P9210416	/ 100193827	G150
TOSCANA STONE	P9210415	/ 100193850	G130	P9210391	/ 100191363	G150	P9210417	/ 100193829	G150

## ZÓCALO / SKIRTING BOARDS

MODELO MODEL	9 cm x 59,6 cm		
TOSCANA BONE	P9210442	/ 100193877	G30
TOSCANA CALIZA	P9210432	/ 100193881	G30
TOSCANA STONE	P9210435	/ 100193882	G30



PAV. / FLOOR TILE: EXTREME WHITE 59,6 cm x 59,6 cm

## EXTREME

Gres Porcellanato Rectificado · Color Masa / Rectified Porcellanato Tiles · Coloured Biscuit

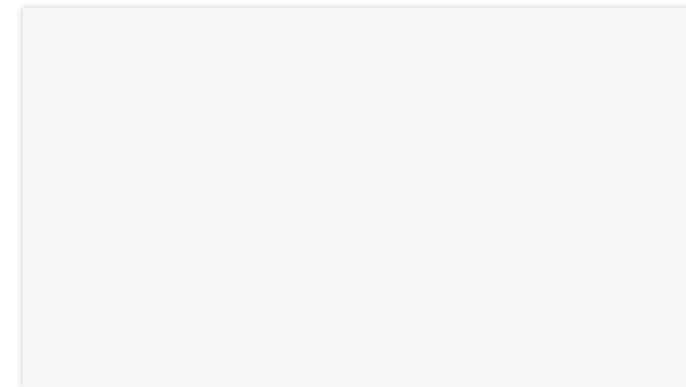

### EXTREME WHITE

59,6 cm x 120 cm x 1,2 cm P1976829 / 100158512 G369

Butech: Colorstuk Rapid n Blanco B21522247/100236463

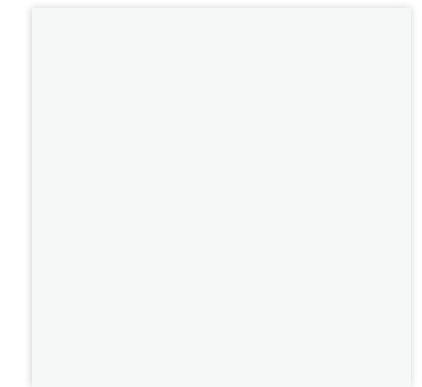

### EXTREME WHITE

59,6 cm x 59,6 cm x 1,1 cm

P1856874 / 100137635 G354

Butech: Colorstuk Rapid n Blanco B21522247/100236463

HIGHKER

### EMBALAJE / PACKING

MODELO MODEL	PZ/CJ	M2/CJ	*KG/CJ	CJ/PAL	M2/PAL	*KG/PAL	ADHESIVO ADHESIVE BUTECH
59,6 cm x 120cm	2	1,43	39,14	28	40,05	1095,92	One-flex Premium / Super-flex s2
59,6 cm x 59,6 cm	4	1,42	35,24	32	45,47	1127,62	Fr-one n / One-flex Premium
Zócalo 9 cm x 59,6 cm	18	0,97	23,25	56	54,07	1301,92	
Zócalo 9 cm x 120 cm	6	0,65	7,93	40	25,92	317,28	
HT 31,6 cm x 59,6 cm	2	0,42	11,33	48	19,97	543,84	
HTE 31,6 cm x 59,6 cm	1	0,21	5,67	48	9,98	271,92	

\*valores aproximados. \*approximated values.

### HUELLA TÉCNICA / STEP TILES

MODELO MODEL	31,6 cm x 120 cm	ESQUINA DE. / R. CORNER	ESQUINA IZ. / L. CORNER
EXTREME WHITE	P8670063 / 100128966 G180	P98670154 / 100173439 G187	P8670156 / 100173472 G187

MODELO MODEL	31,6 cm x 59,6 cm	ESQUINA DE. / R. CORNER	ESQUINA IZ. / L. CORNER
EXTREME WHITE	P9210060 / 100122103 G130	P9210088 / 100122966 G150	P9210097 / 100123000 G150

### ZÓCALO / SKIRTING BOARDS

MODELO MODEL	9 cm x 120 cm	9 cm x 59,6 cm
EXTREME WHITE	P4220017 / 100234892 G78	P9210327 / 100176831 G30





PAV. / FLOOR TILE: MATT WHITE 59,6 cm x 59,6 cm

## MATT

Gres Porcellanato Rectificado · Color Masa / Rectified Porcellanato Tiles · Coloured Biscuit

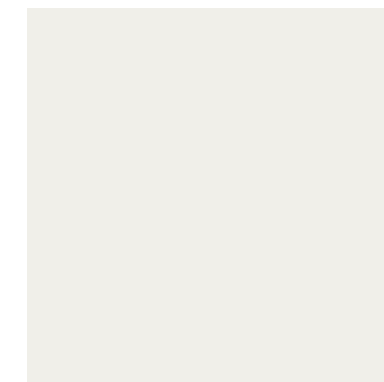

### MATT WHITE

59,6 cm x 59,6 cm x 1,03 cm

P1857101 / 100239880 G354

Butech: Colorstuk Rapid n Blanco B2152247/100236463

### EMBALAJE / PACKING

MODELO MODEL	PZ/CJ	M2/CJ	*KG/CJ	CJ/PAL	M2/PAL	*KG/PAL	ADHESIVO ADHESIVE BUTECH
59,6 cm x 59,6 cm	4	1,42	37,24	32	45,47	1127,62	Fr-one n / One-flex Premium
Zócalo 9 cm x 59,6 cm	18	0,97	23,25	56	54,07	1301,92	
HT 31,6 cm x 59,6 cm	2	0,42	11,33	48	19,97	543,84	
HTE 31,6 cm x 59,6 cm	1	0,22	5,67	48	9,98	271,92	

\*valores aproximados. \*approximated values.

### HUELLA TÉCNICA / STEP TILES

MODELO MODEL	31,6 cm x 59,6 cm	ESQUINA DE. / R. CORNER	ESQUINA IZ. / L. CORNER
MATT WHITE	P9210726 / 100242330 G130	P9210729 / 100242305 G150	P9210721 / 100242308 G150

### ZÓCALO / SKIRTING BOARDS

MODELO MODEL	9 cm x 59,6 cm
MATT WHITE	P92107391 / 100242346 G30



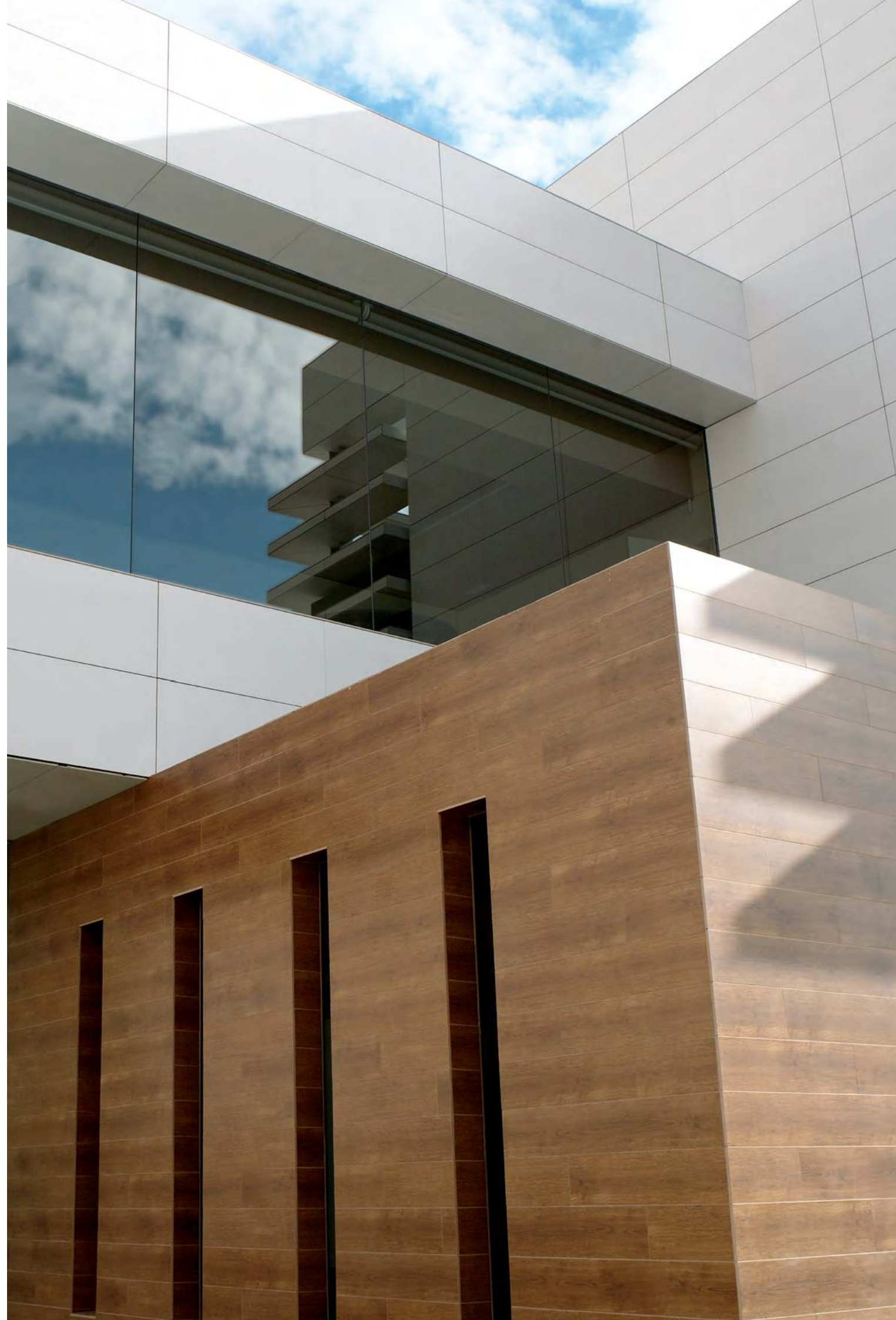

PAV. / WALL TILE: TECHNIG NIEVE 59,6 cm x 120 cm

# TECHNIC

Gres Porcellanato Rectificado · Color Masa / Rectified Porcellanato Tiles · Coloured Biscuit

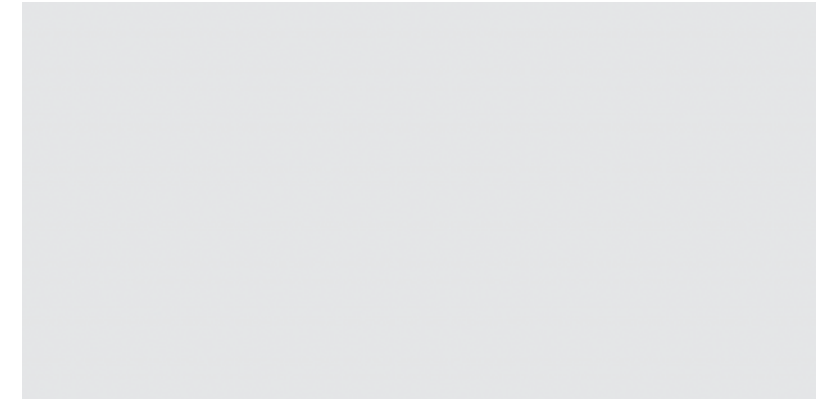

**TECHNIC NIEVE**

59,6 cm x 120 cm x 1,2 cm P1976817 / 100153392 G369

Butech: Colorstuk Rapid n Blanco B21522247/100236463

HIGHKER

\*USO EXCLUSIVO PARA FACHADAS  
\*FACADES USE ONLY

**EMBALAJE / PACKING**

MODELO MODEL	PZ/CJ	M2/CJ	*KG/CJ	CJ/PAL	M2/PAL	*KG/PAL	ADHESIVO ADHESIVE BUTECH
59,6 cm x 120 cm	2	1,43	39,14	28	40,05	1095,92	One-flex Premium / Super-flex s2

\*valores aproximados. \*approximated values.





PAV. / FLOOR TILE: BARCELONA C 59,6 cm x 59,6 cm

# BARCELONA

Gres Porcellanato Rectificado · Color Masa / Rectified Porcellanato Tiles · Coloured Biscuit

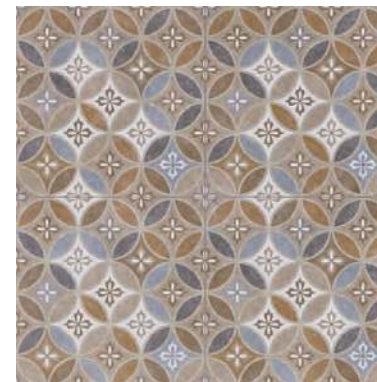

## BARCELONA B

59,6 cm x 59,6 cm x 1,1 cm

P1856961 / 100155910 G359

Butech: Colorstuk Rapid n Cemento B21522249/100236449



## BARCELONA C

59,6 cm x 59,6 cm x 1,1 cm

P1856959 / 100155911 G359

Butech: Colorstuk Rapid n Antracita B21522250/100236481



## BARCELONA D

59,6 cm x 59,6 cm x 1,1 cm

P1856960 / 100155912 G359

Butech: Colorstuk Rapid n Gris B21522258/100236834



## BARCELONA E

59,6 cm x 59,6 cm x 1,1 cm

P1856975 / 100161220 G359

Butech: Colorstuk Rapid n Cemento B21522249/100236449

BARCELONA D, E ESTÁN FORMADOS POR 8 DECORADOS DISTINTOS ALEATORIOS.  
BARCELONA D,E,F RANGES ARE MADE IN 8 DIFFERENT RANDOM PATTERNS.

### EMBALAJE / PACKING

MODELO MODEL	PZ/CJ	M2/CJ	*KG/CJ	CJ/PAL	M2/PAL	*KG/PAL	ADHESIVO ADHESIVE BUTECH
59,6 cm x 59,6 cm	4	1,42	35,4	32	45,47	1132,38	Fr-one n / One-flex Premium

\*valores aproximados. \*approximated values.





PAV. / FLOOR TILE: SAFARI ARENA 59,6 cm x 59,6 cm

# SAFARI

Gres Porcellanato Rectificado · Color Masa / Rectified Porcellanato Tiles · Coloured Biscuit



## SAFARI ARENA

59,6 cm x 59,6 cm x 1,1 cm

P1856987 / 100172718 G354

Butech: Colorstuk Rapid n Beige B2152252/100236808

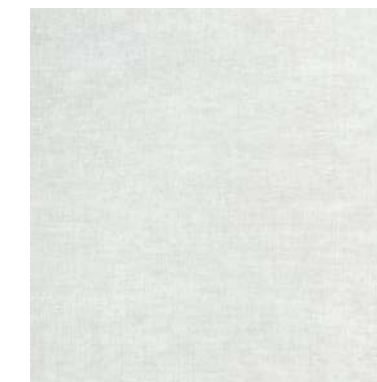

## SAFARI CALIZA

59,6 cm x 59,6 cm x 1,1 cm

P1856986 / 100172735 G354

Butech: Colorstuk Rapid n Marfil B2152257/100236794

### EMBALAJE / PACKING

MODELO MODEL	PZ/CJ	M2/CJ	*KG/CJ	CJ/PAL	M2/PAL	*KG/PAL	ADHESIVO ADHESIVE BUTECH
59,6 cm x 59,6 cm	4	1,42	35,20	32	45,47	1094,41	Fr-one n / One-flex Premium
Zócalo 9 cm x 59,6 cm	18	0,97	22,64	56	54,07	1267,69	
HT 31,6 cm x 59,6 cm	2	0,42	11,33	48	19,97	543,84	
HTE 31,6 cm x 59,6 cm	1	0,21	5,67	48	9,98	271,92	

\*valores aproximados. \*approximated values.

### HUELLA TÉCNICA / STEP TILES

MODELO MODEL	31,6 cm x 59,6 cm	ESQUINA DE. / R. CORNER	ESQUINA IZ. / L. CORNER
SAFARI ARENA	P9210311 / 100173541 G130	P9210312 / 100173517 G150	P9210314 / 100173509 G150
SAFARI CALIZA	P9210317 / 100173561 G130	P9210319 / 100173508 G150	P9210315 / 100173540 G150

### ZÓCALO / SKIRTING BOARDS

MODELO MODEL	9 cm x 59,6 cm
SAFARI ARENA	P9200883 / 100173557 G30
SAFARI CALIZA	P9200885 / 100173589 G30

GRUPO DE VENTA MALLA STONKER 31,6 cm x 31,6 cm ( ESPECIAL ZONAS AGUA ) G396

SALES GROUP STONKER MESH 31,6 cm x 31,6 cm (SPECIAL WATER ZONES) G396

**GRUPOS DE VENTA FACHADAS / FACADE PRICE GROUP**

FORMATO / SIZE		FORMATO / SIZE		FORMATO / SIZE		FORMATO / SIZE		FORMATO / SIZE	
43,5x65,9 rn4	G415	59,6x59,6 rn4	G420	59,6x120 rn4	G462	45x90 rn4	G432	19,3x120 rn4 / 19,3xmll	G483
43,5x65,9 mll	G435	59,6x59,6 mll	G440	59,6x120 rn6	G467	45x90 mll	G458	19,3x120 rn6	G490
43,5x65,9 mll + rn4	G446	59,6x59,6 mll+rn4	G455	59,6x120 mll / 80x80 mll	G479	45x90 mll + rn4	G473	19,3x120 mll + rn6	G494
				59,6x120 mll + rn4 ver	G484				
				59,6x120 mll + rn6 hor	G488				

GRUPO DE VENTA MALLA STONKER 31,6 cm x 31,6 cm ( ESPECIAL ZONAS AGUA ) G396

SALES GROUP STONKER MESH 31,6 cm x 31,6 cm (SPECIAL WATER ZONES) G396

DETALLE HUELLA CON REFUERZO METÁLICO

DETAIL WITH METAL REINFORCEMENT

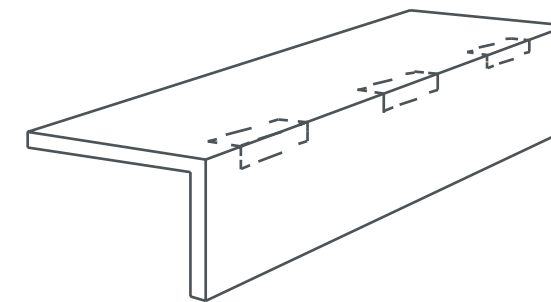

"La H.T. con refuerzo metálico puede fabricarse a la medida solicitada por el cliente, siempre y cuando no supere los límites longitudinales de la pieza base".

"The S.T. with metal reinforcement can be made to order as requested by the customer, as long as it does not exceed the longitudinal limits of the base part".





Mármoles, calizas, areniscas o superficies cementosas y metálicas se transforman en pavimentos cerámicos que recubren de personalidad espacios sublimes.

## **PAVIMEN- TOS**

*Marble, limestone, sandstone and cementitious or metallic surfaces transform ceramic floorings which cover sublime spaces in personality.*

## **FLOOR TILES**



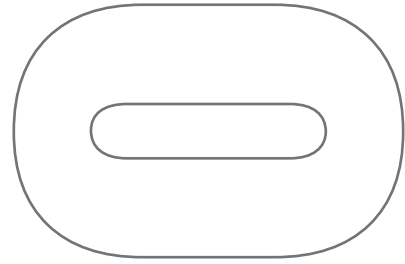

## POLISHED

BIANCO PULIDO	285
CARRARA BLANCO PULIDO	287
MARVEL PULIDO	289 <b>NEW</b>
PORTOFINO PULIDO	291
ROYAL PULIDO	293
SOCHI PULIDO	295
VERONA PULIDO	297

## PORCELLANATO TILES

CARRARA BLANCO NATURAL	298
BOTTEGA	299
MEAUX	300

## RECTIFIED TILES

BARI BLANCO	301
CALACATA	302
CARRARA BLANCO BRILLO	303
FONTANA	304 <b>NEW</b>
MILANO	305
OLIMPO MARFIL	306
PERSIA	307
RECIFE GRIS	308
SENA	309
THASSOS	310
TRAVERTINO MEDICI	311
MARMI BLANCO	312

## 44,3 cm x 44,3 cm TILES

BOTTEGA	313
DOVER	314
NANTES	315 <b>NEW</b>
NAST	316
NIMBUS	317
PARK	318
RODANO	319
CARRARA BLANCO BRILLO	320
FONTANA MATT	321 <b>NEW</b>
NOVA	322 <b>NEW</b>
JAPAN	323



## BIANCO PULIDO

Gres Porcellanato Rectificado · Pulido / Rectified Porcellanato Tiles · Polished



### BIANCO PULIDO

58,6 cm x 118,7 cm x 1,15 cm P2620000 / 100226490 G389

Butech: Colorstuk Especial n Nacaré B24302057/100238235

HIGHKER

- Uso exclusivo para tránsito peatonal moderado.
- Proteger el material durante la instalación, se recomienda BUTECH PROTECT.
- Instalar sistemas de retención de suciedad en los accesos para evitar que las partículas abrasivas puedan dañar la superficie.
- Utilizar productos de limpieza neutros en el mantenimiento periódico.
- Exclusive use for moderate pedestrian traffic.
- BUTECH PROTECT is recommended for the protection during the installation.
- Install dirt retention systems in the accesses to avoid that the abrasive particles can damage the surface.
- Use neutral cleaning products in periodic maintenance.

### EMBALAJE / PACKING

MODELO MODEL	PZ/CJ	M2/CJ	*KG/CJ	CJ/PAL	M2/PAL	*KG/PAL	ADHESIVO ADHESIVE BUTECH
58,6 cm x 118,7 cm	2	1,39	38,30	28	38,95	1072,34	One -flex premium / Super-flex s2
Zócalo 9 cm x 118,7 cm	6	0,64	8,22	40	25,63	328,8	

\*valores aproximados. \*approximated values.

### HUELLA TÉCNICA / STEP TILES

MODELO MODEL	31,6 cm x 118,7 cm	ESQUINA DE. / R. CORNER	ESQUINA IZ. / L. CORNER
BIANCO PULIDO	G184	G194	G194

### ZÓCALO / SKIRTING BOARDS

MODELO MODEL	9 cm x 118,7 cm
BIANCO PULIDO	P4328121 / 100252830 G80



# CARRARA BLANCO PULIDO

Gres Porcellanato Rectificado · Pulido / Rectified Porcellanato Tiles · Polished



## CARRARA BLANCO PULIDO

58,6 cm x 118,7 cm x 1,15 cm P2620002 / 100229356 G389

Butech: Colorstuk Especial n Nacaré B24302057/100238235

HIGHKER

- Uso exclusivo para tránsito peatonal moderado.
- Proteger el material durante la instalación, se recomienda BUTECH PROTECT.
- Instalar sistemas de retención de suciedad en los accesos para evitar que las partículas abrasivas puedan dañar la superficie.
- Utilizar productos de limpieza neutros en el mantenimiento periódico.
- Exclusive use for moderate pedestrian traffic.
- BUTECH PROTECT is recommended for the protection during the installation.
- Install dirt retention systems in the accesses to avoid that the abrasive particles can damage the surface.
- Use neutral cleaning products in periodic maintenance.

## EMBALAJE / PACKING

MODELO MODEL	PZ/CJ	M2/CJ	*KG/CJ	CJ/PAL	M2/PAL	*KG/PAL	ADHESIVO ADHESIVE BUTECH
58,6 cm x 118,7 cm	2	1,39	38,30	28	38,95	1072,34	One-flex premium / Super-flex s2
Zócalo 9 cm x 118,7 cm	6	0,64	8,22	40	25,63	328,8	

\*valores aproximados. \*approximated values.

## HUELLA TÉCNICA / STEP TILES

MODELO MODEL	31,6 cm x 118,7 cm	ESQUINA DE. / R. CORNER	ESQUINA IZ. / L. CORNER
CARRARA BLANCO PUL.	G184	G194	G194

## ZÓCALO / SKIRTING BOARDS

MODELO MODEL	9 cm x 118,7 cm
CARRARA BLANCO PUL.	P4328123 / 100252831 G80



PAV. / FLOOR TILE: MARVEL PULIDO 58,6 cm x 118,7 cm

# MARVEL PULIDO

Gres Porcellanato Rectificado · Pulido / Rectified Porcellanato Tiles · Polished



**NEW**



## MARVEL PULIDO

58,6 cm x 118,7 cm x 1,15 cm P2620008 / 100272168 G389

HIGHKER

Butech: Colorstuk Especial n Nacaré B24302057/100238235

- Uso exclusivo para tránsito peatonal moderado.
- Proteger el material durante la instalación, se recomienda BUTECH PROTECT.
- Instalar sistemas de retención de suciedad en los accesos para evitar que las partículas abrasivas puedan dañar la superficie.
- Utilizar productos de limpieza neutros en el mantenimiento periódico.
- Exclusive use for moderate pedestrian traffic.
- BUTECH PROTECT is recommended for the protection during the installation.
- Install dirt retention systems in the accesses to avoid that the abrasive particles can damage the surface.
- Use neutral cleaning products in periodic maintenance.

## EMBALAJE / PACKING

MODELO MODEL	PZ/CJ	M2/CJ	*KG/CJ	CJ/PAL	M2/PAL	*KG/PAL	ADHESIVO ADHESIVE BUTECH
58,6 cm x 118,7 cm	2	1,39	38,30	28	38,95	1072,34	One -flex premium / Super-flex s2
Zócalo 9 cm x 118,7 cm	6	0,64	8,22	40	25,63	328,8	

\*valores aproximados. \*approximated values.

## HUELLA TÉCNICA / STEP TILES

MODELO MODEL	31,6 cm x 118,7 cm	ESQUINA DE. / R. CORNER	ESQUINA IZ. / L. CORNER
MARVEL PULIDO	G184	G194	G194

## ZÓCALO / SKIRTING BOARDS

MODELO MODEL	9 cm x 118,7 cm
MARVEL PULIDO	P4328126 / 100274437 G80





# PORTOFINO PULIDO

Gres Porcellanato Rectificado · Pulido / Rectified Porcellanato Tiles · Polished



## PORTOFINO PULIDO

58,6 cm x 118,7 cm x 1,15 cm P2620001 / 100226509 G389

HIGHKER

Butech: Colorstuk Especial n Nacaré B24302057/100238235

- Uso exclusivo para tránsito peatonal moderado.
- Proteger el material durante la instalación, se recomienda BUTECH PROTECT.
- Instalar sistemas de retención de suciedad en los accesos para evitar que las partículas abrasivas puedan dañar la superficie.
- Utilizar productos de limpieza neutros en el mantenimiento periódico.
- Exclusive use for moderate pedestrian traffic.
- BUTECH PROTECT is recommended for the protection during the installation.
- Install dirt retention systems in the accesses to avoid that the abrasive particles can damage the surface.
- Use neutral cleaning products in periodic maintenance.

## EMBALAJE / PACKING

MODELO MODEL	PZ/CJ	M2/CJ	*KG/CJ	CJ/PAL	M2/PAL	*KG/PAL	ADHESIVO ADHESIVE BUTECH
58,6 cm x 118,7 cm	2	1,39	38,30	28	38,95	1072,34	One -flex premium / Super-flex s2
Zócalo 9 cm x 118,7 cm	6	0,64	8,22	40	25,63	328,8	

\*valores aproximados. \*approximated values.

## HUELLA TÉCNICA / STEP TILES

MODELO MODEL	31,6 cm x 118,7 cm	ESQUINA DE. / R. CORNER	ESQUINA IZ. / L. CORNER
PORTOFINO PUL.	G184	G194	G194

## ZÓCALO / SKIRTING BOARDS

MODELO MODEL	9 cm x 118,7 cm
PORTOFINO PUL.	P92020561 / 100239120 G80

PAV. / FLOOR TILE: PORTOFINO PULIDO 58,6 cm x 118,7 cm



## ROYAL PULIDO

Gres Porcellanato Rectificado · Pulido / Rectified Porcellanato Tiles · Polished



### ROYAL PULIDO

58,6 cm x 118,7 cm x 1,15 cm P2620005 / 100245329 G389

Butech: Colorstuk Rapid n Perla B21522263/100275760

HIGHER

- Uso exclusivo para tránsito peatonal moderado.
- Proteger el material durante la instalación, se recomienda BUTECH PROTECT.
- Instalar sistemas de retención de suciedad en los accesos para evitar que las partículas abrasivas puedan dañar la superficie.
- Utilizar productos de limpieza neutros en el mantenimiento periódico.
- Exclusive use for moderate pedestrian traffic.
- BUTECH PROTECT is recommended for the protection during the installation.
- Install dirt retention systems in the accesses to avoid that the abrasive particles can damage the surface.
- Use neutral cleaning products in periodic maintenance.

### EMBALAJE / PACKING

MODELO MODEL	PZ/CJ	M2/CJ	*KG/CJ	CJ/PAL	M2/PAL	*KG/PAL	ADHESIVO ADHESIVE BUTECH
58,6 cm x 118,7 cm	2	1,39	38,30	28	38,95	1072,34	One -flex premium / Super-flex s2
Zócalo 9 cm x 118,7 cm	6	0,64	8,22	40	25,63	328,8	

\*valores aproximados. \*approximated values.

### HUELLA TÉCNICA / STEP TILES

MODELO MODEL	31,6 cm x 118,7 cm	ESQUINA DE. / R. CORNER	ESQUINA IZ. / L. CORNER
ROYAL PULIDO	G184	G194	G194

### ZÓCALO / SKIRTING BOARDS

MODELO MODEL	9 cm x 118,7 cm
ROYAL PULIDO	P4328124 / 100252422 G80





# SOCHI PULIDO

Gres Porcellanato Rectificado · Pulido / Rectified Porcellanato Tiles · Polished



## SOCHI MARFIL PULIDO

58,6 cm x 118,7 cm x 1,15 cm P2620004 / 100233198 G389

Butech: Colorstuk Especial n Maple B51201055/100243271

HIGHKER



## SOCHI BLANCO PULIDO

58,6 cm x 118,7 cm x 1,15 cm P2620003 / 100233179 G389

Butech: Colorstuk Especial n Maple B51201055/100243271

HIGHKER

### EMBALAJE / PACKING

MODELO / MODEL	PZ/CJ	M2/CJ	*KG/CJ	CJ/PAL	M2/PAL	*KG/PAL	ADHESIVO / ADHESIVE BUTECH
58,6 cm x 118,7 cm	2	1,39	38,30	28	38,95	1072,34	One -flex premium / Super-flex s2
Zócalo 9 cm x 118,7 cm	6	0,64	8,22	40	25,63	328,8	

\*valores aproximados. \*approximated values.

- Uso exclusivo para tránsito peatonal moderado.
- Proteger el material durante la instalación, se recomienda BUTECH PROTECT.
- Instalar sistemas de retención de suciedad en los accesos para evitar que las partículas abrasivas puedan dañar la superficie.
- Utilizar productos de limpieza neutros en el mantenimiento periódico.
- Exclusive use for moderate pedestrian traffic.
- BUTECH PROTECT is recommended for the protection during the installation.
- Install dirt retention systems in the accesses to avoid that the abrasive particles can damage the surface.
- Use neutral cleaning products in periodic maintenance.

### HUELLA TÉCNICA / STEP TILES

MODELO / MODEL	31,6 cm x 118,7 cm	ESQUINA DE. / R. CORNER	ESQUINA IZ. / L. CORNER
SOCHI MARFIL PUL.		G184	G194
SOCHI BLANCO PUL.		G184	G194

### ZÓCALO / SKIRTING BOARDS

MODELO / MODEL	9 cm x 118,7 cm
SOCHI MARFIL PUL.	P4328120 / 100253040 G80
SOCHI BLANCO PUL.	P4328125 / 100252832 G80



## VERONA PULIDO

Gres Porcellanato Rectificado · Pulido / Rectified Porcellanato Tiles · Polished



### VERONA PULIDO

58,6 cm x 118,7 cm x 1,15 cm P2620006 / 100245349 G389

Butech: Colorstuk Especial n Maple B51201055/100243271

HIGHKER

- Uso exclusivo para tránsito peatonal moderado.
- Proteger el material durante la instalación, se recomienda BUTECH PROTECT.
- Instalar sistemas de retención de suciedad en los accesos para evitar que las partículas abrasivas puedan dañar la superficie.
- Utilizar productos de limpieza neutros en el mantenimiento periódico.
- Exclusive use for moderate pedestrian traffic.
- BUTECH PROTECT is recommended for the protection during the installation.
- Install dirt retention systems in the accesses to avoid that the abrasive particles can damage the surface.
- Use neutral cleaning products in periodic maintenance.

### EMBALAJE / PACKING

MODELO MODEL	PZ/CJ	M2/CJ	*KG/CJ	CJ/PAL	M2/PAL	*KG/PAL	ADHESIVO ADHESIVE BUTECH
58,6 cm x 118,7 cm	2	1,39	38,30	28	38,95	1072,34	One -flex premium / Super-flex s2
Zócalo 9 cm x 118,7 cm	6	0,64	8,22	40	25,63	328,8	

\*valores aproximados. \*approximated values.

### HUELLA TÉCNICA / STEP TILES

MODELO MODEL	31,6 cm x 118,7 cm	ESQUINA DE. / R. CORNER	ESQUINA IZ. / L. CORNER
VERONA PULIDO	G184	G194	G194

### ZÓCALO / SKIRTING BOARDS

MODELO MODEL	9 cm x 118,7 cm
VERONA PULIDO	P4328122 / 100253041 G80



# CARRARA BLANCO NATURAL

Gres Porcellanato Rectificado / Rectified Porcellanato Tiles



## CARRARA BLANCO NATURAL

59,6 cm x 120 cm x 1,1 cm

HIGHKER

P1976818 / 100153703 G369

Butech: Colorstuk Especial n White B24302055 / 100238236



## CARRARA BLANCO NATURAL

59,6 cm x 59,6 cm x 1,1 cm

P1856885 / 100137737 G347

Butech: Colorstuk Especial n White B24302055 / 100238236

# BOTTEGA

Gres Porcellanato / Porcellanato Tiles



## BOTTEGA ACERO

60,2 cm x 60,2 cm x 1,05 cm

P9210751 / 100232694 G333

## BOTTEGA ACERO ANTISLIP

60,2 cm x 60,2 cm x 1,05 cm

P9210849 / 100232695 G333

Butech: Colorstuk Rapid n Gris B21522258/100236834



## BOTTEGA CALIZA

60,2 cm x 60,2 cm x 1,05 cm

P9210752 / 100232656 G333

## BOTTEGA CALIZA ANTISLIP

60,2 cm x 60,2 cm x 1,05 cm

P1990010 / 100264419 G333

Butech: Colorstuk Rapid n Cemento B21522249/100236449

## EMBALAJE / PACKING

MODELO MODEL	PZ/CJ	M2/CJ	*KG/CJ	CJ/PAL	M2/PAL	*KG/PAL	ADHESIVO ADHESIVE BUTECH
59,6 cm x 120 cm	2	1,43	39,14	28	40,05	1095,92	One -flex premium / Super-flex s2
59,6 cm x 59,6 cm	4	1,42	35,24	32	45,47	1127,62	Fr-one n / One-flex Premium
Zócalo 9 cm x 59,6 cm	18	0,97	22,57	56	54,07	1301,92	
HT 31,6 cm x 59,6 cm	2	0,42	11,33	48	11,33	543,84	
HTE 31,6 cm x 59,6 cm	1	0,21	5,67	48	5,67	271,92	

\*valores aproximados. \*approximated values.

## HUELLA TÉCNICA / STEP TILES

MODELO MODEL	31,6 cm x 59,6 cm	ESQUINA DE. / R. CORNER	ESQUINA IZ. / L. CORNER
CARRARA BLANCO NAT.	P9210278 / 100156983 G130	P9210422 / 100193884 G150	P9210409 / 100193834 G150
	31,6 cm x 120 cm G180	G187	G187

## ZÓCALO / SKIRTING BOARDS

MODELO MODEL	9 cm x 59,6 cm
CARRARA BLANCO NAT.	P9210169 / 100138013 G30

## EMBALAJE / PACKING

MODELO MODEL	PZ/CJ	M2/CJ	*KG/CJ	CJ/PAL	M2/PAL	*KG/PAL	ADHESIVO ADHESIVE BUTECH
60,2 cm x 60,2 cm	4	1,45	36,12	32	46,39	1155,97	Fr-one n / One-flex Premium
Zócalo 9 cm x 60,2 cm	18	0,97	23,40	56	54,07	1310,40	

\*valores aproximados. \*approximated values.

## HUELLA TÉCNICA / STEP TILES

MODELO MODEL	31,6 cm x 60,2 cm	ESQUINA DE. / R. CORNER	ESQUINA IZ. / L. CORNER
BOTTEGA ACERO	G130	G150	G150
BOTTEGA CALIZA	G130	G150	G150

## ZÓCALO / SKIRTING BOARDS

MODELO MODEL	9 cm x 60,2 cm
BOTTEGA ACERO	P9210753 / 100243118 G19
BOTTEGA CALIZA	P9210754 / 100243124 G19

# MEAUX

Gres Porcellanato / Porcellanato Tiles



## MEAUX ACERO

60,2 cm x 60,2 cm x 1,05 cm

P9210294 / 100165307 G333

Butech: Colorstuk Rapid n Manhattan B21522248/100236464

# BARI BLANCO

Gres Rectificado / Rectified Tiles



## BARI BLANCO

59,6 cm x 59,6 cm x 1,1 cm

P1856957 / 100155618 G347

Butech: Colorstuk Rapid n Blanco B21522247/100236463

### EMBALAJE / PACKING

MODELO MODEL	PZ/CJ	M2/CJ	*KG/CJ	CJ/PAL	M2/PAL	*KG/PAL	ADHESIVO ADHESIVE BUTECH
60,2 cm x 60,2 cm	4	1,45	36,12	32	46,39	1155,97	Fr-one n / One-flex Premium
Zócalo 9 cm x 60,2 cm	18	0,97	23,40	56	54,07	1310,40	

\*valores aproximados. \*approximated values.

### HUELLA TÉCNICA / STEP TILES



MODELO MODEL	31,6 cm x 60,2 cm	ESQUINA DE. / R. CORNER	ESQUINA IZ. / L. CORNER
MEAUX ACERO	G130	G150	G150

### ZÓCALO / SKIRTING BOARDS



MODELO MODEL	9 cm x 60,2 cm
MEAUX ACERO	P8430144 / 100142846 G19

### EMBALAJE / PACKING

MODELO MODEL	PZ/CJ	M2/CJ	*KG/CJ	CJ/PAL	M2/PAL	*KG/PAL	ADHESIVO ADHESIVE BUTECH
59,6 cm x 59,6 cm	4	1,42	35,04	32	45,47	1121,3	Fr-one n / One-flex Premium
Zócalo 10 cm x 44,6 cm	20	0,87	18,80	68	60,25	1278,40	
HT 31,6 cm x 59,6 cm	2	0,42	11,33	48	19,97	543,84	
HTE 31,6 cm x 59,6 cm	1	0,21	5,67	48	9,98	271,92	

\*valores aproximados. \*approximated values.

### HUELLA TÉCNICA / STEP TILES



MODELO MODEL	31,6 cm x 59,6 cm	ESQUINA DE. / R. CORNER	ESQUINA IZ. / L. CORNER
BARI BLANCO	P9210302 / 100169575 G130	P9210412 / 100193835 G150	P9210406 / 100193845 G150

### ZÓCALO / SKIRTING BOARDS



MODELO MODEL	10 cm x 44,6 cm
BARI BLANCO	P8323609 / 100183950 G7



# CALACATA

Gres Rectificado / Rectified Tiles

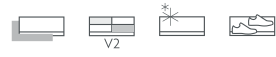

## CALACATA SILVER

59,6 cm x 59,6 cm x 1,1 cm

P1856895 / 100137735 G347

Butech: Colorstuk Rapid n Blanco B21522247/100236463



## CALACATA GOLD

59,6 cm x 59,6 cm x 1,1 cm

P1856898 / 100137734 G347

Butech: Colorstuk Rapid n Blanco B21522247/100236463

# CARRARA BLANCO BRILLO

Gres Rectificado / Rectified Tiles



## CARRARA BLANCO BRILLO

59,6 cm x 59,6 cm x 1,1 cm

P1856896 / 100137736 G347

Butech: Colorstuk Rapid n Blanco B21522247/100236463

## CARRARA BLANCO BRILLO

43,5 cm x 43,5 cm x 1 cm

P1459036 / 100068203 G331

Butech: Colorstuk Rapid n Blanco B21522247/100236463

## EMBALAJE / PACKING

MODELO MODEL	PZ/CJ	M2/CJ	*KG/CJ	CJ/PAL	M2/PAL	*KG/PAL	ADHESIVO ADHESIVE BUTECH
59,6 cm x 59,6 cm	4	1,42	34,81	32	45,47	1081,73	Fr-one n / One-flex Premium
Zócalo 9 cm x 59,6 cm	18	0,97	22,77	56	54,07	1275,12	
HT 31,6 cm x 59,6 cm	2	0,42	11,33	48	19,97	543,84	
HTE 31,6 cm x 59,6 cm	1	0,21	5,67	48	9,98	271,92	

\*valores aproximados. \*approximated values.

## HUELLA TÉCNICA / STEP TILES



MODELO MODEL	31,6 cm x 59,6 cm		ESQUINA DE. / R. CORNER		ESQUINA IZ. / L. CORNER	
CALACATA SILVER	P9210292 / 100162791	G130	P9210421 / 100193891	G150	P9210407 / 100193816	G150
CALACATA GOLD	P9210296 / 100166099	G130	P9210420 / 100193862	G150	P9210411 / 100193846	G150

## ZÓCALO / SKIRTING BOARDS



MODELO MODEL	9 cm x 59,6 cm	
CALACATA SILVER	P9210824 / 100252427	G30
CALACATA GOLD	P9210826 / 100253162	G30

## EMBALAJE / PACKING

MODELO MODEL	PZ/CJ	M2/CJ	*KG/CJ	CJ/PAL	M2/PAL	*KG/PAL	ADHESIVO ADHESIVE BUTECH
59,6 cm x 59,6 cm	4	1,42	31,74	32	45,47	1127,62	Fr-one n / One-flex Premium
43,5 cm x 43,5 cm	5	0,95	20,91	66	62,44	1380	
Zócalo 10 cm x 44,6 cm	20	0,87	18,79	72	60,25	1352,68	
HT 31,6 cm x 59,6 cm	2	0,42	11,33	48	19,97	543,84	
HTE 31,6 cm x 59,6 cm	1	0,21	5,67	48	9,98	271,92	

\*valores aproximados. \*approximated values.

## HUELLA TÉCNICA / STEP TILES



MODELO MODEL	31,6 cm x 59,6 cm		ESQUINA DE. / R. CORNER		ESQUINA IZ. / L. CORNER	
CARRARA BLANCO B.	P9210291 / 100162743	G130	P9210363 / 100190183	G150	P9210364 / 100190152	G150

## ZÓCALO / SKIRTING BOARDS



MODELO MODEL	10 cm x 44,6 cm	
CARRARA BLANCO B.	P4328112 / 100171102	G7

# FONTANA

Gres Rectificado / Rectified Tiles



## FONTANA

59,6 cm x 59,6 cm x 1,1 cm

P1857142 / 100272173 G347

Butech: Colorstuk Rapid n Gris B2152258/100236834

### EMBALAJE / PACKING

MODELO MODEL	PZ/CJ	M2/CJ	*KG/CJ	CJ/PAL	M2/PAL	*KG/PAL	ADHESIVO ADHESIVE BUTECH
59,6 cm x 59,6 cm	4	1,42	37,24	32	45,47	1127,62	Fr-one n / One-flex Premium
Zócalo 9 cm x 59,6 cm	18	0,97	23,25	56	54,07	1301,92	
HT 31,6 cm x 59,6 cm	2	0,42	11,33	48	19,97	543,84	
HTE 31,6 cm x 59,6 cm	1	0,22	5,67	48	9,98	271,92	

\*valores aproximados. \*approximated values.

### HUELLA TÉCNICA / STEP TILES



MODELO MODEL	31,6 cm x 59,6 cm	ESQUINA DE. / R. CORNER	ESQUINA IZ. / L. CORNER
FONTANA	P9210886 / 100274511 G130	P9210887 / 100274504 G150	P9210885 / P92108851 G150

### ZÓCALO / SKIRTING BOARDS



MODELO MODEL	9 cm x 59,6 cm
FONTANA	P9210857 / 100274444 G30

# MILANO

Gres Rectificado / Rectified Tiles

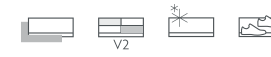

## MILANO TOPO

59,6 cm x 59,6 cm x 1,1 cm

P1857089 / 100228833 G347

Butech: Colorstuk Rapid n Manhattan B21522248/100236464

### EMBALAJE / PACKING

MODELO MODEL	PZ/CJ	M2/CJ	*KG/CJ	CJ/PAL	M2/PAL	*KG/PAL	ADHESIVO ADHESIVE BUTECH
59,6 cm x 59,6 cm	4	1,42	35,06	32	45,47	1122,05	Fr-one n / One-flex Premium
Zócalo 9 cm x 59,6 cm	18	0,97	22,77	56	54,07	1267,69	
HT 31,6 cm x 59,6 cm	2	0,42	12	48	19,97	576	
HTE 31,6 cm x 59,6 cm	1	0,22	6	48	10,54	288	

\*valores aproximados. \*approximated values.

### HUELLA TÉCNICA / STEP TILES



MODELO MODEL	31,6 cm x 59,6 cm	ESQUINA DE. / R. CORNER	ESQUINA IZ. / L. CORNER
MILANO TOPO	P9210663 / 100228928 G130	P9210671 / 100228929 G150	P9210681 / 100228966 G150

### ZÓCALO / SKIRTING BOARDS



MODELO MODEL	9 cm x 59,6 cm
MILANO TOPO	P9210670 / 100228945 G30



# OLIMPO MARFIL

Gres Rectificado / Rectified Tiles

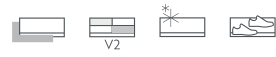

## OLIMPO MARFIL

59,6 cm x 59,6 cm x 1,1 cm

P1856974 / 100161111 G347

Butech: Colorstuk Rapid n Marfil B21522257/100236794

### EMBALAJE / PACKING

MODELO MODEL	PZ/CJ	M2/CJ	*KG/CJ	CJ/PAL	M2/PAL	*KG/PAL	ADHESIVO ADHESIVE BUTECH
59,6 cm x 59,6 cm	4	1,42	35,06	32	45,47	1122,05	Fr-one n / One-flex Premium
Zócalo 9 cm x 59,6 cm	18	0,97	22,77	56	54,07	1275,12	
HT 31,6 cm x 59,6 cm	2	0,42	12	48	19,97	576	
HTE 31,6 cm x 59,6 cm	1	0,22	6	48	10,54	288	

\*valores aproximados. \*approximated values.

### HUELLA TÉCNICA / STEP TILES



MODELO MODEL	31,6 cm x 59,6 cm		ESQUINA DE. / R. CORNER		ESQUINA IZ. / L. CORNER	
OLIMPO MARFIL	P9210356 / 100185671	G130	P9210425 / 100193857	G150	P9210413 / 100193848	G150

### ZÓCALO / SKIRTING BOARDS



MODELO MODEL	9 cm x 59,6 cm	
OLIMPO MARFIL	P9210447 / 100201700	G30

# PERSIA

Gres Rectificado / Rectified Tiles

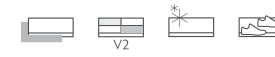

## PERSIA

59,6 cm x 59,6 cm x 1,1 cm

P1856999 / 100179118 G347

Butech: Colorstuk Rapid n Blanco B21522247/100236463

### EMBALAJE / PACKING

MODELO MODEL	PZ/CJ	M2/CJ	*KG/CJ	CJ/PAL	M2/PAL	*KG/PAL	ADHESIVO ADHESIVE BUTECH
59,6 cm x 59,6 cm	4	1,42	35,04	32	45,47	1121,3	Fr-one n / One-flex Premium
Zócalo 9 cm x 59,6 cm	18	0,97	22,64	56	54,07	1266,97	
HT 31,6 cm x 59,6 cm	2	0,42	11,33	48	19,97	543,84	
HTE 31,6 cm x 59,6 cm	1	0,21	5,67	48	9,98	271,92	

\*valores aproximados. \*approximated values.

### HUELLA TÉCNICA / STEP TILES



MODELO MODEL	31,6 cm x 59,6 cm		ESQUINA DE. / R. CORNER		ESQUINA IZ. / L. CORNER	
PERSIA	P9210434 / 100193853	G130	P9210440 / 100193949	G150	P9210437 / 100193849	G150

### ZÓCALO / SKIRTING BOARDS



MODELO MODEL	9 cm x 59,6 cm	
PERSIA	P9210839 / 100264279	G30

## RECIFE GRIS

Gres Rectificado / Rectified Tiles



### RECIFE GRIS

43,5 cm x 43,5 cm x 1 cm

P1459084 / 100093301 G331

Butech: Colorstuk Rapid n Gris B21522258/100236834

### EMBALAJE / PACKING

MODELO MODEL	PZ/CJ	M2/CJ	*KG/CJ	CJ/PAL	M2/PAL	*KG/PAL	ADHESIVO ADHESIVE BUTECH
43,5 cm x 43,5 cm	5	0,95	20,91	66	62,44	1380	Fr-one n / One-flex Premium

\*valores aproximados. \*approximated values.

## SENA

Gres Rectificado / Rectified Tiles



### SENA ACERO

59,6 cm x 59,6 cm x 1,03 cm

P1857085 / 100228827 G347

Butech: Colorstuk Rapid n Manhattan B21522248/100236464



### SENA CALIZA

59,6 cm x 59,6 cm x 1,03 cm

P1857084 / 100228841 G347

Butech: Colorstuk Rapid n Gris B21522258/100236834

### EMBALAJE / PACKING

MODELO MODEL	PZ/CJ	M2/CJ	*KG/CJ	CJ/PAL	M2/PAL	*KG/PAL	ADHESIVO ADHESIVE BUTECH
59,6 cm x 59,6 cm	4	1,42	35,06	32	45,47	1122,05	Fr-one n / One-flex Premium
Zócalo 9 cm x 59,6 cm	18	0,97	22,77	56	54,07	1275,12	
HT 31,6 cm x 59,6 cm	2	0,42	12	48	19,97	576	
HTE 31,6 cm x 59,6 cm	1	0,21	6	48	10,54	288	

\*valores aproximados. \*approximated values.

### HUELLA TÉCNICA / STEP TILES

MODELO MODEL	31,6 cm x 59,6 cm		ESQUINA DE. / R. CORNER		ESQUINA IZ. / L. CORNER	
SENA ACERO	P9210665 / 100228936	G130	P9210679 / 100228972	G150	P9210669 / 100228946	G150
SENA CALIZA	P9210664 / 100228944	G130	P9210680 / 100228980	G150	P9210676 / 100228947	G150

### ZÓCALO / SKIRTING BOARDS

MODELO MODEL	9 cm x 59,6 cm	
SENA ACERO	P9210659 / 100228937	G30
SENA CALIZA	P9210658 / 100228938	G30



# THASSOS

Gres Rectificado / Rectified Tiles

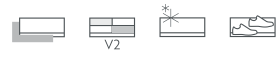

## THASSOS

59,6 cm x 59,6 cm x 1,03 cm

P1857086 / 100228794 G347

Butech: Colorstuk Especial n White B24302055 / 100238236

### EMBALAJE / PACKING

MODELO MODEL	PZ/CJ	M2/CJ	*KG/CJ	CJ/PAL	M2/PAL	*KG/PAL	ADHESIVO ADHESIVE BUTECH
59,6 cm x 59,6 cm	4	1,42	35,06	32	45,47	1122,05	Fr-one n / One-flex Premium
Zócalo 9 cm x 59,6 cm	18	0,97	22,77	56	54,07	1275,12	
HT 31,6 cm x 59,6 cm	2	0,42	12	48	19,97	576	
HTE 31,6 cm x 59,6 cm	1	0,22	6	48	10,54	288	

\*valores aproximados. \*approximated values.

### HUELLA TÉCNICA / STEP TILES



MODELO MODEL	31,6 cm x 59,6 cm		ESQUINA DE. / R. CORNER		ESQUINA IZ. / L. CORNER	
THASSOS	P9210675 / 100228965	G130	P9210673 / 100228990	G150	P9210674 / 100228935	G150

### ZÓCALO / SKIRTING BOARDS



MODELO MODEL	9 cm x 59,6 cm	
THASSOS	P9210678 / 100228971	G30

# TRAVERTINO MEDICI

Gres Rectificado / Rectified Tiles



## TRAVERTINO MEDICI

59,6 cm x 59,6 cm x 1,03 cm

P1857033 / 100191337 G347

Butech: Colorstuk Rapid n Beige B21522252/100236808

### EMBALAJE / PACKING

MODELO MODEL	PZ/CJ	M2/CJ	*KG/CJ	CJ/PAL	M2/PAL	*KG/PAL	ADHESIVO ADHESIVE BUTECH
59,6 cm x 59,6 cm	4	1,42	35,06	32	45,47	1122,05	Fr-one n / One-flex Premium
Zócalo 9 cm x 59,6 cm	18	0,97	22,77	56	54,07	1275,12	
HT 31,6 cm x 59,6 cm	2	0,42	12	48	19,97	576	
HTE 31,6 cm x 59,6 cm	1	0,22	6	48	10,54	288	

\*valores aproximados. \*approximated values.

### HUELLA TÉCNICA / STEP TILES



MODELO MODEL	31,6 cm x 59,6 cm		ESQUINA DE. / R. CORNER		ESQUINA IZ. / L. CORNER	
TRAVERTINO MEDICI	P9210430 / 100193860	G130	P9210441 / 100193824	G150	P9210439 / 100193873	G150

### ZÓCALO / SKIRTING BOARDS



MODELO MODEL	9 cm x 59,6 cm	
TRAVERTINO MEDICI	P9210668 / 100228939	G30

# MARMI BLANCO

Gres Rectificado / Rectified Tiles

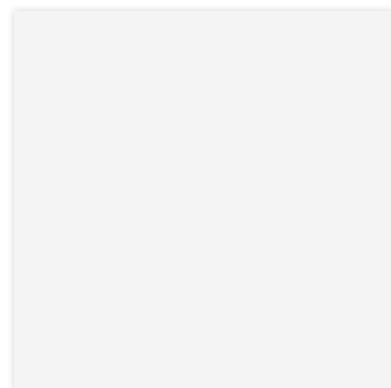

## MARMI BLANCO

59,6 cm x 59,6 cm x 1,1 cm

P1856893 / 100137752 G347

Butech: Colorstuk Rapid n Blanco B21522247/100236463

## EMBALAJE / PACKING

MODELO MODEL	PZ/CJ	M2/CJ	*KG/CJ	CJ/PAL	M2/PAL	*KG/PAL	ADHESIVO ADHESIVE BUTECH
59,6 cm x 59,6 cm	4	1,42	34,81	32	45,47	1081,73	Fr-one n / One-flex Premium
Zócalo 9 cm x 59,6 cm	18	0,97	22,77	56	54,07	1275,12	
HT 31,6 cm x 59,6 cm	2	0,42	11,33	48	19,97	543,84	
HTE 31,6 cm x 59,6 cm	1	0,21	5,67	48	9,98	271,92	

\*valores aproximados. \*approximated values.

## HUELLA TÉCNICA / STEP TILES



MODELO MODEL	31,6 cm x 59,6 cm	ESQUINA DE. / R. CORNER	ESQUINA IZ. / L. CORNER
MARMI BLANCO	P9210303 / 100169714 G130	P9210424 / 100193892 G150	P9210410 / 100193817 G150

## ZÓCALO / SKIRTING BOARDS



MODELO MODEL	9 cm x 59,6 cm
MARMI BLANCO	P9210825 / 100253182 G30

# BOTTEGA

Gres Porcellanato / Porcellanato Tiles



## BOTTEGA ACERO

44,3 cm x 44,3 cm x 1 cm

P2460080 / 100225055 G311

## BOTTEGA ACERO C-2

P2460088 / 100242386 G311

## BOTTEGA ACERO ANTISLIP

P2460082 / 100236432 G311

Butech: Colorstuk Rapid n Cemento B21522249/100236449



## BOTTEGA CALIZA

44,3 cm x 44,3 cm x 1 cm

P2460079 / 100225065 G311

## BOTTEGA CALIZA C-2

P2460087 / 100242410 G311

## BOTTEGA CALIZA ANTISLIP

P2460083 / 100236404 G311

Butech: Colorstuk Rapid n Gris B21522258/100236834

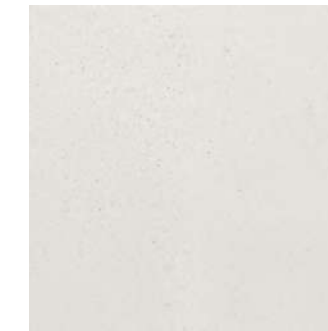

## BOTTEGA WHITE

44,3 cm x 44,3 cm x 1 cm

P2460086 / 100242728 G311

Butech: Colorstuk Rapid n Gris B21522258/100236834

## EMBALAJE / PACKING

MODELO MODEL	PZ/CJ	M2/CJ	*KG/CJ	CJ/PAL	M2/PAL	*KG/PAL	ADHESIVO ADHESIVE BUTECH
44,3 cm x 44,3 cm	5	0,98	21,79	66	64,76	1438,14	Fr-one n / One-flex Premium
Zócalo 10 cm x 44,3 cm	20	0,89	18,32	68	60,25	1245,76	

\*valores aproximados. \*approximated values.

## HUELLA TÉCNICA / STEP TILES



MODELO MODEL	31,6 cm x 118,7 cm	ESQUINA DE. / R. CORNER	ESQUINA IZ. / L. CORNER
BOTTEGA	G125	G138	G138

## ZÓCALO / SKIRTING BOARDS



MODELO MODEL	10 cm x 44,3 cm
BOTTEGA ACERO	P8270090 / 100243138 G7
BOTTEGA CALIZA	P8270091 / 100243165 G7
BOTTEGA WHITE	P8270092 / 100243208 G7



## DOVER

Gres Porcellanato / Porcellanato Tiles



### DOVER ACERO

44,3 cm x 44,3 cm x 1 cm

P2460065 / 100157354 G311

*Butech: Colorstuk Rapid n Manhattan B21522248/100236464*



### DOVER CALIZA

44,3 cm x 44,3 cm x 1 cm

P2460064 / 100157357 G311

*Butech: Colorstuk Rapid n Gris B21522258/100236834*

## NANTES

Gres Porcellanato / Porcellanato Tiles



### NANTES ACERO

44,3 cm x 44,3 cm x 1 cm

P24601031 / 100273348 G311

*Butech: Colorstuk Rapid n Gris B21522258/100236834*



### NANTES CALIZA

44,3 cm x 44,3 cm x 1 cm

P24601021 / 100273420 G311

*Butech: Colorstuk Rapid n Gris B21522258/100236834*

### EMBALAJE / PACKING

MODELO MODEL	PZ/CJ	M2/CJ	*KG/CJ	CJ/PAL	M2/PAL	*KG/PAL	ADHESIVO ADHESIVE BUTECH
44,3 cm x 44,3 cm	5	0,98	22,65	66	64,76	1494	Fr-one n / One-flex Premium
Zócalo 10 cm x 44,3 cm	20	0,89	18,80	68	60,25	1278,40	

\*valores aproximados. \*approximated values.

### HUELLA TÉCNICA / STEP TILES

MODELO MODEL	31,6 cm x 59,6 cm	ESQUINA DE. / R. CORNER	ESQUINA IZ. / L. CORNER
DOVER	G125	G138	G138

### ZÓCALO / SKIRTING BOARDS

MODELO MODEL	10 cm x 44,3 cm
DOVER ACERO	P8035368 / 100159645 G7
DOVER CALIZA	P8035367 / 100159646 G7

### EMBALAJE / PACKING

MODELO MODEL	PZ/CJ	M2/CJ	*KG/CJ	CJ/PAL	M2/PAL	*KG/PAL	ADHESIVO ADHESIVE BUTECH
44,3 cm x 44,3 cm	5	0,98	22,65	66	64,76	1494	Fr-one n / One-flex Premium
Zócalo 10 cm x 44,3 cm	20	0,89	18,80	68	60,25	1278,40	

\*valores aproximados. \*approximated values.

### HUELLA TÉCNICA / STEP TILES

MODELO MODEL	31,6 cm x 59,6 cm	ESQUINA DE. / R. CORNER	ESQUINA IZ. / L. CORNER
NANTES	G125	G138	G138

### ZÓCALO / SKIRTING BOARDS

MODELO MODEL	10 cm x 44,3 cm
NANTES ACERO	P8270101 / 100273416 G7
NANTES CALIZA	P8270094 / 100273328 G7

NEW

# NAST

Gres Porcellanato / Porcellanato Tiles



**NAST ARENA**  
44,3 cm x 44,3 cm x 1 cm  
P2460104 / 100273491 G311  
*Butech: Colorstuk Rapid n Beige B21522252/100236808*



**NAST BLANCO**  
44,3 cm x 44,3 cm x 1 cm  
P2460106 / 100273484 G311  
*Butech: Colorstuk Rapid n Marfil B21522257/100236794*



**NAST BROWN**  
44,3 cm x 44,3 cm x 1 cm  
P2460108 / 100273465 G311  
*Butech: Colorstuk Rapid n Beech B21522232/100204254*



**NAST CALIZA**  
44,3 cm x 44,3 cm x 1 cm  
P2460100 / 100272366 G311  
*Butech: Colorstuk Rapid n Beige B21522252/100236808*



**NAST DARK**  
44,3 cm x 44,3 cm x 1 cm  
P2460109 / 100273466 G311  
*Butech: Colorstuk Rapid n Cemento B21522249/100236449*

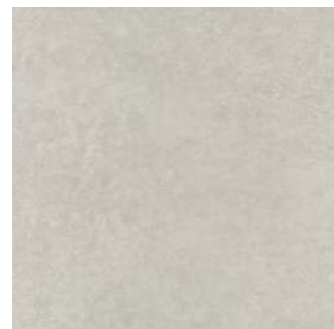

**NAST GREY**  
44,3 cm x 44,3 cm x 1 cm  
P2460105 / 100273493 G311  
*Butech: Colorstuk Rapid n Gris B21522258/100236834*

## EMBALAJE / PACKING

MODELO MODEL	PZ/CJ	M2/CJ	*KG/CJ	CJ/PAL	M2/PAL	*KG/PAL	ADHESIVO ADHESIVE BUTECH
44,3 cm x 44,3 cm	5	0,98	22,65	66	64,76	1494	Fr-one n / One-flex Premium
Zócalo 10 cm x 44,3 cm	20	0,89	18,80	68	60,25	1278,40	

\*valores aproximados. \*approximated values.

## HUELLA TÉCNICA / STEP TILES

MODELO MODEL	31,6 cm x 59,6 cm	ESQUINA DE. / R. CORNER	ESQUINA IZ. / L. CORNER
NAST	G125	G138	G138

## ZÓCALO / SKIRTING BOARDS

MODELO MODEL	10 cm x 44,3 cm
NAST ARENA	P8270095 / 100273590 G7
NAST BLANCO	P8270102 / 100273565 G7
NAST BROWN	P8270097 / 100273583 G7
NAST CALIZA	P8270099 / 100273538 G7
NAST DARK	P8270103 / 100273574 G7
NAST GREY	P8270098 / 100273592 G7
	P8270102 / 100273565 G7

# NIMBUS

Gres Porcellanato / Porcellanato Tiles



**NIMBUS BLANCO**  
44,3 cm x 44,3 cm x 1 cm  
P2460107 / 100273467 G311  
*Butech: Colorstuk Rapid n Blanco B21522247/100236463*



**NIMBUS SILVER**  
44,3 cm x 44,3 cm x 1 cm  
P2460101 / 100273482 G311  
*Butech: Colorstuk Rapid n Antracita B21522250/100236481*

## EMBALAJE / PACKING

MODELO MODEL	PZ/CJ	M2/CJ	*KG/CJ	CJ/PAL	M2/PAL	*KG/PAL	ADHESIVO ADHESIVE BUTECH
44,3 cm x 44,3 cm	5	0,98	22,65	66	64,76	1494	Fr-one n / One-flex Premium
Zócalo 10 cm x 44,3 cm	20	0,89	18,80	68	60,25	1278,40	

\*valores aproximados. \*approximated values.

## HUELLA TÉCNICA / STEP TILES

MODELO MODEL	31,6 cm x 59,6 cm	ESQUINA DE. / R. CORNER	ESQUINA IZ. / L. CORNER
NIMBUS	G125	G138	G138

## ZÓCALO / SKIRTING BOARDS

MODELO MODEL	10 cm x 44,3 cm
NIMBUS BLANCO	P8270096 / 100273584 G7
NIMBUS SILVER	P8270100 / 100273585 G7



## PARK

Gres Porcellanato / Porcellanato Tiles



### PARK BLANCO

44,3 cm x 44,3 cm x 1 cm

P2460075 / 100219091 G311

Butech: Colorstuk Rapid n Gris B21522258/100236834



### PARK GRIS

44,3 cm x 44,3 cm x 1 cm

P2460068 / 100157370 G311

Butech: Colorstuk Rapid n Manhattan B21522248/100236464

### EMBALAJE / PACKING

MODELO MODEL	PZ/CJ	M2/CJ	*KG/CJ	CJ/PAL	M2/PAL	*KG/PAL	ADHESIVO ADHESIVE BUTECH
44,3 cm x 44,3 cm	5	0,98	22,65	66	64,76	1494	Fr-one n / One-flex Premium
Zócalo 10 cm x 44,3 cm	20	0,89	18,80	68	60,25	1278,40	

\*valores aproximados. \*approximated values.

### HUELLA TÉCNICA / STEP TILES



MODELO MODEL	31,6 cm x 59,6 cm	ESQUINA DE. / R. CORNER	ESQUINA IZ. / L. CORNER
PARK	G125	G138	G138

### ZÓCALO / SKIRTING BOARDS



MODELO MODEL	10 cm x 44,3 cm
PARK BLANCO	P8270080 / 100219158 G7
PARK GRIS	P8270069 / 100158749 G7

## RODANO

Gres Porcellanato / Porcellanato Tiles



### RODANO ACERO

44,3 cm x 44,3 cm x 1 cm

P2460033 / 100123817 G311

Butech: Colorstuk Rapid n Manhattan B21522248/100236464



### RODANO GALIZA

44,3 cm x 44,3 cm x 1 cm

P2460034 / 100123818 G311

Butech: Colorstuk Rapid n Gris B21522258/100236834



### RODANO TAUPE

44,3 cm x 44,3 cm x 1 cm

P2460032 / 100123819 G311

Butech: Colorstuk Rapid n Cemento B21522249/100236449

### EMBALAJE / PACKING

MODELO MODEL	PZ/CJ	M2/CJ	*KG/CJ	CJ/PAL	M2/PAL	*KG/PAL	ADHESIVO ADHESIVE BUTECH
44,3 cm x 44,3 cm	5	0,98	22,65	66	64,76	1494	Fr-one n / One-flex Premium
Zócalo 10 cm x 44,3 cm	20	0,89	18,80	68	60,25	1278,40	

\*valores aproximados. \*approximated values.

### HUELLA TÉCNICA / STEP TILES



MODELO MODEL	31,6 cm x 59,6 cm	ESQUINA DE. / R. CORNER	ESQUINA IZ. / L. CORNER
RODANO	G125	G138	G138

### ZÓCALO / SKIRTING BOARDS



MODELO MODEL	10 cm x 44,3 cm
RODANO ACERO	P8270053 / 100141845 G7
RODANO CALIZA	P8270046 / 100130259 G7
RODANO TAUPE	P8270054 / 100141846 G7

# CARRARA BLANCO BRILLO

Tierra Neutra · Gres No Rectificado / Non Coloured Biscuit · Non Rectified Gres



## CARRARA BLANCO BRILLO

44,6 cm x 44,6 cm x 1 cm

P2460042 /100140439 G319

Butech: Colorstuk Rapid n Blanco B21522247/100236463

### EMBALAJE / PACKING

MODELO MODEL	PZ/CJ	M2/CJ	*KG/CJ	CJ/PAL	M2/PAL	*KG/PAL	ADHESIVO ADHESIVE BUTECH
44,6 cm x 44,6 cm	5	0,98	22,65	66	64,76	1494	Fr-one n / One-flex Premium
Zócalo 10 cm x 44,3 cm	20	0,89	18,80	68	60,25	1278,40	

\*valores aproximados. \*approximated values.

### HUELLA TÉCNICA / STEP TILES



MODELO MODEL	31,6 cm x 59,6 cm	ESQUINA DE. / R. CORNER	ESQUINA IZ. / L. CORNER
CARRARA BLANCO B.	G125	G138	G138

### ZÓCALO / SKIRTING BOARDS



MODELO MODEL	10 cm x 44,6 cm
CARRARA BLANCO B.	P4328112 / 100171102 G7

# FONTANA MATT

Gres Porcellanato / Porcellanato Tiles



## FONTANA MATT

44,3 cm x 44,3 cm x 1 cm

P2460111 /100272974 G311

Butech: Colorstuk Rapid n Gris B21522258/100236834

### EMBALAJE / PACKING

MODELO MODEL	PZ/CJ	M2/CJ	*KG/CJ	CJ/PAL	M2/PAL	*KG/PAL	ADHESIVO ADHESIVE BUTECH
44,3 cm x 44,3 cm	5	0,98	22,65	66	64,76	1494	Fr-one n / One-flex Premium

\*valores aproximados. \*approximated values.

### HUELLA TÉCNICA / STEP TILES



MODELO MODEL	31,6 cm x 59,6 cm	ESQUINA DE. / R. CORNER	ESQUINA IZ. / L. CORNER
FONTANA MATT	G125	G138	G138

NEW



# NOVA

Gres Porcellanato / Porcellanato Tiles

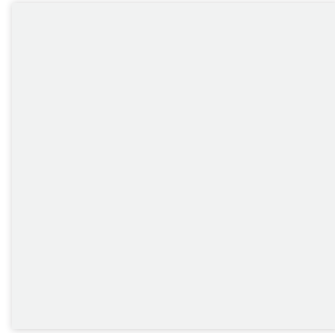

## NOVA

44,3 cm x 44,3 cm x 1 cm

P2460110 / 100271019 G311

*Butech: Colorstuk Rapid n Blanco B21522247/100236463*

## NEW

# JAPAN

Gres Porcellanato / Porcellanato Tiles



## JAPAN BLANCO

44,3 cm x 44,3 cm x 1 cm

P2460048 / 100140546 G311

*Butech: Colorstuk Rapid n Gris B21522258/100236834*

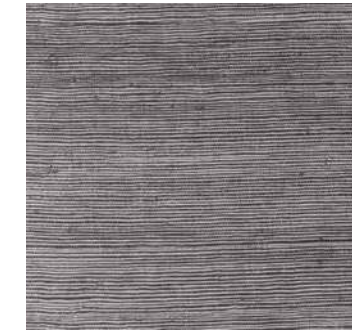

## JAPAN MARINE

44,3 cm x 44,3 cm x 1 cm

P2460049 / 100140547 G311

*Butech: Colorstuk Rapid n Cemento B21522249/100236449*

### EMBALAJE / PACKING

MODELO MODEL	PZ/CJ	M2/CJ	*KG/CJ	CJ/PAL	M2/PAL	*KG/PAL	ADHESIVO ADHESIVE BUTECH
44,3 cm x 44,3 cm	5	0,98	22,65	66	64,76	1494	Fr-one n / One-flex Premium

\*valores aproximados. \*approximated values.

### EMBALAJE / PACKING

MODELO MODEL	PZ/CJ	M2/CJ	*KG/CJ	CJ/PAL	M2/PAL	*KG/PAL	ADHESIVO ADHESIVE BUTECH
44,3 cm x 44,3 cm	5	0,98	22,65	66	64,76	1494	Fr-one n / One-flex Premium

\*valores aproximados. \*approximated values.

# NO

Nuestro catálogo - Definición de iconos - Instrucciones de colocación - Información técnica - Tiendas y Asociados.

## **GUÍA TÉCNICA**

*Our catalogue - Icon definition  
- Installation instructions  
- Certifications - Technical  
information - Distributors &  
Stores.*

## **TECH- NICAL GUIDE**





## NUESTRO CATÁLOGO / OUR CATALOGUE

Para ayudar a entender nuestro catálogo, nos hemos comprometido a desglosar cada uno de los datos que aparecen. De este modo, queremos que su utilización sea mucho más práctica y como no, funcional.

*In order to understand our catalogue an explanation of the data which appears in it is necessary. This explanation will make the use of our catalogue more practical and of course useful.*

The screenshot shows a product catalog page for 'ANTIQUE' tiles. Key elements highlighted include:

- Série / Serie:** Located at the top left of the page.
- Página / Page:** Located below the series name.
- Descripción de producto / Product description:** A box pointing to the 'ANTIQUE' product name and its description.
- Grupo de precios / Price Group:** A box pointing to the 'ANTIQUE' product name.
- Tipología de producto / Type of product:** A box pointing to the 'ANTIQUE' product name.
- Color de junta / Joint colour:** A box pointing to the 'ANTIQUE BLACK' and 'ANTIQUE BLUER' color swatches.
- Datos técnicos / Technical Data:** A box pointing to the technical specifications table at the bottom of the product listing.
- Embalaje de Producto / Product Packing:** A box pointing to the 'EMBALAJE / PACKING' table.
- HUALLA TÉCNICA / STEP TILES:** A box pointing to the technical drawing of a step tile.
- ZÓCALO / SKirting BOARDS:** A box pointing to the skirting board product image.
- Código / Code:** A box pointing to the 'ANTIQUE' product name.

Bajo el nombre del producto aparecen dos códigos. El código KEA, y el código SAP. *Underneath the name of the product two codes appear. The kea code system and the SAP code system.*

**Embalaje de Producto / Product Packing**

En cada pié de página se detalla datos de embalaje de los productos que aparecen, tales como: nº piezas por caja, m2 por caja, peso de caja, peso del pallet... *On each footnote the packaging information appears for the material displayed on th page. Number of pieces per box, sqm per box, per pal, weight...*

**Color de junta / Joint colour**

Color de junta recomendado por Butech. *Joint color recommended by Butech*

**Datos técnicos / Technical Data**

Los modelos vienen acompañados por una serie de iconos, los cuales nos indican datos técnicos de cada modelo. *Models are presented with a set of icons which give information about the technical characteristics of each product.*

**Despiece / Piece**



## DEFINICIÓN DE ICONOS / ICON DEFINITION



**BRILLANTE:** Acabado brillante con un alto grado de reflexión a la luz. *GLOSS: Shiny surface finish with a high degree of light reflection.*



**MATE:** Acabado superficial de aspecto natural, no brillante. *MATT: Natural, not shiny, surface finish.*



**DIRECCIONALIDAD:** Observar la parte trasera de las piezas para su correcta colocación. Colocar las piezas de forma que las flechas apunten siempre hacia arriba. *DIRECTIONALITY: Please have a look the at the back side of the tile for a proper installation. Arrows should point. Up when fixing the tiles.*



**RECTIFICADO:** Nombre que recibe el acabado de aquellas baldosas mejoradas dimensionalmente tras el proceso de cocción. El mecanizado al que se somete realiza igualmente la calidad estética del ambiente formado. *RECTIFIED: Name given to the finish of tiles dimensionally after firing. The process enhances the aesthetic quality of the setting created.*



**PORCELÁNICO TÉCNICO:** Baldosa con un alto grado de compactación, uniforme en aspecto desde el soporte cerámico hasta la decoración y un menor porcentaje de vidriado en la composición respecto a las baldosas convencionales. *TECHNIC PORCELLANIC: Tile with a high degree of compaction, uniform in appearance in the ceramic base as well as in the decoration on top and a lower percentage of glaze in the composition compared to conventional tiles.*



**RELIEVE:** Acabado con resaltes importantes claramente definidos y que aportan sensación de volumen a la superficie. *RELIEF: Finish with high and clearly defined ridges, providing volume to the surface.*



**TEXTURADO:** Superficie con pequeños resaltes que proporcionan un acabado con relieve suave. *TEXTURED FINISH: Surface with small protrusions that provide a smooth relief finish.*



**TEXTURADO:** Acabado brillante conseguido a través del mecanizado superficial de la etapa de cocción. *TEXTURED FINISH: The surface brightness is achieved during the firing process in the kiln.*



**METALIZADO:** Acabado superficial que reproduce el aspecto que presentan las superficies metálicas brillantes. *NON SLIP: A finish that reproduces shiny metal surface.*



**LUSTRE BRILLO:** Aplicación superficial que dota de alto brillo a una parte o a la totalidad de la decoración de la baldosa, con el fin de remarcar zonas de relieve, dibujos o formas del diseño de la pieza. *GLOSS LUSTER: An application applied to the surface which either brings out part or all of the high gloss in the decoration so that the relief, the pattern or the design of the tile is highlighted.*



**LUSTRE:** Aplicación superficial que dota de brillo a una parte o a la totalidad de la decoración de la baldosa, con el fin de remarcar zonas de relieve, dibujos o formas del diseño de la pieza. *LUSTER: An application applied to the surface which either brings out part or all of the high gloss in the decoration so that the relief, the pattern or the design of the tile is highlighted.*



**LAPADO:** Las baldosas son pulimentadas mecánicamente de forma heterogénea, creando un efecto de mate-brillo muy natural, similar al que se produce en las superficies que tienen un uso continuado en el tiempo. *LAPPATO: The tiles are polished mechanically and unevenly, creating a very natural matt-gloss effect, similar to that seen on surfaces that have become worn over time.*



**PAV. / REV. COMBINABLE:** Avisa que las series disponen de revestimiento o pavimento combinable. *WT / FT MATCHING AVAILABLE: Informes that the series have matching floor or wall tiles available.*



**NECESITA REJUNTADO:** Los modelos identificados con este símbolo, preferentemente mosaicos y complementos, precisan ser rejuntados en toda su superficie. *IT NEEDS TO BE GROUTED: Models with this symbol (mainly mosaics and complementary tile pieces) need to be grouted across the whole surface.*



**STEX / RAF:** Cerámica válida para suelos técnicos de exterior. *STEX / RAF: Ceramics valid for outdoor technical floors.*



**ANTISLIP:** Textura superficial que minimiza el riesgo al deslizamiento. Acabados suaves que aportan seguridad al caminar. *NON SLIP: Surface texture which minimises the risk of slippage. Smooth finishes that guarantee safe steps.*



**TRANSITO PEATONAL:** Divididos en tres niveles: Ligero, Medio e Intenso. *PEDESTRIAN TRAFFIC: Divided in three levels: Slight, Moderate and Hard.*



**DESTONIFICADO:** Las series identificadas con este icono presentan un diseño general destonificado que puede requerir la conformación de paneles lo suficientemente representativos en número de piezas, como para poder apreciar el grado de variación tonal y de aspecto. V1: Uniforme, V2: Ligero, V3: Moderado, V4: Aleatorio. *TONE VARIATIONS: Series marked with this icon have a high degree of shade variation. As a result, a board with a tiled surface might be needed to reflect true appearance and shade variation once laid. V1: Uniform, V2: Light, V3: Moderate, V4: Random.*

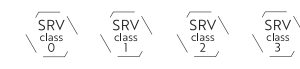

Clasificación de los suelos según su resbalabilidad. *Rating system for flooring depending on its slip resistance.*



**GRANILLA TECNICA:** Aplicación superficial previa de granillas específicas para la serie STON-KER, aplicadas con anterioridad a la cocción y que genera una superficie antideslizante con buena resistencia al desgaste. *TECHNICAL GRAIN: Previous surface application of specific granules for the STON-KER series which is applied prior to the firing process generating a non-slip surface with a optimal wear resistance.*



**RESISTENCIA AL DESLIZAMIENTO:** Describe el método para determinar la resistencia al deslizamiento en suelos usados en sitios donde la gente caminará descalza. *SLIP RESISTENCE: It describes the method for determining the slip properties of floors used in places where people will be walking barefoot.*

R9 Fricción estática baja. R9 Low static friction. R10 Fricción estática normal. R10 Normal static friction. R11 Fricción estática incrementable. R11 Increased static friction. R12 Fricción estática alta. R12 High static friction. R13 Fricción estática muy alta. R13 Very high static friction.



Coeficiente dinámico de fricción. (Mercado USA y Francés). *Dynañic Coefficient Of Friction. (USA and french market).*



## GRUPOS DE VENTA FACHADAS / FACADE PRICE GROUP

FORMATO SIZE		FORMATO SIZE	
43,5x65,9 rn4	G415	45x90 rn4	G432
43,5x65,9 mll	G435	45x90 mll	G458
43,5x65,9 mll + rn4	G446	45x90 mll + rn4	G473
59,6x59,6 rn4	G420	19,3x120 rn4 / 19,3xmll	G483
59,6x59,6 mll	G440	19,3x120 rn6	G490
59,6x59,6 mll+rn4	G455	19,3x120 mll + rn6	G494
59,6x120 rn4	G462		
59,6x120 rn6	G467		
59,6x120 mll / 80x80 mll	G479		
59,6x120 mll + rn4 ver	G484		
59,6x120 mll + rn6 hor	G488		

## INFORMACIÓN SOBRE LA ILUMINACIÓN / LIGHT INFORMATION

El tipo de luz existente en el espacio a revestir resulta fundamental para conseguir la continuidad del tono entre suelo y pared, por lo que se recomienda la utilización de luz blanca, la misma que se emplea en el proceso de igualación realizado en Porcelanosa.

*Considering the existing light in a room is essential to achieve continuity between the tone of the wall and the floor. This is why white light is recommended, which is the same one that Porcelanosa applies in its levelling process.*



Luz fría  
Cold light

Luz blanca  
Neutral light

Luz cálida  
Warm light



## CERTIFICADOS / CERTIFICATES



### ECOLABEL

LA ETIQUETA ECOLÓGICA EUROPEA, ES UN ESQUEMA VOLUNTARIO DE CERTIFICACIÓN AMBIENTAL QUE PRETENDE DISTINGUIR AQUELLOS PRODUCTOS DE MERCADO Y SERVICIOS QUE SON RESPETUOSOS CON EL MEDIO AMBIENTE. CREADO EN 1992, LOS PRODUCTOS Y SERVICIOS CERTIFICADOS CON LA ECOLABEL, LLEVAN CONSIGO EL LOGO DE LA FLOR PERMITIENDO SU IDENTIFICACIÓN CLARA Y FÁCIL A LOS CONSUMIDORES Y COMPRADORES, TANTO PÚBLICOS COMO PRIVADOS. A PESAR DE QUE EL LOGO PUEDE PARECER SIMPLE, LOS CRITERIOS AMBIENTALES QUE HAY DETRÁS DE LA CERTIFICACIÓN SON CONSISTENTES Y SÓLO LOS MEJORES PRODUCTOS, LOS MÁS RESPETUOSOS CON EL MEDIO AMBIENTE, SON CERTIFICADOS CON EL CARACTERÍSTICO DISTINTIVO DE LA FLOR. LA SERIE STONKER ECOLOGIC, CUENTA CON DICHO DISTINTIVO.

*THE EUROPEAN ECOLABEL IS A VOLUNTARY SCHEME FOR ENVIRONMENTAL CERTIFICATION, DESIGNED TO DISTINGUISH PRODUCTS AND SERVICES THAT ARE ENVIRONMENTALLY-FRIENDLY. CREATED IN 1992, THE PRODUCTS AND SERVICES AWARDED THE ECOLABEL CARRY THE FLOWER LOGO, ALLOWING CONSUMERS – INCLUDING PUBLIC AND PRIVATE PURCHASERS – TO IDENTIFY THEM EASILY. WHILE THE LOGO MAY BE SIMPLE, THE ENVIRONMENTAL CRITERIA BEHIND IT ARE TOUGH, AND ONLY THE VERY BEST PRODUCTS, WHICH ARE KINDEST TO THE ENVIRONMENT, ARE ENTITLED TO CARRY THE EU ECOLABEL. THE STONKER ECOLOGIC SERIES CARRIES THIS LABEL.*



### HUELLA CARBONO / CARBON FOOTPRINT

STONKER ECOLOGIC CUENTA TAMBIÉN CON UN ESTUDIO DE HUELLA DE CARBONO (CARBON FOOTPRINT) Y LA CERTIFICACIÓN POSTERIOR POR AENOR SEGÚN REQUISITOS DEL REFERENCIAL BRITÁNICO PAS 2050 (CRADLE TO GATE). LOS OBJETIVOS DEL ESTUDIO REALIZADO SON DETERMINAR LA CONTRIBUCIÓN "CUANTIFICADA" DEL PROCESO DE FABRICACIÓN Y DISTRIBUCIÓN DE ESTE PRODUCTO AL CAMBIO CLIMÁTICO, IDENTIFICAR POSIBLES REDUCCIONES DE EMISIONES DE GASES DE EFECTO INVERNADERO Y AMPLIAR LA INFORMACIÓN PARA INCORPORAR EL IMPACTO DE LAS EMISIONES EN LAS DECISIONES SOBRE PROVEEDORES, MATERIALES, DISEÑO DE PRODUCTO, PROCESOS DE FABRICACIÓN, ETC.

*A CARBON FOOTPRINT STUDY HAS ALSO BEEN CARRIED OUT FOR STONKER ECOLOGIC, WITH SUBSEQUENT CERTIFICATION BY AENOR ACCORDING TO THE BRITISH PAS 2050 'CRADLE TO GATE' ASSESSMENT. THE AIMS OF THE STUDY ARE TO DETERMINE THE 'QUANTIFIED' CONTRIBUTION OF THE MANUFACTURING AND DISTRIBUTION PROCESS FOR THIS PRODUCT TO CLIMATE CHANGE, TO IDENTIFY POSSIBLE WAYS OF REDUCING GREENHOUSE GAS EMISSIONS, AND TO EXTEND THE INFORMATION TO INCLUDE THE IMPACT OF EMISSIONS IN DECISIONS MADE REGARDING SUPPLIERS, MATERIALS, PRODUCT DESIGN, MANUFACTURING PROCESSES, ETC.*

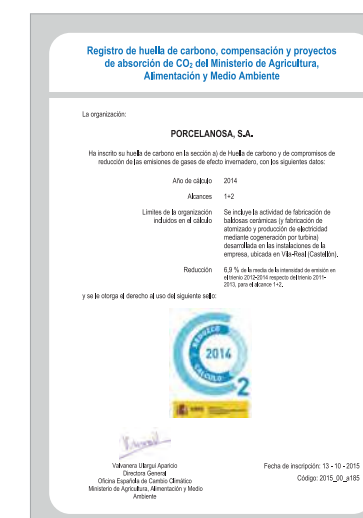





### CERTIFICADOS / CERTIFICATES



#### ISO 14021

FIEL A SU COMPROMISO CON EL MEDIO AMBIENTE, PORCELANOSA HA DESARROLLADO STON-KER® Y PAR-KER® ECOLOGIC, UNA COLECCIÓN DE BALDOSAS FABRICADAS CON MATERIAL REICLADO PROVENIENTE DEL PROPIO PROCESO DE PRODUCCIÓN.

EL SOPORTE DE STON-KER® Y PAR-KER® ECOLOGIC SE ELABORA A PARTIR DE MATERIAL REICLADO DE PRECONSUMO (TIESTO CRUDO Y POLVO DE ASPIRACIÓN) QUE ES REINCORPORADO AL PROCESO DE PRODUCCIÓN. LA PRODUCCIÓN DE STON-KER® Y PAR-KER® ECOLOGIC SUPONE UNA NOTABLE REDUCCIÓN EN EL CONSUMO DE MATERIAS PRIMAS (ADEMÁS DE MINIMIZAR EL IMPACTO AMBIENTAL ASOCIADO A LA EXTRACCIÓN Y TRANSPORTE DE LAS MISMAS), ASÍ COMO UN SIGNIFICATIVO AHORRO ENERGÉTICO EN LA PRODUCCIÓN DE BALDOSAS CERÁMICAS.

EL CONTENIDO EN MATERIAL REICLADO, SUPERIOR AL 95%, SE RECOGE EN LA DECLARACIÓN AMBIENTAL DE PRODUCTO, CERTIFICADO POR ISO 14021, Y QUE CERTIFICA A TRAVÉS DE UN ORGANISMO EXTERNO DE CONFIANZA EL CARÁCTER ECOLÓGICO DE LA SERIE.

LA UTILIZACIÓN DE STON-KER® Y PAR-KER® ECOLOGIC EN EL REVESTIMIENTO DE EDIFICIOS APORTA VALORACIÓN ADICIONAL (PUNTOS EXTRA) EN LA EVALUACIÓN DE LOS MISMOS POR LOS PRINCIPALES REFERENCIALES EXISTENTES EN EL MERCADO (LEED, BREEAM, VERDE,...)

*IN LINE WITH ITS COMMITMENT TO THE ENVIRONMENT, PORCELANOSA HAS DEVELOPED STON-KER® AND PAR-KER® ECOLOGIC, A COLLECTION OF TILES MANUFACTURED WITH RECYCLED MATERIAL RECOVERED FROM THE PRODUCTION PROCESS.*

*THE BASIC MATERIAL USED TO MANUFACTURE STON-KER® AND PAR-KER® ECOLOGIC COMES FROM PRE-CONSUMER RECYCLED MATERIAL (RAW CLAY AND POWDER) THAT IS REINCORPORATED INTO THE PRODUCTION PROCESS. THE PRODUCTION OF STON-KER® AND PAR-KER® ECOLOGIC RESULTS IN A NOTABLE REDUCTION IN RAW MATERIAL CONSUMPTION (IN ADDITION TO MINIMISING THE ENVIRONMENTAL IMPACT ASSOCIATED TO THE EXTRACTION AND TRANSPORT OF THE SAME), AND SIGNIFICANT ENERGY SAVING IN THE PRODUCTION OF CERAMIC TILES.*

*THE CONTENT OF THE RECYCLED MATERIAL, OVER 95%, IS QUANTIFIED IN THE ENVIRONMENTAL PRODUCT DECLARATION, CERTIFIED BY ISO 14021, AND WHICH CERTIFIES, THROUGH A TRUSTED EXTERNAL ORGANISATION, THE ECOLOGICAL NATURE OF THE SERIES.*

*THE USE OF STON-KER® AND PAR-KER® ECOLOGIC IN THE COVERING OF BUILDINGS, GIVES ADDITIONAL VALUE (EXTRA POINTS) IN THE ASSESSMENT BY THE MARKET'S LEADING CERTIFICATION BODIES (LEED, BREEAM, VERDE, ETC.)*



### CERTIFICADOS / CERTIFICATES



#### ISO 50001:2011

PORCELANOSA HA IMPLANTADO UN SISTEMA DE GESTIÓN ENERGÉTICA DE ACUERDO A LA NORMA ISO 50001, COMO UNA HERRAMIENTA QUE PERMITA LA REDUCCIÓN DE LOS CONSUMOS DE ENERGÍA Y CONSECUENTEMENTE LAS EMISIONES DE GASES DE EFECTO INVERNADERO. A TRAVÉS DE LA MEJORA DEL DESEMPEÑO ENERGÉTICO, SE PERSIGUE FOMENTAR LA MÁXIMA EFICIENCIA EN TODOS NUESTROS PROCESOS, REFRENDANDO DE ESTA FORMA EL CLARO COMPROMISO MEDIOAMBIENTAL ADOPTADO DESDE EL INICIO DE LA ACTIVIDAD.

*PORCELANOSA HAS IMPLEMENTED AN ENERGY MANAGEMENT SYSTEM IN ACCORDANCE WITH THE ISO 50001 STANDARD, DESIGNED TO ACT AS A TOOL FOR THE REDUCTION OF ENERGY CONSUMPTION AND CONSEQUENTLY THE EMISSION OF GREENHOUSE GASES. BY IMPROVING ENERGY PERFORMANCE LEVELS, THE AIM IS TO PROMOTE MAXIMUM EFFICIENCY IN ALL OUR PROCESSES, THEREBY FURTHER ENDORSING THE CLEAR ENVIRONMENTAL COMMITMENT MAINTAINED BY THE COMPANY THROUGHOUT ITS HISTORY.*





### CERTIFICADOS / CERTIFICATES



#### ISO 9001:2015

CON LAS PREMISAS DE MEJORA CONTINUA Y SATISFACCIÓN DE CADA CLIENTE, PORCELANOSA ASEGURA LAS PRESTACIONES, TANTO ESTÉTICAS COMO TÉCNICAS, DE SUS PRODUCTOS A TRAVÉS DE UN SISTEMA DE GESTIÓN DE CALIDAD CERTIFICADO POR LA NORMA ISO 9001, APLICADO AL DISEÑO, PRODUCCIÓN, DISTRIBUCIÓN Y COMERCIALIZACIÓN DE PAVIMENTOS, REVESTIMIENTOS Y PIEZAS ESPECIALES CERÁMICAS.

WITH A PHILOSOPHY BASED ON-GOING IMPROVEMENTS AND CUSTOMER SATISFACTION, PORCELANOSA GUARANTEES THE AESTHETIC AND TECHNICAL CHARACTERISTICS OF ITS PRODUCTS BY APPLYING A QUALITY-CONTROL SYSTEM CERTIFIED BY ISO 9001 TO THE DESIGN, PRODUCTION, DISTRIBUTION AND COMMERCIALISATION OF ITS WALL AND FLOOR TILES AND TRIMS.



### CERTIFICADOS / CERTIFICATES



#### ISO 14001:2015

EN EL CONTEXTO DE UNA LEGISLACIÓN CADA VEZ MÁS EXIGENTE, PORCELANOSA DEMUESTRA SU SÓLIDO COMPROMISO MEDIOAMBIENTAL MEDIANTE LA ADOPCIÓN DE UN SISTEMA DE GESTIÓN CERTIFICADO POR LA NORMA ISO 14001, TRANSMITIENDO DE ESTA FORMA NUESTRA POLÍTICA DE RESPETO Y PREOCUPACIÓN POR EL MEDIO AMBIENTE.

WITH A FRAMEWORK OF INCREASINGLY STRICT LEGISLATIVE CONTROLS, PORCELANOSA HAS DEMONSTRATED ITS FIRM COMMITMENT TO THE ENVIRONMENT WITH THE INTRODUCTION OF A MANAGEMENT SYSTEM CERTIFIED TO ISO 14001, THUS REFLECTING ITS RESPECT AND CONCERN FOR THE ENVIRONMENT.







## CERTIFICADOS / CERTIFICATES

### DECLARACIÓN AMBIENTAL DE PRODUCTOS DE LA CONSTRUCCIÓN (DAPc)

DAPcons.002.015



EL SISTEMA DESARROLLADO DE DECLARACIONES AMBIENTALES DE PRODUCTOS DE LA CONSTRUCCIÓN (DAPc) SE HA CREADO PARA FACILITAR LA ADAPTACIÓN DEL SECTOR DE LA CONSTRUCCIÓN A UN NUEVO MODELO MÁS COHERENTE Y SOSTENIBLE MOTIVADO POR UN MAYOR INTERÉS SOCIAL PARA DISMINUIR EL IMPACTO AMBIENTAL, INCLUIDO EN EL MUNDO DE LA CONSTRUCCIÓN, UNO DE LOS DE MAYOR IMPACTO, TRATARSE DE UNA INICIATIVA PIONERA EN ESPAÑA Y ESTAR AL NIVEL DE ALGUNOS PAÍSES PUNTEROS DE EUROPA EN ESTE TEMA Y LA CREACIÓN DE NUEVAS EXIGENCIAS MEDIOAMBIENTALES POR LA LEGISLACIÓN. FUNDAMENTALMENTE, SE TRATA DE CONSEGUIR UNA MEJORA AMBIENTAL DE LA CONSTRUCCIÓN DESDE UN BUEN CONOCIMIENTO DE LOS IMPACTOS DE CADA UNO DE LOS COMPONENTES ASÍ COMO LA TRANSPARENCIA MEDIOAMBIENTAL DEL SECTOR. (FUENTE: [HTTP://ES.CSOSTENIBLE.NET/DAPc/OBJETIVOS/](http://ES.CSOSTENIBLE.NET/DAPc/OBJETIVOS/))

DAPcons.002.016



### DECLARACIÓN AMBIENTAL DE PRODUCTOS DE LA CONSTRUCCIÓN (DAPc)

THE SYSTEM DEVELOPED FOR ENVIRONMENTAL DECLARATIONS FOR BUILDING PRODUCTS (EPD) HAS BEEN CREATED IN ORDER TO HELP THE CONSTRUCTION SECTOR ADAPT TO A NEW, MORE COHERENT AND MORE SUSTAINABLE MODEL, MOTIVATED BY GROWING SOCIAL INTEREST IN REDUCING ENVIRONMENTAL EFFECTS IN THE FIELD OF CONSTRUCTION, ONE OF THE SECTORS THAT CAUSES THE GREATEST IMPACT. THIS IS A PIONEERING INITIATIVE IN SPAIN, AIMED AT ACHIEVING THE SAME LEVEL AS SOME OF THE LEADING EUROPEAN COUNTRIES IN THIS AREA, AND IN LINE WITH THE DEMANDS RESULTING FROM NEW ENVIRONMENTAL LEGISLATION. THE GOAL IS TO ACHIEVE ENVIRONMENTAL IMPROVEMENTS IN THE CONSTRUCTION SECTOR, BASED ON A THOROUGH UNDERSTANDING OF THE IMPACTS CAUSED BY EACH OF ITS COMPONENTS, AS WELL AS THE ENVIRONMENTAL TRANSPARENCY OF THE SECTOR. (SOURCE: [HTTP://ES.CSOSTENIBLE.NET/DAPc/OBJETIVOS/](http://ES.CSOSTENIBLE.NET/DAPc/OBJETIVOS/))



## INSTRUCCIONES DE COLOCACIÓN / INSTALLATION INSTRUCTIONS

### HUELLA TÉCNICA / TECHNICAL TREAD

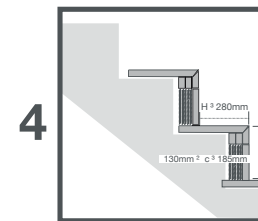
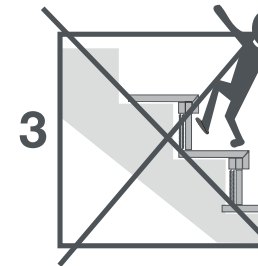
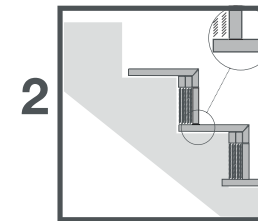
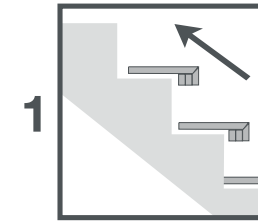

#### COLOCACIÓN:

- Asegurarse que el soporte estructural esté enrasado y preparado (limpio de polvo, aceites...).
- El sentido de la colocación será desde abajo hacia arriba (sentido ascendente). (1)
- Utilizar herramientas de colocación adecuadas, así como adhesivos específicos para la baldosa y soporte implicados.
- Manipular con cuidado.
- La contrahuella debe apoyar sobre la pieza base (primer escalón) o sobre la huella (sucesivos peldaños). (2)
- Colocar todas las huellas, dejando la colocación de las contrahuellas para el final. (1)
- Maestrar la verticalidad sobre la que se coloca la contrahuella hasta el nivel que nos permita, una vez completado el fraguado, colocando en capa fina, llegar al límite exterior de la huella o a la distancia específica para dejar la diferencia de profundidad deseada entre huella y contrahuella. Según el Código Técnico de la Edificación, para escaleras previstas para evacuación ascendente, o las utilizadas preferentemente por niños, ancianos o personas con discapacidad, no se permite bocel ni relaste (huella y contrahuella deben quedar perfectamente alineados), para evitar tropiezos y caídas. (3)
- Cortar la contrahuella a la medida establecida para cumplir con el dimensionamiento inicial de la escalera (el Código Técnico de la Edificación establece que para escaleras de uso general, la altura del peldaño debe de ser inferior a 18,5 cm y superior a 13 cm, además, la superficie pisable (huella) debe ser superior a 28 cm. (4)
- Las baldosas deben quedar perfectamente macizadas, sin huecos, para evitar potenciales fuentes de roturas o despegues. (2)
- Se debe proceder al rejuntado entre las distintas piezas, empleando para ello los materiales recomendados por Porcelanosa.
- Proteger el material ya colocado hasta que finalice la obra, con el fin de evitar daños sobre la superficie cerámica durante los trabajos posteriores.

#### INSTALLATION:

- Make sure that the substrate is flat and ready for laying the treads (with no dust, oil or grase etc).
- Start to lay the treads from the bottom of the staircase (moving upwards). (1)
- Use suitable tile-laying tools and the right adhesive for the tiles and substrate.
- Handle the tiles with care.
- The stair riser of the first step should rest on the bottom floor tile. Subsequent risers should rest on the stair tread below each one. (2)
- Lay all the stair treads before proceeding to lay the risers. (1)
- Level the vertical substrate for each stair riser so that, once the cement has set and the stair riser has been laid using the thin bed method, it reaches the outer edge of the stair tread above it or leaves the desired joint between them. According to the Spanish Building Code, when the stairs are used for upward evacuation or mainly used by children, the elderly or the disabled, stair nosings or overhanging treads are forbidden. (The tread and riser must be edge to edge). (3)
- Cut the stair riser to the right size to comply with the initial plans for the stairs. (The Spanish Building Code establishes that stairs for general use should have steps with a height of over 13 cm and less than 18,5 cm and that the treads should be bigger than 28 cm). (4)
- Bond the tiles solidly, making sure that there are no voids, to prevent them from breaking or coming loose. (2)
- Grout the tiles using materials recommended by Porcelanosa.
- Protect the tiled surfaces until all on-site work has been completed in order to prevent them from being damaged during subsequent tasks.



## INSTRUCCIONES DE COLOCACIÓN

### BALDOSAS CERÁMICAS

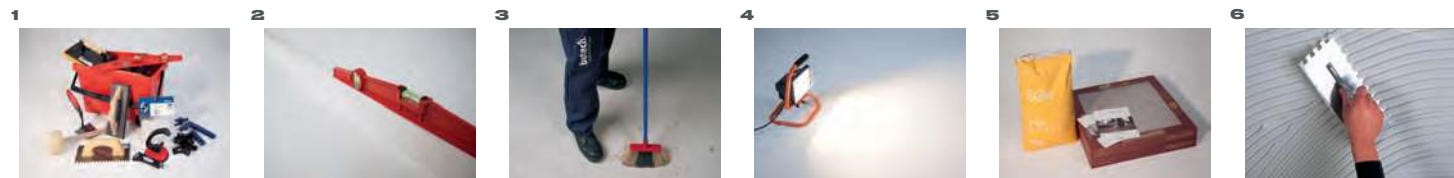

1- La colocación de cerámica requiere de personal cualificado, con experiencia demostrada y herramientas y útiles adecuados: llanas dentadas, crucetas, mazas de goma, ventosas para la colocación y llanas de goma, esponjas y cubetas para el rejuntado. Revisar previamente la información contenida en los embalajes y respetar escrupulosamente las recomendaciones del fabricante.

2- Comprobar que el soporte que se va a revestir sea estable y el fondo de colocación adecuado para la colocación de cerámica: superficie con textura rugosa no disgregable, perfectamente nivelada y sin defectos de planitud. Se recomienda la impermeabilización de ambientes húmedos.

3- La superficie a revestir debe estar totalmente limpia de polvo o cualquier otra sustancia que pueda perjudicar la adhesión de las baldosas. Para colocaciones específicas (sistemas de calefacción radiante, fachadas con anclajes mecánicos, cerámica en techos ó resolución de parámetros particulares de proyecto) solicitar información concreta adicional para cada situación.

4- La iluminación del lugar de trabajo ha de ser lo suficientemente intensa como para detectar con facilidad cualquier defecto de colocación, especialmente "cejas" entre baldosas. Se recomienda trabajar con focos eléctricos y una iluminación superior a la de uso.

5- Elegir el tipo de adhesivo en función del ambiente y baldosa a revestir. La elección de la baldosa y del adhesivo son críticos en el comportamiento posterior del conjunto. Los factores a tener en cuenta son: tipo de material cerámico, formato de la baldosa, soporte de colocación y destino de uso (tráfico al que va ser sometido, requisitos de seguridad frente a caídas, ...). En los catálogos de PORCELANOSA encontrará referencias para el ámbito de uso y la resistencia al deslizamiento, así como del adhesivo butech recomendado para cada modelo.

6- El único sistema de colocación recomendado es la colocación en capa fina y llana dentada. En baldosas con formato superior a 1,000 cm<sup>2</sup>, se recomienda la técnica de doble encolado, con aplicación del adhesivo tanto sobre el soporte como en el dorso de la baldosa cerámica.

Es fundamental retirar los restos de material de agarre que puedan quedar sobre la superficie de la baldosa antes de su fraguado, asegurándose de dejar la junta limpia para facilitar las labores de rejuntado. No utilizar herramientas metálicas ni elementos contundentes en operaciones de limpieza que puedan deteriorar la superficie de las baldosas.

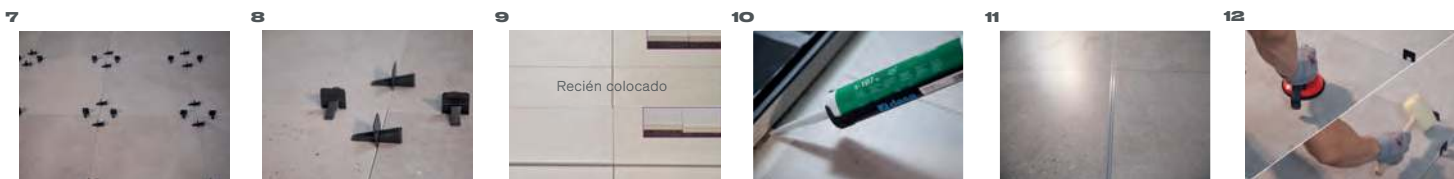

7- Todas las baldosas cerámicas y en especial las rectificadas, deben manipularse con el máximo cuidado, para evitar su rayado, despuntado o desconchado. Antes de iniciar la colocación, comprobar que la baldosa no presente ningún defecto.

8- Las juntas de colocación serán de al menos 1,5 mm en colocaciones interiores y 5 mm en pavimentos exteriores. En colocaciones a junta trabada, realizar la colocación a 3/4 de pieza. Se recomienda el uso de crucetas autonivelantes\*.

\* Antes de utilizar el sistema de crucetas anti-nivelantes, realizar una prueba previa con el tipo de revestimiento o pavimento a colocar y comprobar que durante el proceso de rotura del separador no se dañe la baldosa, especialmente en azulejos con relieve o rectificadas sin biselar. Consultar las normas de colocación nacionales y respetar el ancho de junta mínimo indicado para el tipo de baldosa e instalación a realizar.

9- Respetar las recomendaciones del fabricante en la preparación y utilización de los adhesivos. No aplicar el adhesivo en un espesor final superior al indicado en el saco, comprobar la capacidad humectante del adhesivo y presionar la cerámica sobre el material de agarre mediante un movimiento de vaivén. Distribuir el adhesivo de forma homogénea bajo la baldosa. Espesores diferentes pueden producir defectos tipo "ceja" por retracción diferencial del material de agarre. Cuando deba continuarse una colocación a partir de una cerámica ya colocada, estimar la posible retracción y tomar un nivel que la compense.

10- Las juntas perimetrales estarán presentes en esquinas, cambios de plano del pavimento y cambios de material. Se recomienda cubrir con el zócalo o la propia baldosa y sellar con una masilla elástica. Anchura mínima de la junta: 8mm.

11- Respetar las juntas estructurales. Realizar las juntas de movimiento según las indicaciones del técnico de la obra. En general, no diseñar áreas superiores a 50-70 m<sup>2</sup> en interiores y la mitad en exteriores. Anchura mínima de la junta: 8 mm.

12- Tanto durante la fase de colocación como antes de finalizar la jornada, revisar la calidad del trabajo realizado antes de que el material de agarre complete su tiempo de ajuste y corregir los efectos mediante el uso de ventosas y mazas de goma.



13- Antes de proceder al rejuntado, revisar que el material de agarre haya endurecido. Retirar los restos de crucetas, limpiar las juntas de colocación en toda su longitud, anchura y profundidad y finalmente, comprobar que no quede humedad en el interior de la junta.

14- El relleno de juntas se debe realizar cuando las baldosas se encuentren perfectamente adheridas al soporte. En el caso del pavimento, se deben respetar las recomendaciones del fabricante de adhesivos, con el fin de dejar transcurrir el tiempo suficiente antes de ser pisado o sometido a cualquier tipo de carga. Se pueden evitar así despegues o roturas prematuras.

15- Respetar las recomendaciones del fabricante en la preparación y utilización de los materiales de junta. Comprobar que el material y herramienta elegida no dañen la superficie de la cerámica. El material de rejuntado se aplicará con llana de goma. En los catálogos de PORCELANOSA encontrará el material de butech recomendado para cada modelo.

16- En zonas de agua se debe utilizar material de rejuntado de naturaleza epoxi y cubrir los encuentros con bañera ó ducha con silicona para evitar filtraciones de agua que generan problemas de absorción y potenciales cambios de tonalidad y expansión por humedad.

17- Proteger el pavimento contra cargas prematuras, otros trabajos de obra y condiciones climáticas adversas. Se recomienda cubrir los pavimentos con láminas o paneles que eviten la acumulación de suciedad y protejan del rayado, la abrasión y golpes.

18- En la limpieza de obra, utilizar productos compatibles con la resistencia química de las baldosas. Evitar el uso de detergentes sólidos con partículas abrasivas, así como agentes de limpieza que contengan ácido fluorhídrico (HF). Este ácido ataca el esmalte y causa daños irreparables en la cerámica.



## INSTALLATION INSTRUCTIONS

### CERAMIC TILES

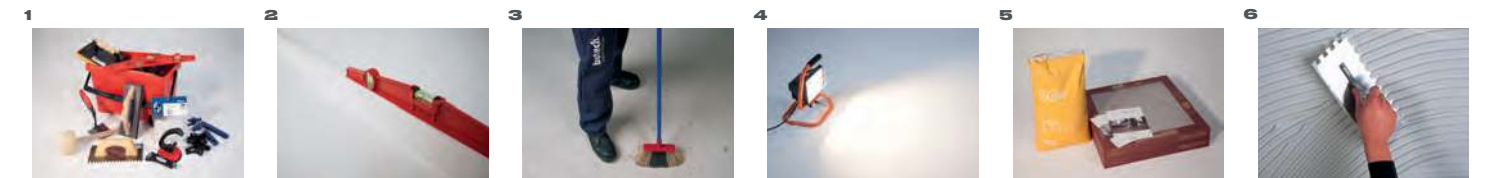

1- Installation of ceramic tiles should be carried out by skilled personnel, with demonstrable experience and appropriate tools and equipment, (i.e. toothed trowels, tile spacers, rubber mallets and suction cups for installation, and rubber trowels, sponges and containers for grouting). Check the information contained on the packaging beforehand, and meticulously follow the manufacturer's recommendations.

2- Check that the substrate to be covered is stable and the base is suitable for installing ceramic tiles: rough texture, not friable completely flat and level. We recommend that all damp areas are waterproofed.

3- Surfaces to be tiled must be completely free of dust or any other substance which could impair tile adhesion. For specific installations (radiant heating systems, façades with mechanical anchors, ceramics on roofs/ceilings or particular design constraints) request additional information specifically for each application.

4- The workplace must be adequately lit to detect possible installation defects easily, especially lippage between tiles. Electric site lighting is recommended, to provide brighter than normal light.

5- Choose the type of adhesive depending on the conditions and tiles used. The choice of tile and adhesive are critical to the subsequent performance of the entire work. Factors to take into account are: the type of ceramic material, tile format, substrate and end use (any traffic it will be subjected to, safety requirements in respect of falls ...). PORCELANOSA catalogues contain recommendations in respect of use and slip resistance, as well as the butech adhesive recommended for each design.

6- The only fixing system recommended is installation on a thin layer using a toothed trowel. A double bonding technique (with adhesive applied to both the substrate and the back of the ceramic tile) is recommended for tiles with a format larger than 1,000 cm<sup>2</sup>. It is essential to remove any traces of bonding material that may remain on the surface of the tile prior to setting, ensuring that the joint is left clean to make grouting easier. Do not use metal tools or blunt elements in cleaning operations that could damage the surface of the tiles.

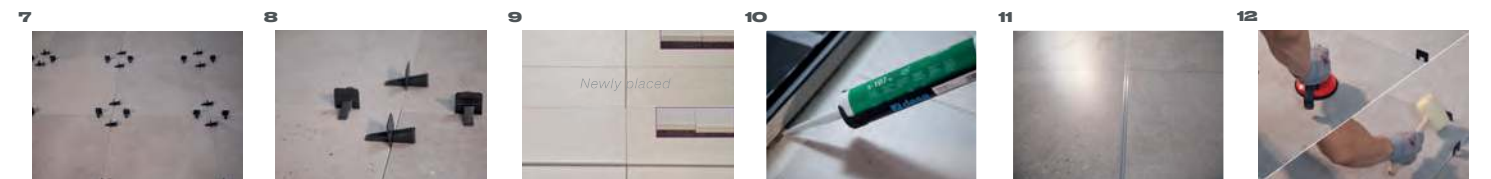

7- Great care should be taken when handling to avoid scratching, breaking or chipping the tiles, especially rectified tiles. Prior to installation, check that the tiles are free from defects.

8- Grout joints should be at least 1,5mm for interior flooring and 5mm for exterior paving. For installations with offset joints, stagger the tiles at the 3/4 point. Self-levelling tile spacers are recommended.

9- Follow manufacturer's recommendations in respect of the preparation and use of adhesives. Do not apply adhesive at a thickness greater than indicated on the label, check the wetting capacity of the adhesive and press the ceramic tile into the bonding material with a side to side movement. Distribute the adhesive evenly under the tile. Different thicknesses may produce lippage defects caused by differential shrinkage of the bonding material. When positioning adjacent to previously installed ceramic tiles, estimate possible shrinkage and compensate for this.

10- Edge joints occurring at corners, changes of paving level and changes of material should be covered with tile trim or a tile itself and sealed with flexible sealant. Minimum joint width: 8 mm.

11- Take account of structural joints. Movement joints should be positioned as directed by the project designer. In general, do not design areas greater than 50-70 m<sup>2</sup> for interiors and half that for exteriors. Minimum joint width: 8 mm.

12- Both during installation and at the end of the day, check the quality of the work carried out before the bonding material sets. Correct any defects using suction cups and rubber mallets.



13- Prior to grouting, check that the bonding material has hardened. Remove the tile spacers, clean the joints along their length, width and depth, and check the joint is not damp.

14- Joints should be grouted when the tiles are completely fixed to the substrate. In respect of paving, follow the recommendations of the adhesive manufacturer to ensure sufficient time is allowed before the floor is walked on or subjected to load. In this way movement and/or breakages are avoided.

15- Follow the manufacturer's recommendations in respect of the preparation and use of grouting materials. Ensure that the material and tools chosen do not damage the tile surface. The grout should be applied using a rubber trowel. PORCELANOSA catalogues contain details of the butech materials recommended for each design.

16- Wait for the grout to start to dry, then clean with a sponge dampened in clean water. Do not allow the grout to harden on the tile, especially on textured tiles. Do not soak the joint with excess water.

17- Protect the paving against premature loading, other construction work and adverse weather. We recommend covering the paving with sheets or boards to avoid a build-up of dirt and to protect from scratches, abrasion and impact.

18- For cleaning, use products compatible with the chemical resistance of the tiles. Do not use strong detergents containing abrasives or cleaning agents containing hydrofluoric acid (HF). This acid attacks the glazing and will cause irreparable damage to the tiles.





## INSTRUCCIONES DE LIMPIEZA Y MANTENIMIENTO

### BALDOSAS CERÁMICAS

1. **COMPORTAMIENTO HIGIÉNICO DE LAS BALDOSAS CERÁMICAS**  
El proceso de fabricación de las baldosas cerámicas comprende entre sus etapas, una cocción a alta temperatura (del orden de 1100°C-1200°C), e incluso superiores en el caso de porcelánico. Esta temperatura produce reacciones químicas entre los diferentes componentes de la pasta y la decoración así como transformaciones físicas cuyas principales consecuencias son la formación de una estructura dura, compacta y resistente y la reacción e inmovilización de los metales pesados al formarse compuestos que se caracterizan por su alta inactividad química.

Por ello, la presencia de cualquier microorganismo queda descartada al someter al producto durante su fabricación a regímenes de temperatura que hacen imposible su supervivencia.

Los revestimientos y pavimentos cerámicos, si están correctamente instalados (con los materiales de agarre y rejuntado apropiados a su función de uso), representan la alternativa mas eficaz, cómoda y segura para mantener las condiciones adecuadas de higiene y limpieza.

Su superficie impermeable, evita la intromisión de líquidos, vapores, sustancias tóxicas o cualquier otro contaminante; evita a su vez, la generación de reacciones, putrefacciones, eflorescencias o cultivo orgánico por sus características no porosas.

Por otra parte, su resistencia química, les hace susceptibles de soportar, sin sufrir alteración, productos detergentes y desinfectantes agresivos, difícilmente utilizable sobre otros materiales de revestimiento y pavimento. Así mismo, por su equipotencialidad eléctrica y la no-predisposición al acumulo de cargas electrostáticas, los revestimientos cerámicos contribuyen al confort fisiológico y evitan la captación del polvo ambiental eléctricamente activo.

La naturaleza de la superficie cerámica evita cualquier fenómeno de adherencia y si ésta se produce por medio de un vehículo intermedio (grasa, barro, etc.) es fácilmente eliminable. Este mismo razonamiento sirve para exaltar las positivas propiedades higiénicas del producto cerámico respecto al depósito, acumulación y anidación de microorganismos y sustancias patógenas y alérgicas.

#### 2. PRECAUCIONES DURANTE LA COLOCACIÓN:

a) La retirada de los restos de material de rejuntado se debe realizar utilizando una esponja humedecida en agua limpia. Esta operación no se debe prolongar en el tiempo, ya que un excesivo tiempo de contacto con la superficie esmaltada, dificulta la posterior eliminación del mismo, en especial aquellos modelos que su superficie presenta relieves.

b) Se hace imprescindible, en la colocación del pavimento, la protección del material ya colocado con sistemas adecuados, para impedir posibles daños hasta la finalización de la obra, debido a la presencia de material abrasivo y continuo trasiego de herramientas. De esta forma, además de la protección de la superficie cerámica, se facilitan así las posteriores tareas de limpieza.

c) Se deben evitar agentes de limpieza que contengan ácido fluorhídrico (HF) y detergentes sólidos que contengan partículas susceptibles de abrasionar el material. El ácido fluorhídrico eliminaría totalmente la superficie esmaltada del material, causando así daños irreparables.

#### 3. CONSEJOS DE MANTENIMIENTO

Los pavimentos y revestimientos cerámicos porosos vidriados y los no porosos sin vidriar no necesitan ningún mantenimiento después de concluir todas las operaciones de puesta en obra. De entre todos los materiales y productos empleados como revestimientos y pavimentos, la cerámica es la que presenta menores exigencias en este campo.

Con independencia de las características del vidriado, características intrínsecas como la resistencia a la abrasión superficial o al rayado, vienen directamente relacionadas con el agente abrasivo que se coloca como fase intermedia entre el pavimento y la suela del calzado que transita sobre éste. Para evitar desgaste prematuro, es recomendable

mantener los suelos debidamente limpios, a lo que ayuda sobremanera la colocación de alfombras en la entrada a locales con acceso directo desde la calle o el jardín.

Los pavimentos y revestimientos vidriados tienen suficiente para la limpieza ordinaria con una pasada con mocho o esponja humedecida para devolver el aspecto superficial original, y detergente neutro. Si con el transcurso del tiempo, se observa una superficie de aspecto plástico con mayor dificultad para mantenerse limpia, de forma general, suele deberse a la formación de una capa superficial. Esa capa resulta difícil de eliminar con la fregona convencional. Para eliminarla y conseguir la superficie original, se debe emplear una disolución ligeramente ácida (añadir salfuman en una proporción del 5% en agua) y ejercer una frotación más intensa (cepillo de puas de plástico duro). Aclarar posteriormente con suficiente agua para eliminar la suciedad desincrustada.

Para la limpieza ordinaria, se recomienda utilizar fregona o esponja humedecida. Es necesario renovar el agua de limpieza, frecuentemente, para no volver a depositar sobre la superficie la suciedad eliminada con anterioridad. Es aconsejable utilizar productos de limpieza de carácter neutro.

El empleo de un mocho de microfibras y agua muy caliente favorecerá el secado de la superficie y minimizará la creación de una capa superficial sobre la baldosa, hecho que facilita el posterior marcado de las huellas y una mayor propensión a captar la suciedad.

No conviene utilizar agentes de limpieza que contengan ceras en su composición, ya que terminan formando una película sobre la baldosa cerámica que favorece la absorción y retención de sustancias extrañas, originando manchas fácilmente detectables y más difíciles de eliminar con las operaciones de limpieza ordinarias.

Si es el caso del baño, donde se suelen formar incrustaciones de jabón o de carbonatos del agua, conviene efectuar limpiezas periódicas con un producto detergente adecuado, dejándolo en reposo durante unos minutos antes de proceder a su eliminación.

Eliminación de manchas e incrustaciones extraordinarias

Para limpiezas extraordinarias, por ejemplo las que son necesarias sobre superficies que han estado abandonadas de la limpieza durante mucho tiempo, se deben emplear detergentes en polvo o líquidos, aplicados frotando con una esponja o estropajo.

Especial atención merece las juntas entre baldosas, que deberán restaurarse en caso de falta de integridad o estanqueidad, con sellantes adecuados. No es aconsejable la utilización de cuchillas o espátulas metálicas sobre la superficie vidriada y tampoco es aconsejable el uso de productos concentrados cuando no se posea seguridad sobre la clase de resistencia química del revestimiento o pavimento.

Accidentalmente, nos podemos encontrar con que el pavimento o revestimiento cerámico se manche por acción de alguna o algunas sustancias de diversa naturaleza. Existen procedimientos físicos y químicos para la eliminación de manchas e incrustaciones, debiéndose adoptar el más idóneo al tipo de baldosa y naturaleza de la mancha.

Los métodos físicos se basan en la utilización de detergentes o abrasivos de gran finura, cuya función es el despegue físico de la mancha y el alejamiento de la superficie cerámica.

Los métodos químicos se basan en la reacción química entre la mancha o incrustación y el detergente que la disuelve o decolora.

En baldosas vidriadas no es aconsejable usar ácidos concentrados de naturaleza desconocida y que puedan atacar la superficie, por desconocerse su resistencia química.

En la tabla siguiente, y a modo de ejemplo, se exponen algunos productos adecuados para el tratamiento de determinadas manchas. Cuando no se conozca la naturaleza de la mancha conviene realizar

pruebas con detergentes diferentes, enjuagando la superficie con agua y secándola después de cada prueba. En otros casos, puede resultar eficaz repetir el tratamiento varias veces o emplear agua caliente para favorecer la reacción.

Adhesivo cementoso	Detergente ácido
Café, té, alimentos, fruta, zumo o cosméticos.	Detergente normal disuelto en agua caliente.
Grasas	Bicarbonato y agua, jabón neutro (utilizar estropajo suave).
Manchas de lápiz	Goma de borrar blanda.
Manchas orgánicas	Detergente alcalino.
Pintura de rotulador	Disolvente (aguarrás, acetona, etanol).
Restos de goma	Detergente alcalino, disolvente.
Restos de junta	Detergente ácido.
Restos de silicona	Agua oxigenada o solución diluida de lejía (en superficies lisas y no susceptibles de rallado, puede utilizarse raspador de vitrocerámica).
Sangre	Agua oxigenada o solución diluida de lejía.
Tintas	Solución diluida de lejía.
Yodo o bromo	Detergente ácido, agua oxigenada, solución diluida de lejía, amoniaco.

En cualquier caso, y ante la más mínima duda, conviene consultar la ficha técnica del producto.

Restos de silicona: Cuchilla para limpiar vitrocerámica en superficies lisas y que no sean susceptibles de rayado. Para superficies con relieve o brillantes delicadas frente al rayado, se puede utilizar una mezcla de acetona y éter a partes iguales, aplicar sobre la silicona y esperar a que se desprenda.

Marcas de costilla (dorso de la pieza) sobre la superficie cerámica: Alúmina en polvo disuelta en agua y ayudarse de máquina rotativa con disco 3M. Las características del disco deben ser elegidas en función de la resistencia superficial.

No se deben emplear en la limpieza periódica sistemas rotativos o mecánicos con abrasivos de distinta naturaleza, ya que pueden modificar el brillo inicial en distinta medida, según intensidad del tratamiento e incluso en condiciones extremas, según presión y abrasivo utilizado, deteriorar la superficie cerámica.

Igualmente, al efectuar cualquier método de limpieza que se desvie del convencional, conviene realizar un ensayo previo en una zona concreta antes de aplicar el tratamiento sobre toda la superficie. Así, nos aseguraremos de la inercia o reactividad de la superficie cerámica ante tal método.

## CLEANING RECOMENDATIONS FOR CERAMIC TILES

### CERAMIC TILES

#### 1. HYGIENIC PERFORMANCE OF CERAMIC TILES

*The manufacturing process for ceramic tiles includes firing at high temperature (around 1100°C-1200°C), and even higher temperatures in the case of porcelain tiles. This temperature causes chemical reactions between the different components in the tile body and the glaze, as well as physical transformations whose main results are the creation of a hard, compact and highly resistant structure, and the reaction and immobilisation of heavy metals, by forming compounds characterised by their high level of chemical inactivity.*

*As a result, it is impossible for any microorganisms to be present, as the high temperatures used during the manufacturing process make it impossible for them to survive.*

*If ceramic wall and floor tiles are correctly laid using suitable bonding and grouting materials for their type of use, they are the most effective, comfortable and safe alternative for maintaining correct levels of hygiene and cleanliness.*

*Their impermeable surface prevents the absorption of any type of liquids, vapours, toxic substances or any other type of contaminant, as well as the production of reactions, putrefaction, efflorescence or organic cultures, due to their non-porous features.*

*Also, their chemical resistance means they are capable of withstanding aggressive detergents and disinfectants without any alteration, which could not be used with other types of wall and floor coverings. The fact that they cannot become electrostatically charged means that they contribute towards physiological comfort and do not attract electrically charged dust in the atmosphere.*

*Ceramic tile surfaces are resistant to any type of adherence, and any substance that does become adhered due to the presence of materials such as grease or mud can be easily removed. This also applies to the hygienic properties of ceramic tiles in response to the deposition, accumulation and development of microorganisms and pathogenic or allergic substances.*

#### 2. PRECAUTIONS WHEN LAYING TILES:

*a) Remnants of grouting material should be removed using a sponge dampened with clean water. The material should be removed as soon as possible, as if it is in contact with the glazed surface for a prolonged period it will be difficult to remove, especially on tiles with a relief patterned surface.*

*b) When laying floor tiles, it is essential to protect the tiles that have already been laid using a suitable method, to prevent damage caused by abrasive material and dragging tools across the surface. Apart from protecting the surface of the tiles, this will make any subsequent cleaning processes easier.*

*c) Do not use cleaning agents that contain hydrofluoric acid or solid detergents that contain particles that may scratch the material. Hydrofluoric acid will completely remove the glazed surface of the material, causing irreparable damage.*

#### 3. MAINTENANCE TIPS

*Glazed porous as well as unglazed non-porous floor and wall tiles do not need any type of maintenance once they have been laid. From all of the different types of materials and products used as wall and floor coverings, ceramic tiles have the least maintenance requirements.*

*Regardless of the type of glaze, intrinsic features such as resistance to surface abrasion or scratching are directly associated with the abrasive agent between the tiles and the sole of the footwear moving over them. To avoid premature wear, floors must be kept clean, placing mats at the entrance to premises with direct access from the street or gardens.*

*For ordinary cleaning, a damp mop or sponge is recommended. The cleaning water must be renewed frequently so that the previously removed dirt is not deposited on the surface again. It is advisable to use neutral cleaning products.*

*Glazed wall and floor tiles only require normal cleaning with a mop or damp sponge to return them to their original appearance, plus neutral cleaning product.*

*Cleaning agents containing waxes should not be used, as they will eventually form a film over the tile that will make them susceptible to absorbing and retaining foreign substances, causing stains that are highly visible and more difficult to eliminate using ordinary cleaning methods.*

*In bathrooms, where remnants of soap or lime scale can accumulate, tiles should be cleaned regularly with a suitable detergent product, leaving it to act for a few minutes before rinsing.*

*Removing difficult stains and incrustations. To remove difficult stains, for example on surfaces that have not been cleaned for some time, powdered or liquid detergents should be used, rubbing with a sponge or scourer. Special attention should be paid to the tile joints, as they must be restored if they are no longer intact or waterproof, using appropriate sealants.*

*Metallic blades or spatulas should not be used on glazed tile surface, or concentrated products when you do not know the chemical resistance rating of the wall or floor tiles.*

*Accidents can cause ceramic wall or floor tiles to become stained with different types of substances. Stains and incrustations can be removed using physical and chemical methods, using the most suitable method for the type of tile and the type of stain.*

*The physical methods involve using detergents or very fine abrasives, which physically remove the stain from the tile surface.*

*The chemical methods are based on a chemical reaction between the stain or incrustation and the detergent that dissolves it or discolours it.*

*Only use concentrated acids on glazed tiles if their composition is known, as certain types may affect the tile surface. The following table shows some examples of suitable products for treating specific stains. If the type of stain is unknown, different detergents should be tested, rinsing the surface with water and drying it after each test. In other cases, it may be effective to repeat the treatment several times or use hot water to help with the reaction.*

<i>Cementitious adhesive</i>	<i>Acid detergent</i>
<i>Coffee, tea, food, fruit, juice or cosmetics</i>	<i>Normal detergent dissolved in hot water</i>
<i>Greases</i>	<i>Baking soda and water, neutral soap (use a mild scouring pad)</i>
<i>Pencil stains</i>	<i>Soft eraser</i>
<i>Organic stains</i>	<i>Alkaline detergent</i>
<i>Marker paint</i>	<i>Solvent (turpentine, acetone, ethanol)</i>
<i>Rubber remnants</i>	<i>Alkaline detergent, solvent</i>
<i>Gasket remnants</i>	<i>Acid detergent</i>
<i>Silicone remnants</i>	<i>Hydrogen peroxide or diluted bleach solution (on smooth surfaces not susceptible to scratching, a vitroceramic scraper can be used)</i>
<i>Blood</i>	<i>Hydrogen peroxide or diluted bleach solution</i>
<i>Inks</i>	<i>Diluted bleach solution</i>
<i>Iodine or bromine</i>	<i>Acid detergent, hydrogen peroxide, diluted bleach solution, ammonia</i>

*In any event, if you have any doubts whatsoever, consult the technical data sheet for the product.*

*Also, when carrying out any unconventional cleaning method, first test a small zone before applying the treatment to the whole surface, checking the reaction.*





## CARACTERÍSTICAS TÉCNICAS / TECHNICAL FEATURES

MONKER - (Revestimiento - Grupo Bll\*)

NORMA - STANDARD	ENSAYO - TEST	UNE EN 14411 : 2016 ISO 13006 : 2018	VALORES - VALUES
	MEDIDA DE LONGITUD Y ANCHURA LENGTH AND WIDTH	DESVIACIÓN RESPECTO MEDIDA DE FABRICACIÓN: DEVIATION FROM MANUFACTURING MEASURE.	NO RECTIFICADOS: +0,6% MÁX 2MM NO RECTIFIED RECTIFICADOS: + 0,3 % MÁX 1MM RECTIFIED
	MEDIDA DEL GROSOR THICKNESS	DESVIACIÓN RESPECTO MEDIDA DE FABRICACIÓN: DEVIATION FROM MANUFACTURING MEASURE.	±10% MÁX 0,5MM
	MEDIDA DE LA RECTITUD DE LOS LADOS MEASUREMENT OF SIDE STRAIGHTNESS	DESVIACIÓN RESPECTO MEDIDA DE FABRICACIÓN: DEVIATION FROM MANUFACTURING MEASURE.	NO RECTIFICADOS: +0,5% MÁX 1,5MM NO RECTIFIED RECTIFICADOS: + 0,3 % MÁX 0,8MM RECTIFIED
	MEDIDA DE LA ORTOGONALIDAD SQUARENESS	DESVIACIÓN RESPECTO MEDIDA DE FABRICACIÓN: DEVIATION FROM MANUFACTURING MEASURE.	NO RECTIFICADOS: +0,5% MÁX 2MM NO RECTIFIED RECTIFICADOS: + 0,3 % MÁX 1,5MM RECTIFIED
	MEDIDA DE LA PLANITUD DE LA SUPERFICIE LATERAL - CENTRAL - ALABEO -	DESVIACIÓN RESPECTO MEDIDA DE FABRICACIÓN: DEVIATION FROM MANUFACTURING MEASURE.	NO RECTIFICADOS: +0,5% MÁX 2MM NO RECTIFIED RECTIFICADOS: + 0,4 % MÁX 1,8MM RECTIFIED
	UNE-EN ISO 10545-3	ABSORCIÓN DE AGUA WATER ABSORPTION	VALOR MEDIO > 10 %  CUMPLE LA NORMA COMPLIES WITH THE STANDARDS
	UNE-EN ISO 10545-4	MÓDULO DE ROTURA MODULUS OF RUPTURE  FUERZA DE ROTURA BREAKING STRENGTH	MÍNIMO VALOR INDIVIDUAL ≥ 12 N/mm <sup>2</sup>  > 600 N  CUMPLE LA NORMA COMPLIES WITH THE STANDARDS
	UNE-EN ISO 10545-7	RESISTENCIA A LA ABRASIÓN RESISTANCE TO ABRASION	SOLO PARA PAVIMENTO ONLY GLAZED TILES INTENDED FOR USE ON FLOORS
	UNE-EN ISO 10545-8	DETERMINACIÓN DE LA DILATACIÓN TÉRMICA LINEAL THERMAL EXPANSION COEFFICIENT	MÉTODO DE ENSAYO DISPONIBLE TEST METHOD AVAILABLE
	UNE-EN ISO 10545-9	RESISTENCIA AL CHOQUE TÉRMICO RESISTANCE TO THERMAL SHOCK	MÉTODO DE ENSAYO DISPONIBLE TEST METHOD AVAILABLE
	UNE-EN ISO 10545-11	RESISTENCIA AL CUARTEO BALDOSAS ESMALTADAS CRAZING RESISTANCE	EXIGIDO REQUIRED
	UNE-EN ISO 10545-12	RESISTENCIA A LA HELADA FROST RESISTANCE	MÉTODO DE ENSAYO DISPONIBLE NO EXIGIDO TEST METHOD AVAILABLE NOT DEMANDED
	UNE-EN ISO 10545-13	RESISTENCIA A LOS ÁCIDOS Y BASES RESISTANCE AGAINST ACIDS AND BASES  RESISTENCIA A LOS PRODUCTOS DE LIMPIEZA Y REACTIVOS DE PISCINA HOUSEHOLD DETERGENTS AND ADDITIVES FOR SWIMMING-POLS	MÉTODO DE ENSAYO DISPONIBLE TEST METHOD AVAILABLE  CLASE B MIN. CLASS B MIN.  CUMPLE LA NORMA COMPLIES WITH THE STANDARDS
	UNE-EN ISO 10545-14	RESISTENCIA A LAS MANCHAS RESISTENCE TO STAINING	MÍNIMO CLASE 3 CLASS 3 MINIMUM



## CARACTERÍSTICAS TÉCNICAS / TECHNICAL FEATURES

GRES - Grupo Bll\*

NORMA - STANDARD	ENSAYO - TEST	UNE EN 14411 : 2013 ISO 13006 : 2012	VALORES - VALUES
	MEDIDA DE LONGITUD Y ANCHURA LENGTH AND WIDTH	DESVIACIÓN RESPECTO MEDIDA DE FABRICACIÓN: DEVIATION FROM MANUFACTURING MEASURE.	NO RECTIFICADOS: +0,6% MÁX 2MM NO RECTIFIED RECTIFICADOS: + 0,3 % MÁX 1MM RECTIFIED
	MEDIDA DEL GROSOR THICKNESS	DESVIACIÓN RESPECTO MEDIDA DE FABRICACIÓN: DEVIATION FROM MANUFACTURING MEASURE.	±5% MÁX 0,5MM
	MEDIDA DE LA RECTITUD DE LOS LADOS MEASUREMENT OF SIDE STRAIGHTNESS	DESVIACIÓN RESPECTO MEDIDA DE FABRICACIÓN: DEVIATION FROM MANUFACTURING MEASURE.	NO RECTIFICADOS: +0,5% MÁX 2MM NO RECTIFIED RECTIFICADOS: + 0,3 % MÁX 0,8MM RECTIFIED
	MEDIDA DE LA ORTOGONALIDAD SQUARENESS	DESVIACIÓN RESPECTO MEDIDA DE FABRICACIÓN: DEVIATION FROM MANUFACTURING MEASURE.	NO RECTIFICADOS: +0,5% MÁX 2MM NO RECTIFIED RECTIFICADOS: + 0,3 % MÁX 1,5MM RECTIFIED
	MEDIDA DE LA PLANITUD DE LA SUPERFICIE LATERAL - CENTRAL - ALABEO -	DESVIACIÓN RESPECTO MEDIDA DE FABRICACIÓN: DEVIATION FROM MANUFACTURING MEASURE.	NO RECTIFICADOS: +0,5% MÁX 2MM NO RECTIFIED RECTIFICADOS: + 0,4 % MÁX 1,8MM RECTIFIED
	UNE-EN ISO 10545-3	ABSORCIÓN DE AGUA WATER ABSORPTION	VALOR MEDIO 0,5 < E ≤ 3 %  CUMPLE LA NORMA COMPLIES WITH THE STANDARDS
	UNE-EN ISO 10545-4	MÓDULO DE ROTURA MODULUS OF RUPTURE  FUERZA DE ROTURA BREAKING STRENGTH	≥ 30 N/mm <sup>2</sup>  > 1.100 N  >32 N/mm <sup>2</sup>  >1.800 N
	UNE-EN ISO 10545-7	RESISTENCIA A LA ABRASIÓN RESISTANCE TO ABRASION	SEGÚN LOS VALORES DEL FABRICANTE AS PER MANUFACTURER
	UNE-EN ISO 10545-8	DETERMINACIÓN DE LA DILATACIÓN TÉRMICA LINEAL THERMAL EXPANSION COEFFICIENT	MÉTODO DE ENSAYO DISPONIBLE TEST METHOD AVAILABLE
	UNE-EN ISO 10545-9	RESISTENCIA AL CHOQUE TÉRMICO RESISTANCE TO THERMAL SHOCK	MÉTODO DE ENSAYO DISPONIBLE TEST METHOD AVAILABLE
	UNE-EN ISO 10545-11	RESISTENCIA AL CUARTEO BALDOSAS ESMALTADAS CRAZING RESISTANCE	EXIGIDO REQUIRED
	UNE-EN ISO 10545-12	RESISTENCIA A LA HELADA FROST RESISTANCE	SOLO EXTERIORES EXTERIORS ONLY
	UNE-EN ISO 10545-13	RESISTENCIA A LOS ÁCIDOS Y BASES RESISTANCE AGAINST ACIDS AND BASES  RESISTENCIA A LOS PRODUCTOS DE LIMPIEZA Y REACTIVOS DE PISCINA HOUSEHOLD DETERGENTS AND ADDITIVES FOR SWIMMING-POLS	SEGÚN LOS VALORES DEL FABRICANTE AS PER MANUFACTURER  CLASE B MIN. CLASS B MIN.  CUMPLE LA NORMA COMPLIES WITH THE STANDARDS
	UNE-EN ISO 10545-14	RESISTENCIA A LAS MANCHAS RESISTENCE TO STAINING	MÍNIMO CLASE 3 CLASS 3 MINIMUM





## CARACTERÍSTICAS TÉCNICAS / TECHNICAL FEATURES

PORCELLANATO - Grupo Bia\*

NORMA - STANDARD	ENSAYO - TEST	UNE EN 14411 : 2016 ISO 13006 : 2018	VALORES - VALUES	
 UNE-EN ISO 10545-2	MEDIDA DE LONGITUD Y ANCHURA LENGTH AND WIDTH	DESVIACIÓN RESPECTO MEDIDA DE FABRICACIÓN: DEVIATION FROM MANUFACTURING MEASURE.	NO RECTIFICADOS: +0,6% MÁX 2MM NO RECTIFIED RECTIFICADOS: + 0,3 % MÁX 1MM RECTIFIED	DESVIACIÓN MÁXIMA MAXIMUM DEVIATION ±0,2%
	MEDIDA DEL GROSOR THICKNESS	DESVIACIÓN RESPECTO MEDIDA DE FABRICACIÓN: DEVIATION FROM MANUFACTURING MEASURE.	±5% MÁX 0,5MM	CUMPLE LA NORMA COMPLIES WITH THE STANDARDS
	MEDIDA DE LA RECTITUD DE LOS LADOS MEASUREMENT OF SIDE STRAIGHTNESS	DESVIACIÓN RESPECTO MEDIDA DE FABRICACIÓN: DEVIATION FROM MANUFACTURING MEASURE.	NO RECTIFICADOS: +5% MÁX 0,5MM NO RECTIFIED RECTIFICADOS: + 0,3 % MÁX 0,8MM RECTIFIED	DESVIACIÓN MÁXIMA MAXIMUM DEVIATION ±0,2%
	MEDIDA DE LA ORTOGONALIDAD SQUARENESS	DESVIACIÓN RESPECTO MEDIDA DE FABRICACIÓN: DEVIATION FROM MANUFACTURING MEASURE.	NO RECTIFICADOS: +5% MÁX 0,5MM NO RECTIFIED RECTIFICADOS: + 0,3 % MÁX 1,5MM RECTIFIED	DESVIACIÓN MÁXIMA MAXIMUM DEVIATION ±0,2%
 UNE-EN ISO 10545-3	MEDIDA DE LA PLANITUD DE LA SUPERFICIE LATERAL - CENTRAL - ALABEO -	DESVIACIÓN RESPECTO MEDIDA DE FABRICACIÓN: DEVIATION FROM MANUFACTURING MEASURE.	NO RECTIFICADOS: +5% MÁX 0,5MM NO RECTIFIED RECTIFICADOS: + 0,4 % MÁX 1,8MM RECTIFIED	DESVIACIÓN MÁXIMA MAXIMUM DEVIATION ±0,2%
	ABSORCIÓN DE AGUA WATER ABSORPTION	VALOR MEDIO ≤ 0,5 %		E ≤ 0,1 %
 UNE-EN ISO 10545-4	MÓDULO DE ROTURA MODULUS OF RUPTURE	≥ 35 N/mm <sup>2</sup>		> 40 N/mm <sup>2</sup>
	FUERZA DE ROTURA BREAKING STRENGTH	> 1.300 N		> 2.000 N
 UNE-EN ISO 10545-7	RESISTENCIA A LA ABRASIÓN RESISTANCE TO ABRASION	SEGÚN LOS VALORES DEL FABRICANTE AS PER MANUFACTURER		SEGÚN MODELOS
 UNE-EN ISO 10545-8	DETERMINACIÓN DE LA DILATACIÓN TÉRMICA LINEAL THERMAL EXPANSION COEFFICIENT	MÉTODO DE ENSAYO DISPONIBLE TEST METHOD AVAILABLE		<6,6 x 10 <sup>-6</sup> K <sup>-1</sup>
 UNE-EN ISO 10545-9	RESISTENCIA AL CHOQUE TÉRMICO RESISTANCE TO THERMAL SHOCK	MÉTODO DE ENSAYO DISPONIBLE TEST METHOD AVAILABLE		RESISTE RESISTS
 UNE-EN ISO 10545-11	RESISTENCIA AL CUARTEO BALDOSAS ESMALTADAS CRAZING RESISTANCE	EXIGIDO REQUIRED		CUMPLE LA NORMA COMPLIES WITH THE STANDARDS
 UNE-EN ISO 10545-12	RESISTENCIA A LA HELADA FROST RESISTANCE	EXIGIDO REQUIRED		CUMPLE LA NORMA COMPLIES WITH THE STANDARDS
 UNE-EN ISO 10545-13	RESISTENCIA A LOS ÁCIDOS Y BASES RESISTANCE AGAINST ACIDS AND BASES	SEGÚN LOS VALORES DEL FABRICANTE AS PER MANUFACTURER		CLASE B Min. CLASS B MIN.
	RESISTENCIA A LOS PRODUCTOS DE LIMPIEZA Y REACTIVOS DE PISCINA HOUSEHOLD DETERGENTS AND ADDITIVES FOR SWIMMING-POLS	CLASE B Min. CLASS B MIN.		CUMPLE LA NORMA COMPLIES WITH THE STANDARDS
 UNE-EN ISO 10545-14	RESISTENCIA A LAS MANCHAS RESISTENCE TO STAINING	MÍNIMO CLASE 3 CLASS 3 MINIMUM		CUMPLE LA NORMA COMPLIES WITH THE STANDARDS

US0 = Suelos y Paredes Interiores y Exteriores

\* Bia Absorción de agua < 0,5%



## INSTRUCCIONES DE MANTENIMIENTO / MAINTENANCE INSTRUCTIONS

### MATERIALES ANTIDESLIZANTES / NON-SLIP MATERIALS

#### 1. CONSIDERACIONES PREVIAS

Los materiales antideslizantes, debido a las características superficiales inherentes a los mismos (mayor superficie específica), resultan menos higiénicos (mayor facilidad para acumular suciedad y dificultad para eliminarla) que los modelos que no presentan esta propiedad.

La prescripción de este tipo de texturas se debe dirigir únicamente hacia aquellos ambientes que realmente lo requieran, ya sea por especificaciones legales ó normativas, o bien por el establecimiento de las condiciones de seguridad necesarias para minimizar el riesgo de caídas por resbalones en áreas concretas (piscinas, rampas, exteriores zonas húmedas, ...)

#### 2. DURANTE LA INSTALACIÓN

Con el objetivo de minimizar la deposición de restos de material de agarre y rejuntado sobre el pavimento cerámico se deben tomar una serie de precauciones que facilitarán la limpieza posterior y evitarán el empleo de métodos más agresivos de limpieza:

Adoptar las medidas constructivas y organizativas que sean necesarias para garantizar que las vías de acceso y circulación permanezcan todo lo secas que sea posible, evitando potenciales encharcamientos (pendientes, orificios de salida adecuados, desagües, ...).

Evitar el endurecimiento del material de agarre y rejuntado sobre la superficie antideslizante, eliminando cualquier resto de adhesivo cuando aún todavía no ha fraguado, utilizando para ello suficiente cantidad de agua. La operación de rejuntado se debe limitar a áreas pequeñas limpiando inmediatamente el material de la superficie cerámica. Se debe utilizar abundante agua limpia, asegurando que los restos de limpieza son eliminados de la superficie cerámica, evitando así que el material desprendido vuelva a quedar depositado sobre las baldosas. La rugosidad de la textura, así como la mayor superficie específica, son características que provocan que, una vez transcurrido el tiempo de maduración del material cementoso, resulte más compleja la operación de eliminación del mismo de la superficie.

Proteger el pavimento hasta la finalización de las reformas, para evitar daños y manchas provocados por las acciones posteriores a la colocación del pavimento y previas a la entrega de la obra.

#### 3. PROHIBICIONES / ACCIONES DESACONSEJADAS

No se emplearán productos ni métodos de limpieza agresivos, sobre todo limpieza con máquina rotativa con discos de PAD duro, ya que generan un pulido de la superficie y reducen gradualmente la resistencia al deslizamiento.

No se utilizarán espátulas metálicas ni estropajos abrasivos en su limpieza ni productos químicos concentrados.

#### 4. MANTENIMIENTO Y LIMPIEZAS PERIÓDICAS

Se recomienda la instalación de sistemas de retención de suciedad en los accesos, tipo alfombras ó felpudos, como medida preventiva para reducir la periodicidad de las operaciones de limpieza.

Existen varios sistemas que son adecuados para la limpieza de este tipo de superficies:

Equipos o sistemas de agua a presión.

Sistemas de aplicación de vapor

Cepillo de púas de plástico y aclarado con abundante agua

Se permite la máquina rotativa siempre que el útil de limpieza sea un cepillo de plástico.

Como producto de limpieza se puede utilizar cualquier desinfectante comercial, tipo lejía. Se deben evitar productos jabonosos o aquellos que contienen ceras en su composición, ya que pueden aumentar el riesgo de accidentes.

#### 5. CONCLUSIONES

Las características de las baldosas con textura antideslizante se ajustan al uso especificado en la ficha técnica de producto siempre que se hayan seguido las pautas de manipulación, colocación, mantenimiento (limpieza) y uso adecuadas.

Si el propietario incumple lo dispuesto en el presente manual, PORCELANOSA no se hará responsable de los hechos que se puedan derivar de dicho incumplimiento.

#### 1. INITIAL CONSIDERATIONS

Non-slip materials, due to their inherent surface characteristics (more specific surface,) are less hygienic (it is easier for dirt to accumulate and it is harder to remove it) than models that do not have this property.

The recommendation for of this type of texture shall be directed only towards those settings that really require it, either due to legal or regulation specifications, or the establishment of safety conditions necessary to minimize the risk of falls from slipping in specific areas (swimming pools, outdoor ramps, wet areas,...)

#### 2. DURING INSTALLATION

In order to minimize deposition of bonding and grouting material debris on the ceramic flooring, we shall take a series of precautions that will facilitate subsequent cleaning and will prevent the use of more aggressive cleaning methods:

Adopt the necessary construction and organizational measures to ensure that access and circulation routes remain as dry as possible, avoiding potential water logging (slopes, appropriate outlet openings, drains,...)

Avoid the hardening of the bonding and grouting material on the non-slip surface, eliminating any adhesive remaining while it has not yet set, using plenty of water to this end. The grouting operation shall be limited to small areas, cleaning the material immediately from the ceramic surface. Plenty of clean water shall be used, ensuring that the cleaning debris is eliminated from the ceramic surface, thus avoiding the detached material from depositing again on the tiles. The roughness of the texture, as well as a greater specific surface, are characteristics that cause that, once the cement material's setting time has passed, its surface removal operation is more complex.

Protect the flooring until the completion of the work, in order to avoid damage and stains caused by actions subsequent to the flooring installation and prior to the delivery of the work.

#### 3. PROHIBITIONS / ADVISED-AGAINST ACTIONS

No aggressive cleaning products or methods shall be used, specially cleaning with rotary machine with hard PAD discs, as they generate a polished surface and gradually reduce the slip resistance.

Metal spatulas, abrasive scourers, or concentrated chemicals shall not be used in cleaning.

#### 4. MAINTENANCE AND REGULAR CLEANING

We recommend installing dirt retention systems in the entries, such as rugs or doormats, as a preventive measure in order to reduce the frequency of cleaning operations.

There are several systems that are suitable for cleaning this type of surface:

Water pressure equipment or systems.

Steam application systems

Plastic bristle brush and rinsing with plenty of water

Rotary machine is allowed as long as the cleaning tool is a plastic brush.

Any commercial disinfectant such as bleach can be used as a cleaning product. Soapy products or those containing waxes in their composition shall be avoided, as they can increase the risk of accidents.

#### 5. CONCLUSIONS

The characteristics of tiles with non-slip texture conform to the use specified in the product's datasheet provided that the appropriate handling, installation, maintenance (cleaning) and use guidelines have been followed.

If the owner fails to comply with the provisions of this manual, PORCELANOSA shall not be liable for the incidents that may arise from this non-compliance.



## STON-KER® CARACTERÍSTICAS TÉCNICAS / TECHNICAL FEATURES

NORMA - STANDARD	ENSAYO - TEST	UNE EN 14411 : 2013 ISO 13006 : 2012	VALORES - VALUES
UNE-EN ISO 10545-2	MEDIDA DE LONGITUD Y ANCHURA LENGTH AND WIDTH	DESVIACIÓN RESPECTO MEDIDA DE FABRICACIÓN: DEVIATION FROM MANUFACTURING MEASURE.	NO RECTIFICADOS: +0,6% MÁX 2MM NO RECTIFIED RECTIFICADOS: + 0,3 % MÁX 1MM RECTIFIED  DESVIACIÓN MÁXIMA MAXIMUM DEVIATION ± 0,2%
	MEDIDA DEL GROSOR THICKNESS	DESVIACIÓN RESPECTO MEDIDA DE FABRICACIÓN: DEVIATION FROM MANUFACTURING MEASURE.	±5% MÁX 0,5MM  CUMPLE LA NORMA COMPLIES WITH THE STANDARDS
	MEDIDA DE LA RECTITUD DE LOS LADOS MEASUREMENT OF SIDE STRAIGHTNESS	DESVIACIÓN RESPECTO MEDIDA DE FABRICACIÓN: DEVIATION FROM MANUFACTURING MEASURE.	NO RECTIFICADOS: +5% MÁX 1,5MM NO RECTIFIED RECTIFICADOS: ± 0,3 % MÁX 0,8MM RECTIFIED  DESVIACIÓN MÁXIMA MAXIMUM DEVIATION ± 0,2%
	MEDIDA DE LA ORTOGONALIDAD SQUARENESS	DESVIACIÓN RESPECTO MEDIDA DE FABRICACIÓN: DEVIATION FROM MANUFACTURING MEASURE.	NO RECTIFICADOS: +5% MÁX 2MM NO RECTIFIED RECTIFICADOS: ± 0,3 % MÁX 1,5MM RECTIFIED  DESVIACIÓN MÁXIMA MAXIMUM DEVIATION ± 0,2%
	MEDIDA DE LA PLANITUD DE LA SUPERFICIE LATERAL - CENTRAL - ALABEO -	DESVIACIÓN RESPECTO MEDIDA DE FABRICACIÓN: DEVIATION FROM MANUFACTURING MEASURE.	NO RECTIFICADOS: +5% MÁX 2MM NO RECTIFIED RECTIFICADOS: ± 0,4 % MÁX 1,8MM RECTIFIED  DESVIACIÓN MÁXIMA MAXIMUM DEVIATION ± 0,2%
UNE-EN ISO 10545-3	ABSORCIÓN DE AGUA WATER ABSORPTION	VALOR MEDIO ≤ 0,5 %	E ≤ 0,1 %
UNE-EN ISO 10545-4	MÓDULO DE ROTURA MODULUS OF RUPTURE	≥ 35 N/mm <sup>2</sup>	> 42 N/mm <sup>2</sup>
	FUERZA DE ROTURA BREAKING STRENGTH	> 1.300 N	> 2.100 N
UNE-EN ISO 10545-7	RESISTENCIA A LA ABRASIÓN RESISTANCE TO ABRASION	SEGÚN LOS VALORES DEL FABRICANTE AS PER MANUFACTURER	SEGÚN MODELOS
UNE-EN ISO 10545-8	DETERMINACIÓN DE LA DILATACIÓN TÉRMICA LINEAL THERMAL EXPANSION COEFFICIENT	MÉTODO DE ENSAYO DISPONIBLE TEST METHOD AVAILABLE	<6,6 x 10 <sup>-4</sup> K <sup>-1</sup>
UNE-EN ISO 10545-9	RESISTENCIA AL CHOQUE TÉRMICO RESISTANCE TO THERMAL SHOCK	MÉTODO DE ENSAYO DISPONIBLE TEST METHOD AVAILABLE	RESISTE RESISTS
UNE-EN ISO 10545-11	RESISTENCIA AL CUARTEO BALDOSAS ESMALTADAS CRAZING RESISTANCE	EXIGIDO REQUIRED	CUMPLE LA NORMA COMPLIES WITH THE STANDARDS
UNE-EN ISO 10545-12	RESISTENCIA A LA HELADA FROST RESISTANCE	EXIGIDO REQUIRED	CUMPLE LA NORMA COMPLIES WITH THE STANDARDS
UNE-EN ISO 10545-13	RESISTENCIA A LOS ÁCIDOS Y BASES RESISTANCE AGAINST ACIDS AND BASES	SEGUN LOS VALORES DEL FABRICANTE AS PER MANUFACTURER	CLASE B MIN. CLASS B MIN.
	RESISTENCIA A LOS PRODUCTOS DE LIMPIEZA Y REACTIVOS DE PISCINA HOUSEHOLD DETERGENTS AND ADDITIVES FOR SWIMMING-POLS	CLASE B MIN. CLASS B MIN.	CUMPLE LA NORMA COMPLIES WITH THE STANDARDS
UNE-EN ISO 10545-14	RESISTENCIA A LAS MANCHAS RESISTENCE TO STAINING	MÍNIMO CLASE 3 CLASS 3 MINIMUM	CUMPLE LA NORMA COMPLIES WITH THE STANDARDS

ISO = Suelos y Paredes Interiores y Exteriores

\* Bla Absorción de agua &lt; 0,5%



## RESISTENCIA AL DESLIZAMIENTO SEGÚN NORMA DIN 51130 SLIP RESISTANCE ACCORDING TO STANDARD DIN 51130

[ R9 ] [ R10 ] [ R11 ] [ R12 ] [ R13 ]

Muchos fabricantes europeos de suelos, usan ensayos del tipo de la rampa para clasificar sus productos en función del grado de deslizamiento.

Estos ensayos se llevan a cabo generalmente, usando la norma alemana DIN 51130. El método implica el uso de sujetos que caminan adelante y atrás a través de un suelo impregnado y utilizado como banco de ensayos en forma de rampa. El grado de inclinación de la rampa se va incrementando gradualmente hasta que el sujeto que está ensayando, resbala. El ángulo medio de inclinación al que el sujeto resbala, es utilizado para calcular el CoF (Coeficiente de fricción).

La norma DIN 51130 utiliza unas botas de seguridad según norma EN 345 y aceite de motor como sustancia que impregne la superficie a ensayar.

Many European flooring manufacturers use tests like the ramp test to rate their products according to their slip resistance. These tests are generally conducted using the German standard, DIN 51130. With this method, a person walks backwards and forwards on an impregnated ramp-type floor used as a test bench. The angle of the ramp is gradually increased until the person slips. The average angle at which the person slips is used to calculate the CoF (coefficient of friction).

DIN 51130 uses approved safety boots according to standard EN 345 and engine oil to impregnate the test surface.

### MÉTODO DE LA RAMPA (DIN 51130) RAMP METHOD

VALOR TOTAL MEDIO DEL ÁNGULO DE CAIDA  
TOTAL MEAN VALUE OF SLIP ANGLE

60° ≤ Ángulo ≤ 102°  
100° < Ángulo ≤ 192°  
190° < Ángulo ≤ 272°  
270° < Ángulo ≤ 352°  
350° ≤ Ángulo

GRUPO DE CLASIFICACIÓN  
RATING

R9  
R10  
R11  
R12  
R13

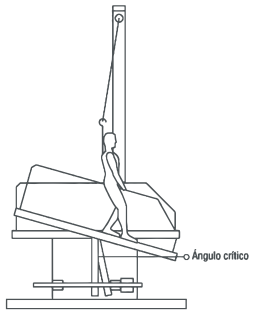

### TABLA DE VALORACIÓN DE RIESGO DE DESLIZAMIENTO SLIP RISK ASSESSMENT TABLE

#### LOCALES Y ÁREAS DE TRABAJO PREMISES AND WORK AREAS

LOCALES Y ÁREAS DE TRABAJO GENERALES GENERAL TYPES OF PREMISES AND WORK AREAS

Entradas Entrances (\*)

Escaleras Stairs (\*\*)

Espacios comunes (lavabos, lavaderos, etc) Communal areas (toilets, laundries etc)

Salas de reunión Meeting rooms

Sanitaria Areas for health-related use

COCINAS, COMEDORES KITCHENS, DINING ROOMS

Cocinas gastronómicas (restaurantes y hoteles) Hospitality-industry kitchens (restaurants and hotels)

Hasta 100 cubiertos por día Up to 100 diners a day

Más de 100 cubiertos por día Over 100 diners a day

Cocinas cooperativas en residencias, colegios, sanatorios Cooperative-type kitchens in residences, schools or nursing homes

Cocinas cooperativas en hospitales y clínicas Cooperative-type kitchens in hospitals and clinics

Grandes cocinas cooperativas en ferias, cantinas y móviles Large cooperative-type kitchens at trade fairs and in canteens and mobile kitchens

Cocinas para comida rápida Fast-food kitchens

Cocinas para calentado de comidas preparadas Kitchens for heating up precooked food

Salas de café y te Tearooms and coffee shops

Comedores, salas de clientes, cantinas incluidos pasillos de servicio Dining rooms, client rooms, and canteens including corridors leading to them

LOCALES DE LOS SERVICIOS SANITARIOS FACILITIES USED FOR HEALTH SERVICES

Baños termales, hidroterapia y fangos Thermal spas, and hydrotherapy and mud-treatment facilities

Zonas de baño Bathing areas

Zonas sanitarias, estaciones de baño Health facilities, spas

Zonas de diagnóstico médico y terapéutico, salas de masaje Areas for medical diagnostic and therapeutic purposes, and massage rooms

Plantas con habitaciones de enfermos y pasillos Floors containing rooms for patients and corridors

Consultorios médicos, ambulatorios Medical surgeries and outpatient clinics

Farmacias Chemist's

Laboratorios Laboratories

GARAJES GARAGES

Garajes, (en edificio o subterráneos) sin influencia climática Garages (indoor or underground), unaffected by the climate

Parking al aire libre Open-air car parks

COLEGIOS Y GUARDERÍAS SCHOOLS AND NURSERY SCHOOLS

Entradas, pasillos, zonas de descanso Entrances, corridors, rest areas

Aulas, salas para grupos Classrooms, rooms for groups

Escaleras Stairs

Lavabos Toilets

Zonas de tránsito exteriores Outdoor transit areas

(\*) Las entradas se refieren a aquellas zonas a las que se puede acceder directamente desde el exterior y en donde la humedad puede llegar o ser introducida desde el exterior.

(\*\*) Las escaleras se refieren únicamente a aquellas a las que puede llegar o ser introducida la humedad desde el exterior, como las situadas directamente a continuación de las entradas con acceso desde el exterior.

(\*) Entrances refer to places with direct access from the outside of the building where wetness might be brought inside.

(\*\*) Stairs only refer to ones where wetness might be brought inside from outside the building or ones located directly after entrances with direct access from the outside.





## CTE. CÓDIGO TÉCNICO DE LA EDIFICACIÓN / SPANISH BUILDING CODE

El CTE, Código Técnico de la Edificación, dentro de su Documento Básico de seguridad de Utilización 1 "DB SU 1 - seguridad frente al riesgo de caídas", define los requisitos que debe cumplir un suelo para poder ser utilizado como pavimento de los edificios o zonas de uso sanitario, docente, comercial, administrativo, aparcamiento y pública concurrencia (excluidas las zonas de uso restringido). Para ello, el pavimento deberá cumplir con un valor mínimo al deslizamiento "Rd".





El valor de resistencia al deslizamiento "Rd", se determina mediante el ensayo del péndulo descrito en el Anexo A de la norma UNE-ENV 12633: 2003.

*"Safety of Use" Basic Document 1 ("DB SU 1 – Preventing Falls") of the Spanish Building Code (the CTE in Spanish) defines the requirements that a floor covering must meet in buildings or areas used for health-related, educational, commercial, administrative or public purposes or for parking (excluding areas of restricted use). To comply, the flooring must achieve a minimum slip resistance (Rd) value.*

*The slip resistance (Rd) value is determined using the pendulum test described in Appendix A of standard UNE-ENV 12633: 2003.*

La siguiente tabla establece la clasificación de los suelos según su resbaladidad:

The following table shows the rating system for flooring, depending on its slip resistance:

RESISTENCIA AL DESLIZAMIENTO RD <i>SLIP RESISTANCE RD</i>	CLASE <i>CLASS</i>				
Rd < 15	0				
15 < Rd < 35	1				
35 < Rd < 45	2				
Rd > 45	3				

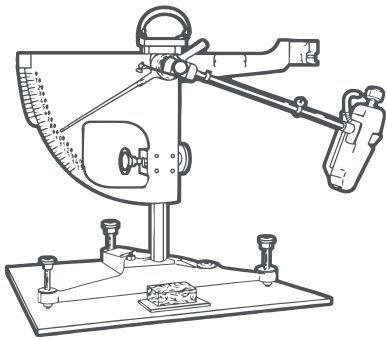

CLASE EXIGIBLE A LOS SUELOS EN FUNCIÓN DE SU LOCALIZACIÓN RATING REQUIRED FOR FLOORING DEPENDING ON ITS LOCATION

LOCALIZACIÓN Y CARACTERÍSTICAS DE SUELO LOCATION AND CHARACTERISTICS OF THE FLOOR	CLASE CLASS
ZONAS INTERIORES SECAS DRY INDOOR AREAS: Superficies con pendiente menor que el 6% Surfaces with a slope of less than 6% Superficies con pendiente igual o mayor que el 6% y escaleras Surfaces with a slope equal to or higher than 6% and stairs	1 2
ZONAS INTERIORES HÚMEDAS, TALES COMO LAS ENTRADAS A LOS EDIFICIOS DESDE EL ESPACIO EXTERIOR (1), TERRAZAS CUBIERTAS, VESTUARIOS, BAÑOS, ASEOS, COCINAS, ETC. : INDOOR AREAS SUBJECT TO MOISTURE, SUCH AS ENTRANCES TO BUILDINGS FROM OUTDOOR AREAS (1), COVERED TERRACES AND BALCONIES, CHANGING ROOMS, BATHROOMS, CLOAKROOMS, KITCHENS ETC: Superficies con pendiente menor que el 6% Surfaces with a slope of less than 6% Superficies con pendiente igual o mayor que el 6% y escaleras Surfaces with a slope equal to or higher than 6% and stairs	2 3
ZONAS EXTERIORES. PISCINAS. DUCHAS (2) OUTDOOR AREAS. SWIMMING POOLS. SHOWERS (2)	3

(1) Excepto cuando se trate de accesos directos a zonas de uso restringido (1) Except for accesses that lead directly to areas of restricted us

(2) En zonas previstas para usuarios descalzos y en el fondo de los vasos, en las zonas en las que la profundidad no exceda de 1.50 m. (2) In places where users are expected to go barefoot and in the bottom of swimming pools in areas with a depth of less than 1.50 m.

Dicha clase se mantendrá durante la vida útil del pavimento This rating is maintained throughout the useful life of the flooring.

RESISTENCIA AL DESLIZAMIENTO, COEFICIENTE DE FRICCIÓN DINÁMICO (DCOF) //SLIP RESISTANCE, DYNAMIC COEFFICIENT OF FRICTION

LA VALORACIÓN DE LA PRESTACIÓN ANTIDESLIZANTE EN EL MERCADO AMERICANO SE LLEVA A CABO A TRAVÉS DE UN ROBOT MÓVIL (BOT 3000). ESTE EQUIPO CIRCUA SOBRE LA SUPERFICIE A TESTAR (PREVIAMENTE MOJADA) Y DETERMINA LA RESISTENCIA DE LA MISMA AL MOVIMIENTO DEL EQUIPO.

LA NORMATIVA EN ESTADOS UNIDOS (NORMA ANSI) REQUIERE UN VALOR DCOF ≥ 0.42 PARA SUPERFICIES SUSCEPTIBLES DE ESTAR MOJADAS.





*IN THE AMERICAN MARKET, THE ASSESSMENT OF THE ANTI-SLIP PERFORMANCE IS CARRIED OUT THROUGH A MOBILE ROBOT (BOT 3000). THIS UNIT TRAVELS ON THE SURFACE BEING TESTED (WETTED PREVIOUSLY) AND DETERMINES ITS RESISTANCE IN RESPONSE TO THE UNIT'S MOVEMENT.*

*THE EEUU STANDARDS (ANSI STANDARD) REQUIERE A DCOF VALUE ≥ 0.42 FOR SURFACES WHICH ARE SUSCEPTIBLE OF GETTING WET.*

### IMPORTANTE *IMPORTANT*

EL ACABADO ANTIDESLIZANTE (ANTISLIP) Ó CLASE 3 SE CONSIGUE UTILIZANDO 2 TECNOLOGÍAS

*THE NON-SLIP (ANTISLIP) OR CLASS 3 FINISH IS ACHIEVED USING 2 POSSIBLE TECHNOLOGIES*

		NANO-KER: Acabado mas suave, de fácil limpieza. Uso recomendado: viviendas unifamiliares excepto piscinas. <i>NANO-KER: A smoother, easier-to-clean finish. Recommended use: single-family homes, except swimming pools.</i>
		GRANILLA TÉCNICA: Acabado mas rugoso. Uso recomendado: piscinas, pavimentación urbana y de uso público en exteriores. <i>HIGH-PERFORMANCE POWDERED GLAZE: A rougher finish. Recommended use: swimming pools, urban paving, and outdoor public paved areas.</i>

## TIENDAS / SHOWROOMS

ESPAÑA - ANDORRA

PORTUGAL - GIBRALTAR

#### A CORUÑA

A CORUÑA\_SUMINISTROS VIA-MAR, S.L. · Médico Rodríguez, 18-20. +34 981 279 431 +34 981 279 431

A CORUÑA\_BETANZOS SUMINISTROS VIA-MAR, S.L. · Avda. Fraga Iribarne, s/n. +34 981 772 190 +34 981 774 257

CARBALLO\_JESUS PEDROUZO S.L. · Valle Inclán 24, Bajo. +34 981 701 120

CARNOTA\_CAPELO GARCIA, MANUEL FELIPE · LG San Mamed, s/n. +34 981 857 081

CEE\_B. FANDIÑO LADO, S.L. · CL. Valdepeñas, s/n. +34 981 748 003 +34 981 748 004

FERROL\_NEIRA Y ORTEGAL, S.L. · Carretera Catabois, 258. +34 981 326 532 +34 981 324 951

MUROS\_ALMACENES CASTILLO DE MUROS, S.L. · Rosalía de Castro, 5. Pol. Ind. Muros +34 981 826 368 +34 981 826 342

ORTIGUEIRA\_NEIRA Y ORTEGAL, S.L. · Carretera C-642 s/n, Cuiña. +34 981 400 880 +34 981 400 883

PUEBLA DEL CARAMIÑAL\_PEREZ DOMINGUEZ PUEBLA, S.L. · Angustia, 30. +34 981 830 214 +34 981 107 219

SANTA COMBA\_ALMACENES SEROMAVI, S.L. · Avda. Santiago, 18. +34 981 880 104 +34 981 818 617

SANTIAGO DE COMPOSTELA\_PORCELANOSA · General Pardiñas, 13-Bajo. +34 981 569 230 +34 981 563 830

SANTIAGO DE COMPOSTELA\_PORCELANOSA · Rua Clara Campoamor, 13-15 (Montouto). +34 981 509 270 +34 981 819 334

SANTIAGO DE COMPOSTELA\_PORCELANOSA · Poligono Comercial Costa Vella. +34 981 897 595 +34 981 530 901

#### ÁLAVA

VITORIA-GASTEIZ\_JORGE FERNÁNDEZ · Poligono de Jundiz. Paduleta, 53. +34 945 244 250 +34 945 229 321

VITORIA-GASTEIZ\_JORGE FERNÁNDEZ · Los Herrán, 30. +34 945 254 755 +34 945 259 668

#### ALBACETE

ALBACETE\_PORCELANOSA · Avda. Gregorio Arcos, 32. (Pol. Campollano). +34 967 243 658 +34 967 193 465

VILLARROBLEDO\_OLIVARES MAT. CONSTRUCCIÓN · Avda. Reyes Católicos, 168. +34 967 138 105 +34 967 138 023

#### ALICANTE

ALCOY\_SANEAMIENTOS COLON · Avda. de la Alameda, 10. +34 965 331 891 +34 965 524 210

ALTEA\_ELDECO · Carretera N-332 Partida Cap Blanch, 38A. +34 966 874 360 +34 966 873 543

BENISSA\_HIJOS DE JUAN RIBES · Avda. de la Estación, 2. +34 965 730 419

BENIDORM\_PORCELANOSA · Avda. Finestrat, 11, Local 8.

ELCHE\_PORCELANOSA · Avda. Alicante, 105. +34 966 610 676 +34 966 610 700

JÁVEA\_AZULEJOS JAVEA · Liverpool, 4. +34 965 791 036

ORIHUELA\_PORCELANOSA ORIHUELA COSTA · C. Comercial Cabo Roig. +34 647 653 892

SAN JUAN\_PORCELANOSA · Carretera Valencia, km 88. +34 965 656 200 +34 965 655 644

#### ALMERÍA

VÍCAR\_PORCELANOSA · Parque Comercial Viapark, Parcela 1. +34 950 325 575 +34 950 338 651

#### ASTURIAS

GIJÓN\_PORCELANORTE · S.L. Menéndez Pelayo 30. +34 984 396 462

OVIEDO\_PORCELANOSA · Pol. Espíritu Santo. Calle Dinamarca, s/n. +34 985 791 526 +34 985 985 963

#### ÁVILA

ÁVILA\_PAVIMARSA · Pol. Ind. Vicolozano · Parcela 2. +34 920 259 820 +34 920 259 821

#### BADAJOZ

MÉRIDA\_PORCELANOSA · Avda. Reina Sofía, 8. +34 924 330 218 +34 924 330 315

ZAFRA\_MUNDO OBRAS · Pol. Ind. Los Caños, Calle Bodión, 27. +34 924 551 264 +34 924 551 264

#### BALEARES

CALA D'OR · MALLORCA\_MACODOR · Carretera Calonge · Cala d'Or, km 1,5. +34 971 658 210

LLUCMAJOR · MALLORCA\_MAGATZEM SES FORQUES · Calle Doctor Fleming, 10. +34 971 662 114 +34 971 662 816

MANACOR · MALLORCA\_MATERIALES DE CONSTRUCCION GALMES SA · Carrer Via Palma, 67. +34 971 553 050

MAHÓN\_A PALLISER SL · Avda. Cap de Cavallería, 1. +34 971 3573 00 +34 971 357 400

PALMA DE MALLORCA\_PORCELANOSA · Gran Via Asima, 21. Pol. Son Castelló. +34 971 430 667 +34 971 297 094

SANT ANTONI DE PORTMANY\_IBIZA PORCELANOSA · Avda. Llauradors, 7. Pol. Montecristo. +34 971 317 292 +34 971 317 293

SOLLER\_CAN SOLER · Del Mar, 193. +34 971 630 219 +34 971 632 311

#### BARCELONA

BARCELONA\_AZULEJOS SAN ANDRÉS · Plaça Mossen Clapes, 2-3. +34 933 455 102 +34 933 461 015

CABRERA DE MAR\_ORMAT · Carretera de Vilassar-Argentona km.1. +34 937 591 139 +34 937 502 076

CALAF\_PLANELL · Carretera Manresa km 31. +34 938 698 750 +34 938 600 181

CANOVELLES\_COMERCIAL MAESTRO CANET · Pol. Can Castells, Nau 7-8. +34 938 466 568 +34 938 409 216

CASSERES\_MATERIALS CASSERRE · San Rafael. +34 938 213 770

CORNELLÀ\_LOFT CUINA · Carrer La Miranda, 6-8. +34 934 743 793 +34 934 741 305

GIRONELLA\_ANTONI PONT · Carrer Farguell, 31. +34 938 228 088 +34 938 250 786

L'HOSPITALET DE LLOBREGAT\_PORCELANOSA · Ciències, 65. Gran Via l'Hospitalet. +34 932 642 500 +34 932 007 036

MATARÓ\_MARESME GRES · Carrer Sant Isidor, 78. +34 931 615 015

MATARÓ\_ROSA JORDANA RABETLLAT · Carrer de Montserrat, 7. +34 937 903 089 +34 937 903 089

PALAU SOLITA I PLEGAMANS\_COMERCIAL SOLSAN · Cami Reial, 109. +34 938 648 125 +34 938 649 617

PINEDA DE MAR\_AMARGANT · Carrer Santiago Rusiñol, 96. +34 937 671 416 +34 937 627 488

SANT BOI DE LLOBREGAT\_GARRO · Carretera Sta. Creu de Calafell, km 10,7. +34 936 545 952 +34 938 400 620

SANT POL DE MAR\_AMARGANT · Passeig Parc, 1. +34 937 600 112 +34 937 600 411

SANT PERE DE RIBES\_SUMCO · Carretera de Barcelona, C-246 km 42,4. +34 938 933 066 +34 938 936 004

TARADELL\_JODUL · Carretera de Vic, km 5,8. +34 938 800 800 +34 938 126 054

TIANA\_BADALONA GRES · Carretera B-500, km 3,2. +34 933 950 311 +34 934 650 758

TORRELLÓ\_ARQUIMATT MATERIALS I DECORACIÓ · Carrer Sant Jordi, 16. +34 679 531 877

VIC\_CORRETTJA · Carrer Mas de Bigas, 8-26. +34 938 854 261 +34 938 894 733

VILAFRANCA DEL PENEDES\_FERRET I CASULLERAS · Carrer Sant Martí, 2. +34 93 890 14 19 - +34 93 817 03 53

VILANOVA DEL CAMÍ\_PLANELL · Carretera Vilafranca 108-111. +34 938 060 240 +34 938 060 239

#### BURGOS

ARANDA DEL DUERO\_JUAN GIL MOLINERO · Calle Padilla, 5. +34 947 501 049

BURGOS\_BIGMAT FONTECHA · Alcalde Martin Cobos,15. Nave 5 y 6. +34 947 485 153 +34 947 483 941

MIRANDA DE EBRO\_JORGE FERNÁNDEZ · Camino Fuente Basilio, s/n. +34 947 323 351 +34 947 314 559

#### CÁCERES

CÁCERES\_PORCELANOSA · Avda. Juan Pablo II, 130. +34 927 236 337 +34 927 236 205

#### CÁDIZ

ALGECIRAS\_PORCELANOSA · Carretera de Málaga, km 109. +34 956 635 282 +34 956 635 285

EL PUERTO DE SANTA MARÍA\_PORCELANOSA · Pol. El Palmer. Ctra. Madrid-Cádiz, km 653,2. +34 956 540 084 +34 956 872 464

JEREZ DE LA FRONTERA\_PORCELANOSA · Parque Empresarial, Avda. de la Ilustración, 1. +34 956 187 160 +34 956 302 904

SAN FERNANDO\_PORCELANOSA · Poligono Tres Caminos, s/n. +34 956 592 360 +34 956 884 677

#### CANTABRIA

SANTANDER\_PORCELANOSA · Avda. Parayas, s/n. +34 942 352 510 +34 942 352 638

#### CASTELLÓN

CASTELLÓN\_PORCELANOSA · Parque Comercial Estepark / Av. E.Gimeno s/n. +34 964 506 800 +34 964 525 418

VINAROZ\_PORCELANOSA · Carretera N-340, km 1.050,1. +34 964 400 944 +34 964 400 650

#### CEUTA

CEUTA\_BAEZA · Ampliación Muelle de Poniente, 96. +34 956 511 312 +34 956 511 309

#### CIUDAD REAL

CIUDAD REAL\_PORCELANOSA · Carretera de Carrión, 11. +34 926 251 730 +34 926 255 741

LA SOLANA\_LOS PEPOTES · Calle Emilio Nieto, 39. +34 926 63 15 80 +34 926 63 38 56

#### CÓRDOBA

CÓRDOBA\_PORCELANOSA · Carretera N-IV, km 404. Pol. de Torrecilla. +34 957 760 024 +34 957 760 123

#### CUENCA

CASAS DE HARO\_MATERIALES DE CONSTRUCCIÓN MARTÍNEZ ORTEGA · Calle Dos de Mayo, 28. +34 969 380 708 +34 969 380 708

CUENCA\_VICOSAZ · Hermanos BecerriI, 6 bajo. +34 969 233 200 +34 969 234 475

HONRUBIA\_JUAN MANUEL MUÑOZ FERNÁNDEZ · Calle de la Feria, 29. +34 969 292 044

TARANCÓN\_VICENTE DE LOS RIOS · Avda. del Progreso, 19. +34 969 321 323 +34 969 321 334

VILLANUEVA DE LA JARA\_ALMACENES PAÑOS · Camino de Rubielos, 8. +34 967 498 000 +34 967 498 000

#### GERONA

ARBUCIES\_ARC ARBUICIES CERAMIQUES · Pol. Ind. Cal Xic-Parc, 4. +34 972 162 364 +34 972 860 954

BLANES\_BRECOR SL · Carretera Tordera,79. +34 972 336 062 +34 972 358 482

CORNELLÀ DEL TERRI\_OLIVERAS · Carretera de Girona a Banyoles km 12,8. +34 972 594 131 +34 972 594 552

ESCLANYÀ BEGUR\_MATERIALES CREXELL · Carrer Palàfrugell Regencos. Pol. industrial Riera Esclanya, 1. +34 972 300 628 +34 972 610 772

FIGUERES\_OLIVERAS · Carretera N-11 km 759. +34 972 672 259 +34 972 672 255

GIRONA\_PORCELANOSA · Carretera Barcelona 120-122-124. +34 972 964 141

LES PRESSES\_OLIVERAS · Pol. Ind. Les Presstes. Parcel·la 20. +34 972 694 704 +34 972 693 003

LLORET DE MAR\_CARMONA · Carretera de Lloret\_Vidreres 2,1. +34 972 372 710 +34 972 349 763

MONT-RAS\_MERCAMAT · Carretera C-31 km. 329,8. +34 972 612 027 +34 972 302 146

PALOL D'ONYAR-QUART\_OLIVERAS · Carretera Comarcal C-250 km 4,3. +34 972 468 119 +34 972 468 123

SANT FELIU DE GUIXOLS\_GINESTA · Carrer Santa Magdalena, 11. +34 972 320 529 +34 972 321 616

VILA-SACRA\_FRIAS MATERIALS · Carrer Castelló, 72. +34 972 670 073 +34 972 673 071

#### GRANADA

ARMILLA\_TECMACER · Avda. San Rafael (Junto Sprinter). +34 958 253 081 +34 958 183 367

#### GUIPÚZCOA

SAN SEBASTIÁN\_JORGE FERNÁNDEZ · Pol. Ind. Belartzta. Fernando Múgica, 15. +34 943 376 966 +34 943 376 841

#### HUELVA

HUELVA\_PORCELANOSA · Poligono La Paz Naves 1-5. +34 959 543 600 +34 959 237 951

#### HUESCA</

### LÉRIDA

BALAGUER\_ J. FARRÉ · Carrer Urgell, 39. +34 973 445 765 +34 973 445 072
EL PONT DE SUERT\_PRETENSADOS RIBERA · Carretera N-230 km 124,5. +34 973 690 063 +34 973 690 400
LA SEU D'URGELL\_MATERIALS PIRINEU · Carretera de Lleida, 28. +34 973 351 850 +34 973 353 410
LLEIDA\_MATERIALS GERMANS MAURI · Carrer Princep de Viana, 36. +34 973 232 139 +34 973 247 943
LLEIDA\_PROMOCIÓIN DE PREFABRICADOS SL PMP · Ivars d'Urgell, 20. P.Ind Neoparc. +34 973 603 954 +34 973 603 950
LLEIDA\_PUJOL ELEMENTS · Carrer Tarragona, 40. +34 973 202 350 +34 973 203 113
MOLLERUSA\_VISAMAT · Avda. del Canal, 84 Baixos. +34 973 801 035
SOLSONA\_MATERIALS JORDI VILAR · Carretera Manresa, s/n km.50. +34 973 482 077 +34 973 482 373
TARREGA\_NOUMAG · Júpiter, 7 (Pol. Ind. La Canaleta). +34 607 497 330
VIELHA\_PRETENSADOS RIBERA · Carretera França, 40. (Mig Aran). +34 973 641 460 +34 973 642 271

### LUGO

CHANTADA\_SONIA GÓMEZ GÓMEZ · Juan XXIII, Bajo 22. +34 982 441 249 +34 982 440 331
FOZ\_ALMACENES BAHIA, S.L. · Maestro Lugilde, 6. +34 982 140 957 +34 982 132 065
LUGO\_ARIAS NADELA, S.L. · Tolda de Castilla, s/n. +34 982 245 725 +34 971 662 816
LUGO\_ARIAS NADELA, S.L. · Crta. N-VI, Km. 498 (Pol. Do Ceao). +34 982 221 254
XOVE\_ESTABLECIMIENTOS REY, S.L. · Avda. Diputación, 88. +34 982 592 006 +34 982 592 071

### MADRID

ALCORCÓN\_PORCELANOSA · Carretera N-V, km 15,5. Parque Oeste de Alcorcón. +34 916 890 172 +34 916 890 170
LEGANÉS\_PORCELANOSA · Avda. Recomba, 13. Polígono la Laguna Salida 53 - M50. +34 914 819 200 +34 916 930 292
MADRID\_EL CORTE INGLÉS CASTELLANA · Paseo de la Castellana, 85. +34 671 708 692
MADRID\_PORCELANOSA · Ortega y Gasset, 62. Esquina Conde Peñalver. +34 914 448 460 +34 914 025 111
MADRID\_PORCELANOSA · Alcalá, 514. +34 917 545 161 +34 917 545 555
SAN SEBASTIÁN DE LOS REYES\_PORCELANOSA · Plaza del Comercio, 17. +34 916 623 232

### MÁLAGA

MÁLAGA\_PORCELANOSA · Victoria de los Angeles, 1. +34 952 241 375 +34 952 240 092
MARBELLA\_PORCELANOSA · Ricardo Soriano, 65. +34 952 826 868 +34 952 822 880
NERJA\_PAVISER NERJA, S.L. · Pol. Pto. Limpio Maz, 3, Parcela 12. +34 952 524 223 +34 952 524 223
VÉLEZ-MÁLAGA\_MATERIALES MUÑOZ PÉREZ SL · Ferrocarril, 2. +34 952 507 879 +34 952 504 760

### MELILLA

MELILLA\_FERRETERIA MODERNA E HIJOS, S.L. · Paseo Marítimo Mir Berlanga, 19. +34 952 671 144 +34 952 691 285

### MURCIA

MURCIA\_PORCELANOSA · Avda. Juan de Borbón, s/n. Parque Comercial Thader. +34 968 879 527 +34 968 831 725

### NAVARRA

CINTRUÉNIGO\_CERÁMICAS CECILIO CHIVITE · Pol. Ind. s/n. Variante N-113. +34 948 811 973 +34 948 815 249
NAVARRA\_MULTIVA BAJA\_MONTEJO CERÁMICAS · Pol. Carretera Tajonar, Calle-A, Naves 2- 4. +34 948 239 065 +34 948 230 503
PAMPLONA\_MONTEJO CERÁMICAS· Navas de Tolosa, s/n. +34 948 224 000 +34 948 226 424
TUDELA\_MONTEJO CERÁMICAS· Carretera Tudela -Tarazona, Pol. Centro de Servicios de Tudela. +34 948 848 365 +34 948 848 573

### ORENSE

CARBALLIÑO\_JOSE R. PITEIRA, S.L. · Avda. Julio Rodríguez Soto, 63. +34 988 271 071 +34 988 274 780
OURENSE\_BLANCO QUINTAS, S.A. · Avda. Otero Pedrayo, 8. +34 988 391 478
VERIN\_MATERIALES DE CONSTRUCCION ER-CA, S.L. · Avda. de Portugal, 44. +34 988 411 030 +34 988 411 081

### PALENCIA

PALENCIA\_CANTALAPIEDRA · La Puebla, 2. +34 979 706 421 +34 979 702 652

### PONTEVEDRA

A ESTRADA\_DALARJO, S.L. CL · Alto de la Cruz , s/n. +34 986 570 489 +34 986 570 610
DENA - MEAÑO\_PREFABRICADOS DENA, S.L. · Rúa de Galicia, 24. +34 986 743 121 +34 986 745 131
LALÍN\_ALMACENES CANDA, S.L. · Monserrat, 36-39. +34 986 780 184 +34 986 782 301
O GROVE\_PREFABRICADOS DENA, S.L. · Alexandre Boveda, 82. +34 986 702 041 +34 986 733 415
SEIXO, MARÍN\_SANEAMIENTOS ROSALES, S.L. · Avda. Doctor Otero Ulloa, 1. +34 986 702 041 +34 986 702 080
SILLEDA\_ARCOLAR 2000, S.L. · Rúa de Venezuela, 40. +34 986 580 114 +34 986 592 513
VIGO\_SANEAMIENTOS ROSALES, S.L. · García Barbón, 139 B. +34 986 228 806
VILAGARCIA DE AROUSA\_SANEAMIENTOS GANDARA · Avda. La Marina, 126-128 Bajo. +34 986 506 640 +34 986 512 606

### SALAMANCA

VILLARES DE LA REINA\_PORCELANOSA · Pol. Villares. Carretera Salamanca - Valladolid, km 2,2. +34 923 243 811 +34 923 123 414

### SEGOVIA

EL ESPINAR\_SEGOCER · Carretera Madrid - La Coruña, km 64. +34 921 172 426 +34 921 171 828
SEGOVIA\_SEGOCER · José Zorrilla, 134. +34 921 444 122

### SEVILLA

ESTEPA\_MATAS INTERIORISMO SL · Avda. Andalucía. Salida Málaga. +34 955 915 937 +34 955 915 938
LORA DEL RÍO\_HERNÁNDEZ CARBALLO · Betis s/n. +34 955 800 473 +34 955 801 439
SEVILLA\_PORCELANOSA · Tipografía, s/n. Pol. Industrial La Negrilla. (A-92 dirección Granada) +34 954 260 540 +34 954 528 681
TÓMARES\_PORCELANOSA · San Roque, s/n. Polígono El Manchón. +34 954 152 792 +34 954 153 188

### SORIA

SORIA\_MC ODORICIO · Polígono las Casas-II. Calles A y J, Parcela 201. +34 975 233 228 +34 975 232 188

### STA. CRUZ DE TENERIFE

STA. CRUZ DE TENERIFE\_PORCELANAS Y PAVIMENTOS CANARIOS · Avda. 3 de Mayo, 18. +34 922 209 595 +34 922 209 596

### TARRAGONA

ALCOVER\_EXPOMAT ALCOVER · Tramuntana, s/n. (Polígono Roques Roges) +34 977 760 476
EL VENDRELL\_MAUJA · Carrer Terrissaires, 1. +34 977 661 951
MORA LA NOVA\_COMERCIAL LLAURADO · Carretera de Tivissa, s/n. +34 977 400 387 +34 977 400 052
REUS\_MAUJA · PLAÇA DE LES OQUES, 8. +34 977 312 502 +34 977 317 211
RODA DE BARA\_CONSTRUCCIONS CIURO · Acceso a Roda de Bara km 1. +34 977 802 951 +34 977 802 012
TARRAGONA\_TINALEX ARTE · Carretera Valencia, 202. + 34 977 551 055
TARRAGONA\_TINALEX ARTE · Carretera Pont d'Armentera, 1. +34 977 221 901
VALLS\_RAMON MAGRIÑA BATALLA · Carrer Montblac, 14. +34 977 600 210 +34 977 603 302
VINYOLS-CAMBRILS\_MAUJA · Camí de ReusW, 1. +34 933 774 050

### TERUEL

TERUEL\_GARGÓN · Polígono La Paz, Parcela 143-149. +34 978 609 661 +34 978 607 980

### TOLEDO

TOLEDO\_PORCELANOSA · Pol. Ind. Sta. María de Benquerencia, Calle del Río Marchés, 123. +34 925 232 402 +34 925 232 406

### VALENCIA

ALBUIXECH\_PORCELANOSA · Avda. del Mediterráneo, Parcela 6. Pol. industrial del Mediterráneo. +34 961 417 227 +34 961 402 389
GANDIA\_PORCELANOSA GANDIA · Ciudad Laval, 13. +34 960 801 497
REQUENA\_PORCELANOSA REQUENA · Carmen, 6 - Bajo. +34 960 11 56 67
SEDAVÍ\_PORCELANOSA · Avda. Mediterráneo, s/n. Zona Comercial de Sedaví. +34 963 185 021 +34 963 180 094
VALENCIA\_SNC ARTESANÍA EN OBRA · Reina Doña Germana, 31 bajo. +34 963 417 740 +34 963 332 236
VALENCIA\_PORCELANOSA · Colón, 58. +34 963 530 230 +34 963 531 688

### VALLADOLID

VALLADOLID\_CANTALAPIEDRA · Carretera de Soria A-24, km 5,5. +34 983 217 010 +34 983 200 921

### VIZCAYA

AMOREBIETA\_BILBU · Barrio Boroa, s/n. +34 946 731 158 +34 946 733 265
BILBAO\_BILBU · Alameda Recalde, 39 - 41 +34 944 218 625 +34 944 218 879

### ZAMORA

BENAVENTE\_GÓNZALEZ Y GONZALEZ BERMAR S.L. · Pol. Industrial Benavente, 2. +34 980 633 484 +34 980 637 552
ZAMORA\_ESSEN · Muela Quebrada, 67. +34 980 521 779
ZAMORA\_TORO PAVIREMA, S.L. · Carretera Pozo Antiguo, Km 0.5. +34 980 690 772

### ZARAGOZA

ZARAGOZA\_PORCELANOSA · Parque Comercial Puerto Venecia, Calle Teatro Mailbrán, 43. +34 976 930 800 +34 976 930 603

### ANDORRA

PIRINEU\_PALMIR · Avda. Santa Coloma, 108. +34 376 804 020

### PORTUGAL

ALMANCIL (LOULÉ)\_DECORPRINCESA · +351 919 092 443 +351 289 395 752
AVEIRO\_ADRIAZUL-MATERIAIS DE CONSTRUÇÃO, LDA · +351 234 384 930 +351 234 483 815
BELA-MONCAO\_HEITOR CAMPOS AMOEDO, LDA
CHAVES\_FLAVIGRES, S.A. .: +351 276 341102 +351 276 341736
FUNCHAL-ILHA MADEIRA\_LUSOCERAMICA LDA · :926 430 293
LISBOA\_PORCELANOSA · +351 21 831 3020 +351 21 831 3029
LOULÉ\_FRANCISCO CONTREIRAS, MATERIAS PARA CONSTRUÇÃO LDA · +351 289 413 961 +351 289 415 182
MONÇÃO\_HEITOR CAMPOS AMOEDO LDA · +351 251652474 +351 251652446
MONTE REDONDO\_NORMACO · +351 256 373 629 +351 256 365 434
PONTA DELGADA\_FURMAT MATERIAIS DE CONSTRUÇÃO, LDA · +351 297 000 000
PORTIMAO\_NEPELI MATERIAIS DE CONSTRUÇÃO LDA · +351 968 577 194 +351 282 482 722
PORTO\_PORCELANOSA · +351 226 166 600 +351 226 161 959
VISEU ·PORCELANOSA VISEUT · +351 232 430 440 +351 232 430 449

### GIBRALTAR

GIBRALTAR\_LIFESTYLE DESING STUDIO · +35020066390

### INTERNACIONAL

### ALBANIA

TIRANA\_ALBA CERAMICA· +355 4 83 00 084 +355 4 83 00 084
TIRANA\_ALBA CERAMICA PORCELANOSA GRUPO · +355 4 22 33 817 +355 4 22 33 817

### ALEMANIA

ACHERN\_E. WERTHEIMER GMBH · +49 07841 6309 1300
ALTENSTADT AN DER WALDNAAB\_FLIESENHAUS LANG · +49 9602 63470
ALZEY\_J.N. KOEBIG GMBH · +49 6731 4880
ASCHAFFENBURG\_KALKWERKE · +49 (0) 60 213 601 62 +49 (0) 60 213 602 93
BAD SALZUFLEN\_W. LINNENBECKER GMBH · +49 (0) 5222 / 5301 221 +49 (0) 5222 / 5301 209
BADEN BADEN\_E. WERTHEIMER GMBH · +49 (0) 7221 50020 +49 (0)722117080
BAUTZEN\_FLIESEN LEHMANN GMBH · +49 (0) 3591 / 3726 32 +49 (0) 351 / 8931420
BAYREUTH\_FLIESEN EHRlich & CO. GMBH · +49 (0) 9 21 / 15 12 799-0
BERGISCH GLADBACH\_SCHMIDT-RUDERSDORF GMBH & CO · +49 (0) 2204 / 4007 0 771 +49 (0) 3320 / 854715
BERLIN\_FLIESENPARADIES GLAESKE + SEFZIG GMBH · +49 (0) 30 650 737 0 +49 (0) 30 650 737 34
BERLIN\_FLIESENPARADIES GLAESKE + SEFZIG GMBH · +49 (0) 30 565 555 90
BERLIN\_KERANA KERAMIK- UND NATURSTEINHANDEL GMBH · +49 (0)30 318683-16/-19
BERLIN\_W. LINNENBECKER GMBH & CO. KG · +49 (0) 30 / 756 888 +49 (0) 30 / 756 88 756
BONN-BUSCHDORF\_SCHMIDT-RUDERSDORF- BONN · +49 02 28 - 55 916-0
BOTTROP\_W. LINNENBECKER GMBH & CO. KG · +49 (0) 2041 / 7958 13 +49 (0) 2041 / 7958 10
BRAND-ERBISDORF\_FLIESEN THOMAS GMBH · +49 (0) 37322 18 0
BREMEN\_W. LINNENBECKER GMBH & CO. KG · +49 420252190
BURG\_WIEDEMANN INDUSTRIE UND HAUSTECHNIK GMBH · +49 39163103513
BURGKUNSTADT\_FLIESEN GALERIE 2,0 GMBH & CO. KG · +49 9572 386989
BURGSTÄDT\_FLIESEN THOMAS GMBH · +49 (0) 3724 / 1856 0 +49 (0) 3724 / 1856 70
DORTMUND\_W. LINNENBECKER GMBH & CO. KG · +49 (0) 231 / 562 090 22 +49 (0) 231 / 562 090 88
DRESDEN\_ECLECTIC DESIGN · +49 351 26440630
DÜSSELDORF\_SCHMIDT RUDERSDORF DÜSSELDORF · +49 (0) 211 6350112
DÜSSELDORF\_SCHMIDT RUDERSDORF VIERSEN · +49 (0) 2162 816360
EISENACH\_FLIESENZENTRUM GMBH ERFURT · +49 (0) 3691 882175
EISENBERG\_J.N. KOEBIG GMBH · +49 6351 1450
EISINGEN\_FLIESENWELT EISINGEN GMBH · +49 (0) 9353 98 46 357 +49 (0) 9353 98 46 359
ELTERLEIN\_MIRKO GLEISS · +49 (0) 37349 / 7305 +49 (0) 37349 / 6093
ERFURT\_FLIESENZENTRUM GMBH ERFURT · +49 3614270720
ERKRATH\_W. LINNENBECKER GMBH · +49 (0) 211 / 92503 19 +49 (0) 211 / 92503 34
FREIBURG\_GÖTZ & MORIZ GMBH · +49 (0) 76 145 180 +49 (0) 76 145 711 2
FULDA\_OSWALD FLIESEN UND SERVICE GMBH & CO KG · +49 (0) 66 194 151 0 +49 (0) 66 194 151 40
GERA\_BAUSTOFFE GEBR.LÖFFLER GMBH · +49 (0) 365 430 701 9 +49 (0) 365 430 701 4
GERA\_FLIESEN THOMAS GMBH · +49 (0) 365 552853-0
GÖRLITZ\_FLIESEN-PEDERSEN GMBH · +49 (0) 3581 / 402809 +49 (0) 3581 / 409166
GOTHA\_FLIESENZENTRUM GMBH ERFURT · +49 (0) 3621 5144880
GÖTTINGEN\_F+B FLIESEN UND BAUSTOFF MARKT · +49 551 998710
GREIZ\_BAUSTOFFE GEBR.LÖFFLER GMBH · +49 36 61 / 70 50-0
HAMBURG - LURUP\_CROONEN FLIESENHANDEL GMBH · +49 (0) 40 / 83383 377 +49 (0) 40 / 83383 301
HANNOVER\_W. LINNENBECKER GMBH & CO. KG · +49 (0) 511 / 438 900
HEIDENAU\_FLIESEN EHRlich & CO. GMBH · +49 (0) 35 29/ 52 85-0
HOF\_FLIESEN THOMAS GMBH · +49 (0) 9281 86005-0
HUNGEN\_MÜHL 24 · +34 (0) 6402 5200-0
JENA\_FLIESENZENTRUM GMBH ERFURT · +49 (0) 3641 - 53257-0
KARLSRUHE\_FLIESENFORUM KARLSRUHE GMBH · +49 (0) 721663035716
KIEL\_HEINRICH'S FLIESENMARKT GMBH · +49 (0) 431537340 +49 (0) 431529141
KOBLENZ\_J. N. KÖBIG GMBH KOBLENZ · +49 (0) 26 198 169 20 +49 (0) 26 198 169 10
KÖLN\_PORCELANOSA · +49 (0) 221 276 42616
KRANICHFELD\_MÜHL 24 KRANICHFELD · +49 (0) 36 450 330 +49 (0) 36 450 332 89
LAUF A. D. PEGNITZ\_FLIESEN EHRlich & CO. GMBH · +49 (0) 91 23/ 97-11-0
LEIPZIG\_FLIESEN THOMAS GMBH · +49 (0) 341 308558-0
LEIPZIG\_GRAMER GMBH · +49 341 2346430
LEVERKUSEN\_SCHMIDT-RUDERSDORF- LEVERKUSEN +49 02 14 - 8 68 13 0 +49 02 14 - 8 68 13 13
LÖBNITZ\_SACHSENKERAM GBR · +49 (0) 34208 / 7400 +49 (0) 34208 / 7400
LÖRRACH\_GÖTZ & MORIZ GMBH · +49 7621 4007100
LÜBECK\_HEINRICH'S FLIESENMARKT GMBH · +49 (0) 451896669 +49 (0) 4518973494
MAINZ\_J. N. KÖBIG GMBH MAINZ · +49 061 316 943 10 +49 061 316 942 75
MAINZ\_J.N. KOEBIG GMBH · +49 6131694328
MANNHEIM-NEUHERMSHEIM\_GRES SPANIENFLIESEN GMBH · +49 621 8799380
MESCHEDI\_W. LINNENBECKER GMBH & CO. KG · +49 (0) 291 / 952 82 21 +49 (0) 291 / 952 82 82
MÜNCHEN\_CERAMICAS OHG · +49 (0) 89 318 280 0 +49 (0) 89 318 280 20
MÜNSTER\_W. LINNENBECKER GMBH & CO. KG · +49 (0) 251 / 979 12 21 +49 (0) 251 / 979 1220
NÜRNBERG/HAFEN\_HEINRICH CHRIST GMBH & CO. KG · +49 (0) 91 164 318 0 +49 (0) 91 164 318 50
OFFENBURG\_MAIER + KAUFMANN GMBH · +49 (0) 78196780 +49 (0)781967890
POTSDAM\_KERANA KERAMIK- UND NATURSTEINHANDEL GMBH · +49 (0) 33208 547-0 +49 (0) 03381 7304501
PULHEIM\_SCHMIDT RUDERSDORF PULHEIM · +49 (0) 2238 839790
RADEBEUL\_FLIESEN EHRlich & CO. GMBH · +49 (0) 351 / 89314 10 +49 (0) 351 / 89314 20
SEALFELD\_FLIESENZENTRUM GMBH ERFURT · +49 (0) 3671 52800
SCHRAMBERG-SULGEN\_ARMBRUSTER GMBH · +49 (0) 7422 28008-0 +49 (0) 7422 28008-20
SCHRIESHEIM\_FLIESEN GALERIE SENGEWITZ · +49 6203 955330 +49 6203 955 33 29
SCHWARZENBERG\_FLIESEN THOMAS GMBH · +49 (0) 3774 13930 30
SPEYER\_SCHULTZ BAUZENTRUM GMBH & CO. KG · +49 6232/ 64620 +49 6232/ 646250
STEINACH\_MAIER + KAUFMANN GMBH · +49 (0)7832 - 796 0
TRIER\_SCHOLTES HANDELS GMBH · +49 651 9186611
UNTERGRUPPENBACH\_KONZ & SCHAEFER HANDEL GMBH · +49 (0) 71312037480 +49 (0) 71312037489
VÖLKLINGEN\_NIEDERER GMBH +49 (0) 68 989 802 21 +49 (0) 68 989 802 30

## TIENDAS / SHOWROOMS

### INTERNATIONAL

WAIBLINGEN\_KONZ GMBH · +49 (0) 7151149200 +49 (0) 710510149-209
WÜRSELEN\_SCHMIDT-RUDERSDORF- WÜRSELEN · +49 (0) 24 05 - 41 38 50 +49 (0) 24 05 - 41 38 55
ZWETHAU\_GRAMER GMBH · +49 (0) 3421 / 7327 18 +49 (0) 3421 / 7326 73

### ANGOLA

LUANDA\_PORCELANOSA ANGOLA · +244 928463705 +244 222372374

### ARABIA SAUDÍ

DAMMAM\_MANART AL ANDALOS EST · (+)966 12 6768441
DAMMAM\_MOHAMMED M. AL DOSSARY STORES · (+)966 38 348681 (+)966 38 340086
HAFUF\_MANART AL ANDALOS EST · (+) 966 11 8102824
JEDDAH\_MANART AL ANDALOS EST · (+)966 12 6768443 (+)966 12 6768440
JEDDAH\_MOHAMMED M. AL DOSSARY STORES · (+)966 12 6883446 (+)966 12 6697560
RIYADH\_MANART AL ANDALOS EST · (+)966 11 8102512
RIYADH\_MANART AL ANDALOS EST · (+)966 11 4568383
RIYADH\_MOHAMMED M. AL DOSSARY STORES · (+)966 11 4884006

### ARGELIA

ALGER\_NOVACASA · +213 21 55 07 37 +213 23 94 74 46
ORAN\_PORCELANOSA ORAN - 14237002361

### ARGENTINA

BARRACAS\_BLAISTEN S.A. · +54 11 463 620 00 +54 11 463 614 86
BUENOS AIRES\_BLAISTEN S.A. · +54 11 463 620 00 +54 11 463 614 86
BUENOS AIRES\_SHOWROOM PORCELANOSA VENIS · +54 11 4776 3008 +54 11 4776 3008
CASTELAR\_BLAISTEN S.A. · +54 11 463 620 00 +54 11 463 614 86
MARTÍNEZ\_BLAISTEN S.A. · +54 11 463 620 00 +54 11 463 614 86
MENDOZA\_VÍCTOR GULLO. · +54 261 431 4200
PILAR\_BLAISTEN S.A. · +54 11 463 620 00 +54 11 463 614 86
SAN JUSTO\_BLAISTEN S.A. · +54 11 463 620 00 +54 11 463 614 86

### ARMENIA

YEREVAN\_SACO & ARARAT-SALON BOMOND · +37 410 55 08 99 +37 410 50 05 50

### ARUBA

ORNAJESTAAD\_BANJOLUX · +297 588 0565

### AUSTRALIA

BRISBANE\_EARP BROTHERS · +61 7 3088 8999
HOBART\_ROSSETTO TILING · +61 3 6231 2931
LAUNCESTON\_ROSSETTO TILING · +61 3 6326 4955
MELBOURNE\_EARP BROTHERS · +61 3 9328 9588
NEWCASTLE\_EARP BROS TILE - NEWCASTLE · +61 2 4962 5500
OSBORNE PARK\_CERAMO · +61 8 9445 1777 +61 8 9446 3127
SYDNEY\_EARP BROTHERS · +61 2 9410 3222

### AUSTRIA

ANSFELDEN\_BEINKOFER · +43 (0) 7229 78525 +43 (0) 7229 88818 - 50
BRUCK/MUR\_TENNE BRUCK · +43 3862 588 44 +43 3862 588 44-22
GRAZ\_FLIESEN TENNE · +43 316



#### BÉLGICA

BEKKEVOORT\_GEDIMAT HENDRICKX · +32 13 15 58
DIKSMUIDE\_NV BOUWMATERIALEN G · +32 (0)51 50 00 67
GEEL\_GAVRA CERAMICS & SURFACES · +32 14 58 92 62
HEIST-OP-DEN-BERG\_PGB CERAMICA NV · +32 (0)15 253366 +32 (0)15 253367
LOMMEL\_VANGENEUGDEN VTK · +32 11 55 33 11 +32 11 55 33 22
MAASMECHELEN\_4D TEGELS · +32 89 76 44 26
MERELBEKE\_TEGELBEDRIJF DE GANCK · +32 92 30 57 30
WEVELGEM\_TEGELS DEPAEPE · +32 56 43 27 43

#### BERMUDAS

PEMBROKE\_PEMBROKE TILE & STONE CO. LTD · +441 292 8453 +441 295 8453

#### BIELORRUSIA

MINSK\_SAN REMO · +37 17 388 06 66

#### BOLIVIA

SANTA CRUZ DE LA SIERRA\_TAGOMAGO · +591 776 748 25

#### BOSNIA-HERZEGOVINA

BIJELJINA\_LUK D.O.O. · +387 55 228 100 +387 55 228 101
CITLUK\_BROTIS D.O.O. · +387 36 650 960 +387 36 650 950
SARAJEVO\_LUK D.O.O. · +387 33 777 888 +387 33 777 889

#### BRASIL

CURITIBA\_PORCEBRAS · +55 (41) 3392 1500 +55 (41) 3392 1400

#### BULGARIA

BURGAS\_ELE CERAMICA · +359 56 842 849
SOFIA\_ELE CERAMICA · +359 28 606 060
VARNA\_ELE CERAMICA · +359 52 500 555

#### BURKINA FASO

OUAGADOUGOU\_GROUPE HAGE · +226 25 30 68 28

#### CANADÁ

BRAMPTON\_PORCELANOSA EAST CANADA · 9.054.541.053 9.054.541.055
CALGARY\_PORCELANOSA CALGARY · (587) 349-2290
TORONTO\_PORCELANOSA TORONTO · 9054541053
VANCOUVER\_FONTILE DISTRIBUTORS · +604 683 9358 +604 683 6758

#### CHILE

SANTIAGO\_PORCELANOSA CHILE · (56 2) 2 434 92 87

#### CHINA

BEIJING\_GUANGZHOU PO YICK DECORATION DESIGN CO LTD (BEIJING BRANCH) · +86 1085271313 +86 8610642229976
CHANGCHUN\_CHANGCHUN PORCELANOSA CERAMIC SHOWROOM · +86 43182787172 +86 43182775881
CHONGQING\_YAOSENG BUILDING MATERIAL BUSINESS DEPARTMENT NEW NORTH ZONE · +86 23 86358360 +86 23 8635782
DALIAN\_DALIAN GREAT WORLD FURNITURE PLAZA LUBAO BLDG. MAT. BUSINESS DEP · +86 41182301911 +86 41182301911
FUZHOU\_PO YICK CERAMIC SHOWROOM JINAN DISTRICT FUZHOU · +86 59188055823 +86 59188055823
GUANGZHOU\_GUANGZHOU PO YICK DECORATION DESIGN CO LTD · +86 2022008228 +86 2022008228
GUANGZHOU\_PO YICK DECORATION DESIGN CO LTD · +86 2087018223 +86 2087018226
HANGZHOU\_DA DOU BUILDING MATERIAL BUSINESS · +86 13958149905
HEFEI\_AN HUI JIA ZHUO BUILDING MATERIALS CO LTD · +86 55164842686
JIANGYIN\_NANJING XINGLANG BUILDING MATERIAL CO LTD · +86 51081693999 +86 51081693999
JIAXING\_JIA XING FEI FAN BUILDING MATERIALS CO LTD · +86 57382770662 +86 57382770662
JIN HUA\_JIAJIAHONG BUILDING MATERIALS BUSINESS DEPARTMENT JIN DONG DISTRICT JIN HUA CITY · +8657983189988
NINGBO\_NINGBO JING ZHOU NIN DONG TUO BI MATERIAL BUSINESS DEPARTMENT · +86 57487867539 +86 57487867539
QINGDAO\_QINGDAO TOLI SPACE BUILDING MATERIALS CO LTD · +86 532 80995657 +86 532 80995657
SHANGHAI\_GUANGZHOU PO YICK DECORATION DESIGN CO LTD (SHANGHAI BRANCH) · +86 2164411484 +86 2164281607
SHANGHAI\_PORCELANOSA SHANGHAI · +86 21 61397952
SHENYANG\_SHENYANG PORCELANOSA CERAMIC SHOWROOM · +86 2431223766 +86 2485637137
SHENZHEN\_SHENZHEN PORCELANOSA PO YICK BUILDING MATERIALS CO LTD · +86 75582407728 +86 75582407738
TAIYUAN\_TAIYUAN PORCELANOSA CERAMIC SHOWROOM · +86 13701067286
TAIZHOU\_TAI ZHOU SHI MING DIAN BUIDLING MATERIALS TRADING COMPANY LTD · +86 57689807883
TANGSHAN\_TANG SHAN PORCELANOSA CERAMIC SHOWROOM · +86 3152732085
TIANJIN\_TIANJIN OULINHUI BUILDING MATERIALS CO LTD · +86 22 23528765 +86 22 88277023
WUHAN\_WUHAN HENG HUI BUILDING MATERIAL CO LTD · +86 2783995277 +86 2783995277
XIAN\_PORCELANOSA BUILDING MATERIAL BUSINESS DEPARTMENT ETDZ XIAN · +86 2986122404 +86 2986122404

#### CHIPRE

GIRNE\_MEPAS LTD · 9039 2815 2964 9039 2815 5651
LARNACA\_CYKINGS CERAMICS · +357 9937 2121 +357 2481 8128
LIMASSOL\_THE ENGINEERING AND COMMERCIAL ENTERPRISE (EKA) · +357 2585 4444 +357 2585 4445

#### COLOMBIA

BOGOTÁ\_PORCELANOSA BOGOTÁ · +57 743 0209
MEDELLÍN\_PORCELANOSA MEDELLÍN · +57(4) 322 5297

#### COREA DEL SUR

BUSAN\_COTTO CERAMIC CO LTD · 82512080022 82512088558
SEO-GU\_COTTO CERAMIC CO LTD · 82325840770 82325840660
SEOUL\_BARRO CERAMIC · 82234438600 82234438822

#### COSTA DE MARFIL

ABIDJAN\_FADCO COMPANY · +225 21757355 +225 21757358

#### COSTA RICA

SAN JOSÉ\_FERNANDEZ AGUILAR S.A. · +506 222 5674 +506 221 9952

#### CROACIA

POREC\_SPINA · +385 52 451 348 +385 52 434 005
PULA\_SPINA · +385 52 219 002 +385 52 219 118
RIJEKA\_SPINA · +385 51 741 300 +385 51 741 298
SPLIT\_SPINA · +385 21 668 991 +385 21 668 992
VARAZDIN\_SPINA · +385 42 303 707 +385 42 303 709
ZAGREB\_ABC INTERIJER · +385 16 393 164 +385 16 055 985
ZAGREB\_SPINA · +385 13 492 552 +385 13 492 560

#### DINAMARCA

AARHUS\_DOKK16 A/S · +45 31 12 00 99
GLOSTRUP\_MOSAIKHJORNET · +45 43 633 900 +45 43 663 857

#### ECUADOR

CUENCA\_GRIFINE HOME CENTER S.A · (593) 07 281-8089
GUAYAQUIL\_GRIFINE HOME CENTER S.A · (593)4 370-2830
QUITO\_GRIFINE HOME CENTER S.A · (593) 2 393-1920

#### EE.UU.

801 E EXPY 83\_GILSA NORTH AMERICA · +1 956 223 2900
ANAHEIM\_PORCELANOSA ANAHEIM · +1 714 772 3183 +1 714 772 9851
ATLANTA\_PORCELANOSA ATLANTA · +1 404 973 0640
BOSTON\_PORCELANOSA BOSTON - BOSTON DESIGN CENTER · +1617 963 7666 +1 617 963 7675
BROOKLYN\_PORCELANOSA BROOKLYN · +1 929 239 3260
CHESNUT HILL\_PORCELANOSA CHESNUT HILL · +1 617 963 7666
CHICAGO\_PORCELANOSA CHICAGO · +1312 204 6220 +1 312 204 6240
DALLAS\_PORCELANOSA DALLAS · +1214 377 2327 +1 214 234 1340
DENVER\_PORCELANOSA DENVER · +1 303 802 3210
EAST BRUNSWICK\_PORCELANOSA EAST BRUNSWICK · +1 732 613 1915 +1 732 613 9181
GLENDALE\_GLENDALE TILE · +1 818 500 8505
HERMOSA BEACH\_AMIRIAN HOME · +1 281 605 2770
HOUSTON\_PORCELANOSA HOUSTON · +1 424 390 4460
KING OF PRUSSIA\_PORCELANOSA KING OF PRUSSIA · +14 847 510 050 +14 847 510 047
MIAMI\_PORCELANOSA MIAMI · +1 305 715 7153 +1305 592 6999
MIAMI\_PORCELANOSA MIAMI DESIGN DISTRICT · +1 786 329 6753
NEW YORK CITY\_PORCELANOSA MANHATTAN FLAGSHIP STORE · +16 467 511 180
NORTH BETHESDA\_PORCELANOSA ROCKVILLE · +1240 290 1120 +1 240 290 1125
PARAMUS\_PORCELANOSA PARAMUS · +1 201 712 0556 +1 201 712 0744
POMPANO BEACH\_PORCELANOSA POMPANO BEACH · +1 954 968 7666 +1 954 968 7669
RAMSEY\_PORCELANOSA RAMSEY · +1 201 995 1310 +1 866 841 5185
RIVERSIDE\_PORCELANOSA RIVERSIDE · +1 203 698 7618 +1 203 698 7619
SAN DIEGO\_PORCELANOSA SAN DIEGO · +1 858 322 6012
SAN FRANCISCO\_PORCELANOSA SAN FRANCISCO · +1 415 593 7763 +1 415 593 7864
SAN JOSÉ\_PORCELANOSA SAN JOSE · +1 408 467 9400 +1 408 467 9410
SEATTLE\_PORCELANOSA SEATTLE · +2 066 738 395 +2 066 738 402
WALNUT CREEK\_PORCELANOSA WALNUT CREEK · +1 925 952 7430
WASHINGTON DC\_PORCELANOSA WASHINGTON DC · +1 022 041 6555
WEST HOLLYWOOD\_PORCELANOSA WEST HOLLYWOOD · +1 310 300 2090
WESTBURY\_PORCELANOSA WESTBURY · +1 516 338 0097 +1 516 338 0098

#### EGIPTO

EL CAIRO\_MAHGOUB TRADING & IMPORTING · +20 2 57 12 565 +20 2 57 39 344

#### EMIRATOS ÁRABES

DUBAI\_PORCELANOSA ASSOCIATE DUBAI -(+ 971) 43 35 38 88

#### ESLOVAQUIA

BRATISLAVA\_CERSA · 42124442833
KOSICE\_VODOARM · (055) 6222660 (055) 6222654

#### ESLOVENIA

CELJE\_CHIC INTERIER CELJE · 386 3 491 33 21
LJUBLJANA\_ŠMARTINSKA CESTA 52 · 38670579223

#### ESTONIA

TALLINN\_PLAADIPUNKT · +372 650 0720 +372 650 0723

#### FEDERACIÓN RUSA

ANAPA\_CASA AQUA · +7 (918) 996 33 11
BARNAUL\_PORCELANOSA BARNAUL · +7 (3852) 59 10 69
EKATERINBURG\_BOMOND · +7 (343) 287 55 79
GELENDZHIK\_ELEMENT DESIGN CENTER · +7 (86141) 30 400 +7 (929) 822 28 66
GRÖZNY\_BOMOND · +7 (8712) 22 45 28
KAZAN\_ARTDECORIUM · +8 917 917 23 22
KHABAROVSK\_DOM APEX · (4232) 30 06 88
KHIMKI\_ZODIAC · +7 (495) 730 97 97
KRASNODAR\_BOMOND · +7 (861) 210 26 83
KRASNOYARSK\_ELITSTROY · +7 (391) 206 99 99
MAKHACHKALA\_T. D. MODERN · +7 (8722) 676 569

MOSCOW\_ARTISAN · +7 (495) 742 40 40
MOSCOW\_INTERIOR SALON №1 · +7 (495) 956 77 66
MOSCOW\_MASTERDOM · +8 499 120-00-77
MOSCOW\_ZODIAC · +7 (495) 730 97 97
MYTISCHI\_ZODIAC · +7 (495) 730 97 97
NIZHNY NOVGOROD\_ZODIAC · +7 831 216 08 08
NOVOROSIYSK\_AGORA · +7 800 234-39-00
NOVOSIBIRSK\_MOY DOM · +7 (383) 2396508
PYATIGORSK BOMOND · +7 (8793) 97 55 44
ROSTOV NA DONU\_BOMOND · +7 (863) 302 02 18
RYAZAN\_CINTI · +7 (4912) 46 00 46
SAMARA\_ZODIAC · +7 (495) 29 21 464
SOCHI\_SALON BOMOND · 1314
ST. PETERSBURG\_SALON ELITNOY KERAMIKI NOVUS · +7 (812) 325 12 45
ST. PETERSBURG\_ZODIAC · +7 812 643 44 12
ST. PETERSBURG\_ZODIAC · +7 495 730 9797
STAVROPOL\_SALON VALENCIA · +7 (8652) 298 151
SURGUT\_ARKHITEKTURNYI DECOR · +8 (3462) 940 040
TYUMEN\_GALLA · +7 345 251 62 07
VLADIVOSTOK\_DOM APEX · +7 (4232) 300 688
VLADIVOSTOK\_DOM APEX · +7 (8652) 298 151
VOLGOGRAD\_BOMOND · +7 (8442)94-47-36

#### FILIPINAS

CEBU\_CASA EUROPA · +63 2 519 3515
MANILA\_CASA EUROPA INC. · +63 32 272 8180

#### FINLANDIA

HÄMEENLINNA\_LAATTAPISTE · +358 (0)207 414 770
HYVINKÄÄ\_LAATTAPISTE · +358 (019) 455 830
JOENSUU\_LAATTAPISTE · +358 (0)207 880 880
JYVÄSKYLÄ\_LAATTAPISTE · +358 (0)207 433 830
KOUVOLA\_LAATTAPISTE · +358 (0)207 880 760
KUOPIO\_LAATTAPISTE · +358 (0)17 266 3500
LAHTI\_LAATTAPISTE · +358 (03) 875 950
LAPPEENRANTA\_LAATTAPISTE · +358 (0)207 880 720
OULU\_LAATTAPISTE · +358 (0)20 7880 780
PORI\_LAATTAPISTE · +358 (0)207 288 320
RAISIO\_LAATTAPISTE · +358 (0)207 288 300
ROVANIEMI\_LAATTAPISTE · +358 (016) 310 403
TAMPERE\_LAATTAPISTE · +358 (03) 3142 3300
VAASA\_LAATTAPISTE · +358 (0)207 880 740
VANTAA\_LAATTAPISTE · +358 9 878031

#### FRANCIA

AJACCIO\_ART ET STYLES · +33 (0)495 221 999 +33 (0)495 231 547
ANNECY\_MAGASIN BULLES ET EAU · 456349719
ARCUEIL\_PORCELANOSA PORTE D'ORLÉANS · +33 (0)149 121 257 +33 (0)149 121 258
AUBAGNE\_PORCELANOSA MARSEILLE · +33 (0)442 624 330 +33 (0)442 624 339
AUGNY\_PORCELANOSA METZ · 03 72 72 97 40 03 72 72 97 42
BEAUCOUZÉ\_PORCELANOSA ANGERS · +33 (0)241 738 100 +33 (0)241 733 721
BESANÇON\_PORCELANOSA BESANÇON · +33 (0)381 416 363 +33 (0)381 416 369
BIGUGLIA\_ART ET STYLES · +33 (0)495 589 898 +33 (0)495 305 318
BOULAZAC\_PORCELANOSA PÉRIGUEUX · 05 53 46 33 98
BREST\_PORCELANOSA BREST · +33 (0)298 025 100 +33 (0)298 415 401
CABESTANY\_PORCELANOSA PERPIGNAN · 04 68 29 76 20
CHAMBRAY LES TOURS\_PORCELANOSA TOURS · +33 (0)247 808 787 +33 (0)247 808 789
CHAMPAGNE-AU-MONT-D'OR\_DÉPÔT LYON · 04 78 66 81 56
CHAMPAGNE-AU-MONT-D'OR\_PORCELANOSA LYON · +33 (0)478 668 151 +33 (0)478 432 003
CHASSENEUIL DU POITOU\_PORCELANOSA POITIERS · +33 (0)549 119 787 +33 (0)549 119 788
CHENÔVE\_PORCELANOSA DIJON · +33 (0)380 588 701 +33 (0)380 588 595
COIGNIÈRES\_PORCELANOSA COIGNIÈRES · +33 (0)130 491280 +33 (0)130 491328
FLEURY LES AUBRAIS\_MILESPACES · 02 38 42 15 38
GUÉRANDÉ\_PORCELANOSA LA BAULE · +33 (0)240 607 273 +33 (0)240 110 659
LA CHAPELLE SAINT AUBIN\_PORCELANOSA LE MANS · +33 (0)243 236 520 +33 (0)243 240 512
LA ROCHE SUR YON\_PORCELANOSA LA ROCHE-SUR-YON · +33 (0)251 241 217 +33 (0)251 242 399
LA TESTE DE BUCH\_SOLS ET BAINS DE LA DUNE · 05 57 156 442
LE HAVRE\_PORCELANOSA LE HAVRE · +33 02 35 54 21 30 +33 02 35 41 41 22
LES CLAYES SOUS BOIS\_PORTICO DESIGN · 01 30 44 13 54 01 30 44 13 54
LEZENNES\_PORCELANOSA LILLE · +33 (0)320 340 340 +33 (0)320 340 341
LORIENT\_PORCELANOSA LORIENT · +33 (0)297 875 000 +33 (0)297 370 607
MANDELIEU LA NAPOULE\_PORCELANOSA CANNES · +33 (0)493 477 360 +33 (0)493 477 402
MEAUX\_PORCELANOSA MEAUX · +33 (0)160 092828 +33 (0)160 093131
MERIGNAC\_PORCELANOSA BORDEAUX · +33 (0)556 124 848 +33 (0)556 124 849
MONDEVILLE\_PORCELANOSA CAEN · +33 (0)231 820 000 +33 (0)231 820 019
MONTIGNY-LÈS-CORMEILLES\_PORCELANOSA MONTIGNY · +33 (0)1 39 31 19 79 +33 (0)1 39 31 14 92
NICE\_PORCELANOSA NICE · +33 (0)493 041 963
NÎMES\_PORCELANOSA NÎMES · +33 (0)466 282 780 +33 (0)466 282 781
ORVAULT\_PORCELANOSA NANTES · +33 (0)228 073 950 +33 (0)228 073 957
PARIS\_PORCELANOSA PARIS 7ÈME · 01 42 84 84 00 01 42 84 84 01
PÉROLS\_PORCELANOSA MONTPELLIER · +33 (0)467 503 600 +33 (0)467 501 121
RANTIGNY\_J-10 · +33 344 282 874
SAINT GRÉGOIRE - RENNES\_PORCELANOSA RENNES · +33 (0)223 200 808 +33 (0)299 369 688
SAINT HERBLAIN\_DÉPÔT SAINT-HERBLAIN · +33 2 40 16 94 00 +33 2 40 16 94 14

SAINT MAUR\_SARL CARRELAGE PRO · +33 0 254 086 684
SAINT-ETIENNE\_PORCELANOSA ASSOCIATE · 04 77 30 56 76
SAINT-PÉRAY\_PORCELANOSA ASSOCIATE · +33 (0)4 75 60 53 51 +33 04 75 80 22 40
TIGERY\_DÉPÔT PARIS IDF · 01 69 90 49 00
TOULOUSE\_PORCELANOSA TOULOUSE · 05 34 56 57 60 05 34 56 57 86
TOURVILLE LA RIVIÈRE\_PORCELANOSA ROUEN · +33 (0)235 650 655 +33 (0)235 650 656
VANNES\_PORCELANOSA VANNES · +33 (0)297 460 292 +33 (0)297 461 210
VANNES LÈS MÂCON\_HENRI DE ALMEIDA CREATIONS · +33 03 85 36 33 15 +33 03 85 30 53 64
VEDÈNE\_PORCELANOSA AVIGNON · 04 90 02 64 02
VENDENHEIM\_PORCELANOSA STRASBOURG · +33 03 88 20 82 90 +33 (0)388 209 107
VERT SAINT DENIS\_PORCELANOSA MELUN · +33 (0)160 565 747 +33 (0)160 569 080
WITTENHEIM\_PORCELANOSA MULHOUSE · +33 (0)389 570 260 +33 (0)389 570 261

#### GEORGIA

TBILISI\_LUXOR SHOP · +995 32 23888898 +995 32 2388399

#### GHANA

ACCRA\_CASA TRASACCO · +233 30 282 3322

#### GRECIA

ATTICA\_SUERO · +30 2105 594 520 +30 2105 594 521
GLIFADA\_HATZ GROUP · +30 2310 753 564
THESSALONIKI\_PORCELANO · +30 2310 753 003 +30 2310 753 003
THESSALONIKI\_PORCELANO · +30 2310 474 767 +30 2310 474 403
THESSALONIKI\_PORCELANO · +30 2310 700 861 +30 2310 700 861

#### GUADALUPE

BAIE MAHAULT\_GUADELOUPE CERAMIQUE · +590 266 261 +590 266 412
SAINT BARTHELEMY\_ALMA QUINCAILLERIE · +590 276 494 +590 276 738

#### HAÍTI

PORT AU PRINCE\_EUROCERAM · 0 999 999 984

#### HONG KONG

KOWLOON\_TAI YICK BUILDING MATERIALS · +852 23 956 670 +852 23 957 831

#### HUNGRÍA

BÉKÉSCSABA\_PALATINUS FURDOSZOBASZALONOK · +36 66 328 432 +36 66 328 432
BUDAPEST\_MIRAGE 86 ZRT. · +36 1 793 9532 +36 1 799 6289
BUDAPEST\_PALATINUS FURDOSZOBASZALONOK · +36 1 430 04 17 +36 1 387 91 36
DREBECEN\_PALATINUS FURDOSZOBASZALONOK · +36 3 031 94 353 +36 52 536 822
EGER\_PALATINUS FÜRDŐSZOBASZALON EGER · +36 3681 4319 +36 3631 0575
EGER\_PALATINUS FURDOSZOBASZALONOK · +36 0636 312 013 +36 0636 313 270
ÉRD M7-ES FELJÁRÓ\_VS FÜRDŐSZOBA ÉRD · +36 304 831 154
GYÖNGYÖS\_PALATINUS FURDOSZOBASZALONOK · +36 37 500 162 +36 37 500 163
KECSKEMÉT\_PALATINUS FÜRDŐSZOBASZALON KECSKEMÉT · +367607918
MAGYAR\_VS RBC - RAVAK BUSINESS CENTER · +36 304831154
MISKOLC\_PALATINUS FURDOSZOBASZALONOK · +36 46 412 741 +36 46 416 256
NYÍREGYHÁZA\_KOVÁCS TÚZÉP CT . VIDA ERZSÉBETCCC · +36 42 598 073
TARJÁN\_STRAUBINGER ÉPÍTÉSI VÁLLALKOZÓ KFT. · +36 303 483 773

#### INDIA

NEW DELHI\_MARMO HOME PVT. LTD. · +91 11 47128800 +91 11 23218728

#### INDONESIA

BANDUNG\_WISMA SEHATI (BANDUNG) · +62 22 723 8515 +62 22 723 8516
JAKARTA\_WISMA SEHATI (BSD) · +62 21 537 7278 +62 21 537 7880
JAKARTA\_WISMA SEHATI (MANGGA DUA) · +62 21 6013303 +62 21 6251221
JAKARTA\_WISMA SEHATI (POLIM) · +62 21 72787711
SEMARANG\_WISMA SEHATI (SEMARANG) · +62 24 356 2233 +62 24 356 2222
SURABAYA\_WISMA SEHATI · +62 31 5631999

#### IRÁN

TEHRAN\_FARBAR COMPANY · +982188036364

#### IRAQ

BAGHDAD\_AKSESUAR GROUP · +944 772 736 00 55
ERBIL\_AKSESUAR INSAAT ERBIL · +964 750 835 0055 +964 66 210 1900

#### IRLANDA

CORK\_O.B. HEATING, PLUMBING, BATHROOMS & TILES · +353 0 214 310 000 +353 0 214 310 003
DUBLIN\_TILESTYLE LTD · +00 353 1 8555200 +00 353 1 8557471
RATHNEW\_MILLER BROS STONE DEVELOPMENT · +353 0404 32222





ROTHENBURG\_SABAG SA · +41 41 289 72 72 +41 41 289 72 73  
 SEVELEN\_KAISER AG BAD & PLÄTTLI · +41 81 785 2242 +41 81 785 2204  
 VOLKETSWIL\_MPV HANDELS AG · +41 (0)43 399 53 00 +41 (0)43 399 53 20  
 YVERDON-LES-BAINS\_SABAG SA · +41 24 423 44 30 +41 24 423 44 45  
 YVERDON LES BAINS\_SABAG YVERDONS · +41 24 423 4444

#### **SURINAM**

PARAMARIBO\_JAP HOUSING · +597 817-0064

#### **TAILANDIA**

BANGKOK\_BOONTHAVORN CERAMIC (RATCHADAPISEK) · +66 2275-0029 +66 2275-2057  
 BANGKOK\_BOONTHAVORN CERAMIC CO. LTD. (PIN-KLAO) · +66 2441-3075 +66 2441-4049  
 BANGKOK\_BOONTHAVORN CERAMIC CO. LTD. (KASET NAVAMIN) · +66 2791-2777 +66 2943-9058  
 BANGKOK\_BOONTHAVORN CERAMIC CO. LTD. (SUVARNNABHUMI) · +66 2316-0429 +66 2750 0682  
 BANGKOK\_BOONTHAVORN CERAMIC CO. LTD. (PATTAYA) · +66 38 052 222 +66 38 052 221  
 CHIANGMAI\_BOONTHAVORN CERAMIC CO. LTD. (CHIANGMAI) · +66 5310-5099 +66 5310-5107  
 MUEANG SURAT THANI DISTRICT\_BOONTHAVORN CERAMIC - SURAT THANI · +66 77 237 000  
 PATHUMTHANEE\_BOONTHAVORN CERAMIC CO. LTD. (RANGSIT) · +66 2902-0171 +66 2902-0184  
 PRACHUABKIRIKUN\_BOONTHAVORN CERAMIC CO. LTD. (HUAHIN) · +66 3252 2555 +66 5488-4144 +66 3252-0141  
 SAMUTSAKHON\_BOONTHAVORN CERAMIC - SAMUTSAKHON · +66 2 896 44712 +66 2 896 4473  
 UDON THANI\_BOONTHAVORN CERAMIC - UDON THANI · +66 42 215 678

#### **TANZANIA**

DAR ES SALAAM\_ABC EMPORIO TANZANIA · +255 719885566

#### **TÚNEZ**

GABES\_ABC ABDENNADHER · 75 29 49 10 74 24 48 85  
 HAMMAM SOUSSE\_ABC ABDENNADHER · 73 32 44 24 73 32 44 25  
 HAMMAMET\_ABC ABDENNADHER · 72 26 04 77 72 26 04 77  
 MENZEL HAYET\_ABC ABDENNADHER · 73 41 04 16 73 41 04 01  
 SFAX\_ABC ABDENNADHER · 74 46 80 72 74 24 48 85  
 SOUSSE\_ABC ABDENNADHER · 73 37 14 76 73 37 14 75  
 TUNIS\_ABC ABDENNADHER · 71 72 58 80 71 72 57 77 71 76 00 46  
 TUNIS\_LIFE STYLE · +216 71 861 551 +216 71 861 549  
 TUNIS CEDEX\_ABDENNADHER BRICOLAGE CENTER · +216 71 725 194 +216 71 760 046

#### **TURQUÍA**

ISTAMBUL\_YÜTAS · +90 2 1227 44720 +90 2 1227 20874  
 ISTAMBUL\_AKSESUAR GROUP · +90 2 1259 85599 +90 2 1259 85599  
 ISTAMBUL\_AKSESUAR İNŞAAT · +90 2 1259 85598 +90 2 1259 85599  
 ISTAMBUL\_YÜTAŞ · +90 2 1227 20874

#### **UCRANIA**

DNIPROPETROVSK\_EUROPA DNIPRO · (0562) 31 27 53  
 KHMELNYTSKYI\_SOPRANO · +380 673 543 447  
 KYIV\_SALON MILLENNIUM CONCEPT · (044) 279 60 60  
 LVIV\_KERAMA MARKET · +380 322 972 500  
 MYKOLAIV\_YALOT · +380 512 500 284  
 POLTAVA\_DOGODA · +380 532 687 575  
 TERNOPIL\_VERO · 098 67 67 112  
 VINNYTSIA\_LANA · +380 432 507 838

#### **UGANDA**

KAMPALA\_ABC STILES & BATHZ · +256 776022333

#### **URUGUAY**

MONTEVIDEO\_ACHER · +598 2 487 5630  
 PUNTA DEL ESTE\_ACHER · +598 4 224 8343 +598 42 250869

#### **UZBEKISTÁN**

TASHKENT\_PREMIUM CONCEPT · +998 71 256 29 05  
 TASHKENT\_PORCELANOSA · +998 97 753 00 65

#### **VIETNAM**

HANOI\_MILAN ARCHITECTURAL · 0913212568 0986110133  
 HANOI\_MILAN ARCHITECTURAL · +84 8 5412 1819 +84 8 5412 1820  
 HANOI\_MILAN HOME CENTER · 977800785 +84 4 3234 5028  
 HANOI\_MILAN HOME CENTER DISTRIBUIDOR MR VU THAI · +84 9 1321 2568 +84 4 3234 5028  
 HO CHI MINH CITY\_CASABELLA CO LTD · +84 9 1323 7771

#### **YEMEN**

SANAA\_AL-YAMAMAH GROUP/ABO JALAL TAHER CORPORATION FOR GENERAL TRADE · +967 1 470 375 +967 1 405 665

#### **YIBUTI**

DJIBOUTI\_AL-NEIMA IMMOBILIERE · 00253-21356659 00253-21356289

LOCALICE SU TIENDA EN NUESTRO BUSCADOR  
 FIND YOUR SHOWROOM IN OUR BROWSER

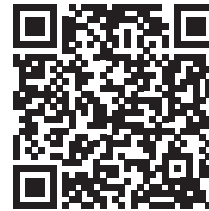

## 2020 - PL\_VI 01/2020

PORCELANOSA S.A. se reserva el derecho de modificar y/o suprimir ciertos modelos expuestos en este catálogo sin previo aviso. Los colores de las piezas pueden presentar ligeras diferencias respecto a los originales. Los ambientes se muestran en este catálogo son sugerencias decorativas de carácter publicitario debiéndose utilizar en la instalación real las instrucciones de colocación editadas por PORCELANOSA.

### 2020 PORCELANOSA

El contenido de este catálogo está protegido por la Ley de Propiedad Intelectual, Real Decreto Legislativo 1/1996. Cualquier reproducción del mismo, en parte o en su totalidad, sin autorización expresa de PORCELANOSA puede ser sancionada conforme el Código Penal.

*PORCELANOSA S.A. reserves the right to modify and/or discontinue certain models displayed in this catalogue. The colours of pieces displayed herein may differ slightly from originals. The settings shown in this catalogue are design proposals for advertising purposes. In real situations in which the tiles are laid, the installation instructions published by PORCELANOSA should be followed.*

### 2020 PORCELANOSA

*The contents of this catalogue are protected by virtue of the Spanish Intellectual Property Act, Royal Legislative Decree 1/1996. The partial or total reproduction of this catalogue, without the express authorisation of PORCELANOSA is punishable under the Spanish Criminal Code.*

## CERAMIC BOOK 2020

Diseño y fotografía: Dpto. Publicidad Porcelanosa.

Edita: PORCELANOSA S.A.

Imprime: Abacus Gráfica

*Design & Photography: Porcelanosa's Publicity Department.*

*Edition: PORCELANOSA S.A.*

*Printed by: Abacus Gráfica*





